

Name: \_\_\_\_\_

**GCSE Maths 2022**  
**Edexcel Foundation Paper 3**  
**Set A**  
**Calculator**



**Equipment**

1. A black ink ball-point pen.
2. A pencil.
3. An eraser.
4. A ruler.
5. A pair of compasses.
6. A protractor.

**Guidance**

1. Read each question carefully.
2. Check your answers seem right.
3. Always show your workings

**Information**

1. This paper has been created based on topics in the Advance Information.
2. Also see Corbettmaths for the checklist for the entire GCSE as these topics may still be useful for Paper 3
3. There is one question per topic - this paper is designed to give an opportunity to practice each topic rather than replicate the actual paper.
4. The marks for questions are shown in brackets

[GCSE 2022 Resources](#)



1. Shown below are some triangle on a centimetre grid.

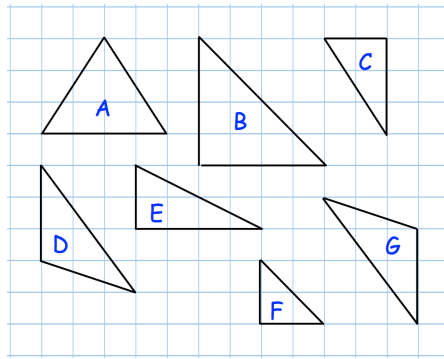

What kind of triangle is triangle A?

.....  
**(1)**

2. A quadrilateral is drawn below.  
It has two pairs of parallel sides.

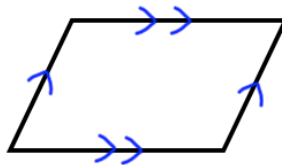

(a) Write down the name of this quadrilateral.

.....  
**(1)**

(b) How many lines of symmetry does the shape have?

.....  
**(1)**

(c) Draw a quadrilateral with two lines of symmetry

**(1)**

3.

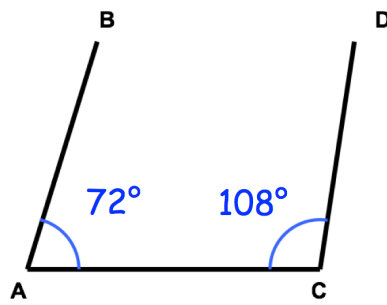

Not drawn accurately

Edward says the lines AB and CD are parallel.  
Is Edward correct?  
Explain your answer.

.....  
.....

(2)

4.

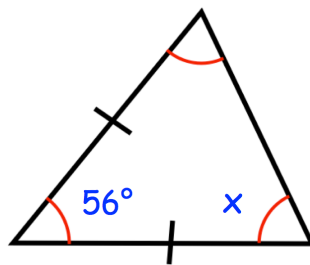

Find the size of angle x

.....<sup>o</sup>  
(2)

5. The diagram shows the position of two people, A and B, who are on their Duke of Edinburgh expedition.



The bearing of person C from person A is  $062^\circ$   
The bearing of person C from person B is  $275^\circ$

In the space above, mark the position of person C with a cross (x). Label it C.

**(3)**

6. The map below shows the position of a church and a school.

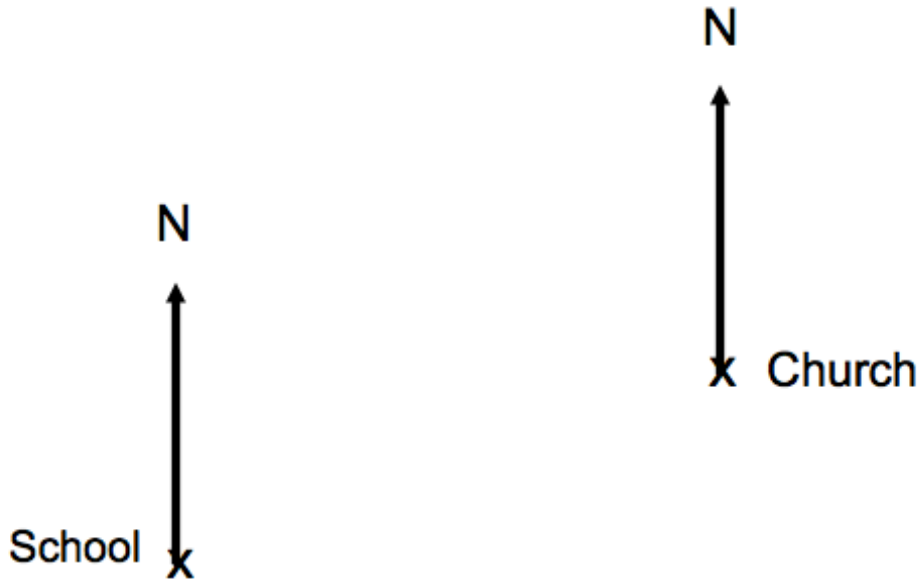

The scale of the map is 1 : 10,000

- (a) Find the actual distance between the church and school.  
Give your answer in metres.

.....m  
(2)

- (b) Find the bearing of the school from the church.

.....°  
(2)

7. Shown is the plan of a small field.

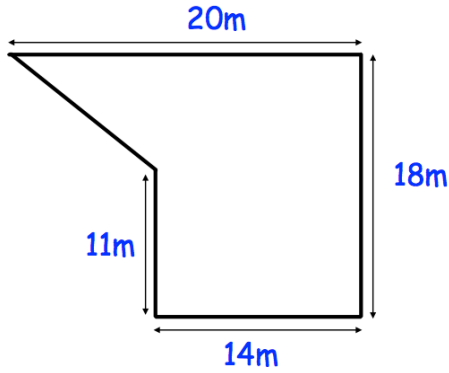

Thomas is going to keep some chickens in the field.  
Each chicken needs  $5\text{m}^2$ .

Work out the greatest number of chickens Thomas can keep in the field.

.....  
(5)

8.

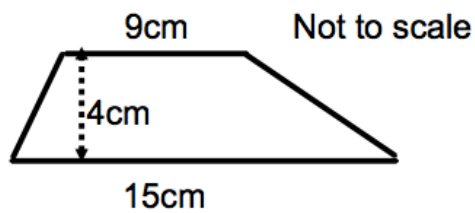

Calculate the area of the trapezium.

..... $\text{cm}^2$   
(2)

9. A car travels at 20km/h  
Write this speed in m/s

.....m/s  
**(2)**

---

10. Shown is a solid shape.

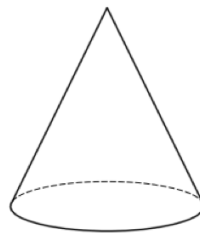

- (a) What is the mathematical name for the shape?

.....  
**(1)**

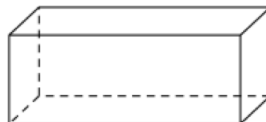

The shape above is a cuboid.

- (b) How many faces does a cuboid have?

.....  
**(1)**

- (c) How many edges does a cuboid have?

.....  
**(1)**

- (d) How many vertices does a cuboid have?

.....  
**(1)**

11. Here is a 3D shape

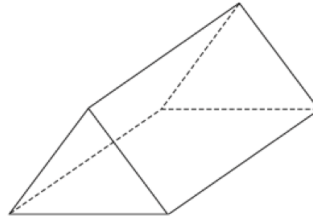

(a) Write down the name of this 3D shape.

.....  
**(1)**

(b) How many vertices does the 3D shape have?

.....  
**(1)**

---

12. Ella finishes school at 3pm.  
The time on her watch is 14:13

How long is it until Ella finishes school?

.....  
**(1)**



13. The timetable shows the times of trains from Southville to Milton.

Southville	0630	0650	0720	0745
Leek	0703	0715	0751	0810
Milton	0824	0835	0920	0940

- (a) Georgie arrives at the station at Southville at 0658 and gets the next train to Leek.

What time does this train leave Southville?

.....  
(1)

- (b) Which train completes the journey from Southville to Milton in the shortest time?

.....  
(2)

14.



A village is 20 miles from Belfast.

Conor drives from the village to Belfast at 40mph

Kelly drives from the village to Belfast at 50mph

Work out how much longer the journey takes Conor.

Give your answer in minutes.

.....minutes  
**(3)**

15. Material A has a density of  $5.8\text{g/cm}^3$ .

Material B has a density of  $4.1\text{g/cm}^3$ .

377g of Material A and 1.64kg of Material B form Material C.

Work out the density of Material C.

..... $\text{g/cm}^3$   
**(4)**

16. A box is placed on a table and exerts a force of 250N on an area of 20cm<sup>2</sup>  
Work out the pressure on the table.

.....N/cm<sup>2</sup>  
**(2)**

---

17. Below is rectangle, ABCD

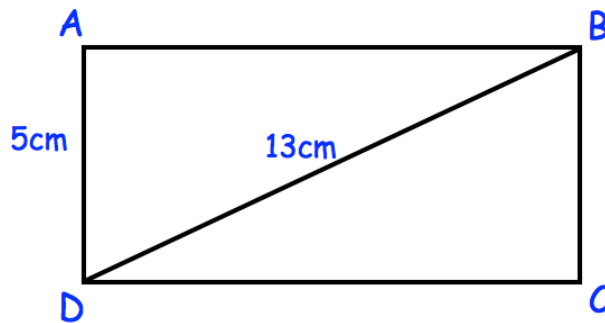

AD = 5cm  
BD = 13cm

Calculate the perimeter of rectangle ABCD

.....cm  
**(3)**

18. James bought a motor scooter on hire purchase.  
He paid a deposit of £275 and 18 monthly payments of £36.

At the end of the payments, he sold the motor scooter for £450.

How much did it cost him in total?

£.....  
**(3)**

---

19. Paul has £10 to buy rulers at 60p each.

What change should he get if he buys as many as possible?

.....  
**(3)**

---

20. Fill in the missing digits to make the addition correct.

$$\begin{array}{r} \square 6 4 \\ + 2 \square 6 \\ \hline 7 5 \square \end{array}$$

**(2)**

21.

<b>Format</b>	<b>Weight</b>	<b>1st Class</b>	<b>2nd Class</b>
<b>Letters</b>	0 - 100g	62p	53p
<b>Large Letters</b>	0 - 100g	93p	73p
	101 - 250g	£1.24	£1.17
	251 - 500g	£1.65	£1.48

The table shows the prices of first and second class stamps for Letters and Large Letters up to 500g.

Matt is going to post a Letter weighing 80g and a Large Letter weighing 300g. He chooses to post them both as second class.

How much money has Matt saved by posting second class instead of first class?

.....  
(3)

22. Round 8.4791 to 1 decimal place

.....  
(1)

23. From the list of numbers

3    5    7    9    11    15    24

(a) Write down a factor of 12

.....  
**(1)**

(b) Write down a factor of 28

.....  
**(1)**

(c) Write down a factor of 81

.....  
**(1)**

---

24. Find  $\sqrt{5.76}$

.....  
**(1)**

25. Trains leave Bristol

to Cardiff every 15 minutes  
to London every 21 minutes

A train to Cardiff and a train to London both leave Bristol at 11am.

At what time will a train to Cardiff and a train to London next leave Bristol at the same time?

.....  
**(3)**

---

26. Jamie wants to shade  $\frac{1}{3}$  of the grid.

Each square he decides to shade, he must shade in fully.

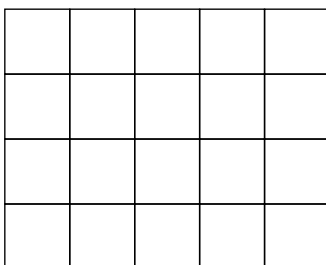

Can he successfully shade in  $\frac{1}{3}$  of the grid?

Explain your answer.

.....  
.....  
**(2)**

27. Circle the two fractions that are **not** equivalent to  $\frac{2}{3}$

$$\frac{14}{21} \quad \frac{20}{33} \quad \frac{15}{25} \quad \frac{12}{18}$$

---

(1)

28. Write 72% as a fraction.  
Give your answer in its simplest form.

.....  
(2)

29. The price of a cinema ticket is reduced from £8 to £7.50  
Calculate the reduction as a percentage of the original price.

.....%  
(3)



30. Edward and his four friends go on holiday.  
The total cost of the holiday is £3600.

Edward is going to stay longer than his friends and he is going to pay 35% of the total cost.

The rest of the total cost is to be shared equally between his four friends.

Edward says,

*“I pay twice as much money for the holiday than each of my friends.”*

Is Edward correct?  
Explain your answer.

**(4)**

31. Orla weighed 3.77kg when she was born.  
On Orla's second birthday she weighed 12.8kg.

Calculate the percentage increase in her weight.

.....%  
**(3)**

---

32. A fish tank sprung a leak and loses 20% of its water.  
There is now 240 litres of water in the fish tank.

How much water was in the fish tank before the leak?

.....l  
**(3)**

33. The number of people who voted for the Green Party in an election was 1500.  
The number of people who voted for the Blue Party was 9000.

Write the ratio of Green Party voters to Blue Party voters in the form 1:n

.....  
(2)

---

34. Ballymena Rovers started a football season on –14 points

Each win is worth 3 points.  
Each draw is worth 1 point  
Each loss is worth 0 points.

Over the season, Ballymena Rovers won 15 matches, drew 3 matches & lost 2.

How many points did they finish with at the end of the season?

.....  
(3)

35. 7 tables cost £318.50  
24 chairs cost £222

A school want to buy 270 tables and 576 chairs.

The headteacher says the total cost will be under £17500

Is the headteacher correct?

You must show your workings.

.....  
(4)

36. Calculate the value of

$$\sqrt[3]{(25.4 - 5.9)^2}$$

- (a) Write down your full calculator display.

.....  
(1)

- (b) Give your answer to three significant figures.

.....  
(1)

37. An airplane has economy and first class seating.  
There are  $s$  seats in each row in economy.  
There are  $t$  seats in each row in first class.

There are 9 rows in first class and 24 rows in economy.

Write down an expression, in terms of  $s$  and  $t$ , for the number of seats on the airplane.

.....  
(2)

---

38. (a) Simplify  $13a + 2c - 9c + 3a$

.....  
(2)

- (b) Simplify  $6a + 7w - 5a - 9w$

.....  
(2)

---

39. Simplify

(a)  $y \times 4$

.....  
(1)

(b)  $2 \times w \times 3w$

.....  
(1)

40. Here are the first four terms of a number sequence.

7      10      13      16

Work out the difference between the 10th term and 15th term in the sequence.

.....  
(2)

---

41. The first 5 terms in a number sequence are

10    7    4    1    -2    ...    ...

(a) Work out the  $n$ th term of the sequence.

.....  
(2)

(b) Find the 50<sup>th</sup> term of the sequence.

.....  
(2)

42. Expand and simplify  $(w - 8)(w + 7)$

.....  
(2)

---

43. Fully factorise  $10w^2 - 15w^3$

.....  
(2)

---

44. Factorise  $x^2 + 2x - 35$

.....  
(2)

---

45. Solve  $4y + 1 = 29 - 2y$

$y =$  .....  
(2)

46. A rectangle is shown below.

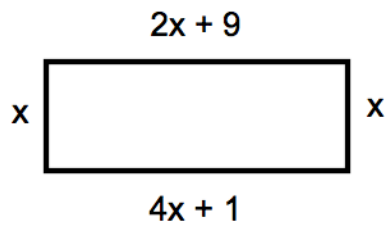

(a) Explain why  $4x + 1 = 2x + 9$

.....  
.....

(1)

(b) Find the size of  $x$ .

$x = \dots\dots\dots$ cm

(2)

(c) Work out the area of the rectangle.

$\dots\dots\dots$ cm<sup>2</sup>

(2)

---

47. Given that  $x = -6$  and  $y = -2$

Work out the value of  $x^2 + 3y$

.....  
(2)



48. Express  $v$  in terms of  $t$

$$t = \frac{v}{4} + 1$$

$v = \dots\dots\dots$   
(2)

49. The table gives information about the income of 200 households in a village.

Income (thousands)	Frequency
$0 < I \leq 20$	40
$20 < I \leq 40$	75
$40 < I \leq 60$	64
$60 < I \leq 80$	20
$80 < I \leq 100$	1

Draw a frequency polygon for the information in the table.

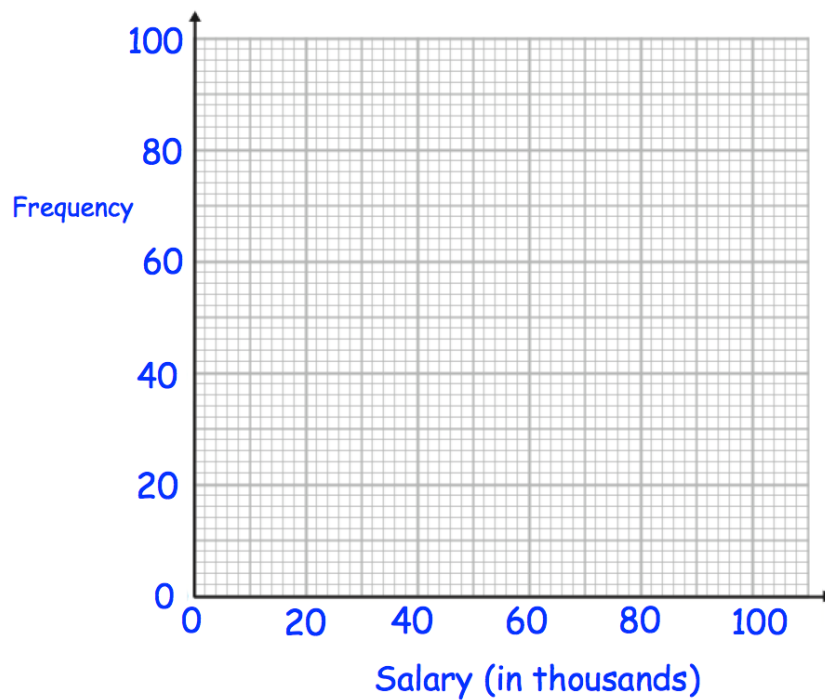

(2)

50. A fair 4-sided spinner is spun once.

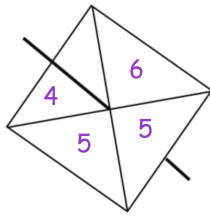

(a) On the probability scale, mark with a letter A, the probability that the spinner will land on the number 4.

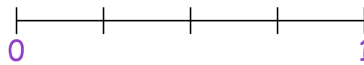

(1)

(b) Write down the probability that the spinner will land on a number less than 6

.....  
(1)

---

51. Shown below are five cards which are arranged in order from smallest to largest

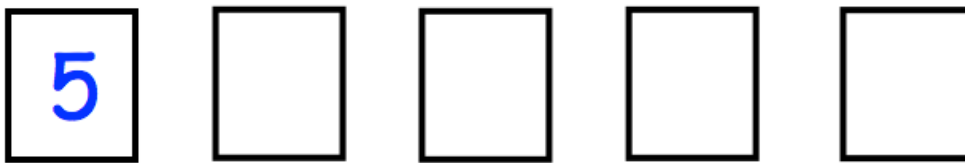

The range of the cards is 4.  
The median of the cards is 8.  
The mean of the cards is 7.

Work out the 4 missing numbers.

....., ....., ..... and .....  
(4)

52. A vet compares the masses of two breeds of dog, A and B.  
The table below shows the mean and range of their masses.

	Breed A	Breed B
Mean	15kg	23kg
Range	6kg	5kg

Diego says that “breed A is heavier than breed B because their range is larger.”

Is he correct?

(2)