

Name: _____

GCSE Maths 2022
OCR Foundation Paper 3
Set A
Calculator



Equipment

1. A black ink ball-point pen.
2. A pencil.
3. An eraser.
4. A ruler.
5. A pair of compasses.
6. A protractor.

Guidance

1. Read each question carefully.
2. Check your answers seem right.
3. Always show your workings

Information

1. This paper has been created based on topics in the Advance Information.
2. Also see Corbettmaths for the checklist for the entire GCSE as these topics may still be useful for Paper 3
3. There is one question per topic - this paper is designed to give an opportunity to practice each topic rather than replicate the actual paper.
4. The marks for questions are shown in brackets

GCSE 2022 Resources



1. A cinema has 16 seats in each row.
There are 24 rows.
During a movie, there are 45 empty seats.
Work out how many people watched the movie.

$$16 \times 24 = 384$$
$$384 - 45 = 339$$

339

.....
(3)

2. Bradley buys 12 rulers.
He pays with a £20 note.
His change is £14.60
What is the cost of one ruler?

$$2000 - 1460 = 540$$
$$540 \div 12 = 45p$$

45p

.....
(3)

3. In year 8 there are 197 students.
In year 9 there are 212 students.
In year 10 there are 235 students.
How many students are there in total in years 8, 9 and 10?

$$\begin{array}{r} 197 \\ 212 \\ 235 \\ + \\ \hline 644 \end{array}$$

644

.....
(2)

4. Grace is saving money for a new guitar.
The guitar costs £49.50

In January she saved £7.85

In February she saved £14.26

Work out how much more money Grace needs to save

$$7.85 + 14.26 = £22.11$$

$$£49.50 - £22.11 = £27.39$$

£27.39

(3)

5. (a) 1.7×1.5

$$\begin{array}{r} 17 \\ \times 15 \\ \hline 85 \\ 170 \\ \hline 255 \end{array}$$

2.55

(2)

- (b) $1.88 \div 0.8$

$$\begin{array}{r} 2.35 \\ 8 \overline{) 18.80} \end{array}$$

2.35

(2)

- (c) $14 \div 0.04$

$$1400 \div 4$$

350

(2)

6. From the list of numbers

3 5 7 9 11 15 24

(a) Write down a multiple of 8

24
.....
(1)

(b) Write down a factor of 28

7
.....
(1)

(c) Write down a factor of 81

9 or 3
.....
(1)

7. Write down all the prime numbers between 10 and 20.

11, 13, 17, 19
.....
(2)

8. Trains leave Bristol

to Cardiff every 15 minutes 3×5
to London every 21 minutes 3×7

A train to Cardiff and a train to London both leave Bristol at 11am.

At what time will a train to Cardiff and a train to London next leave Bristol at the same time?

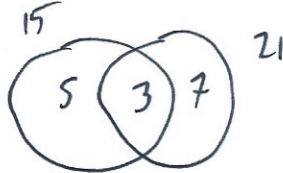

$$\text{LCM} : 5 \times 3 \times 7 = 105$$

1 hr 45 min

12:45 pm

(3)

9. (a) Calculate $2.8^3 + 9.1^2$

104.762

(2)

(b) Circle the value of 2^{-3} $\frac{1}{2^3}$

-6

$\frac{1}{8}$

-8

$\frac{1}{6}$

(1)

10. Work out $\frac{7}{20}$ of 860

$$860 \div 20 = 43$$

$$43 \times 7 = 301$$

301

.....
(1)

11. Hannah is baking two cakes.

One cake needs $1\frac{1}{3}$ cups of milk.

Hannah has $1\frac{1}{4}$ cups of milk.

How much more milk does Hannah need?

$$2 \times 1\frac{1}{3} = 2\frac{2}{3}$$

$$2\frac{2}{3} - 1\frac{1}{4} = \frac{8}{3} - \frac{5}{4}$$

$$= \frac{32}{12} - \frac{15}{12} = \frac{17}{12}$$

$1\frac{5}{12}$

.....cups

(3)

12.

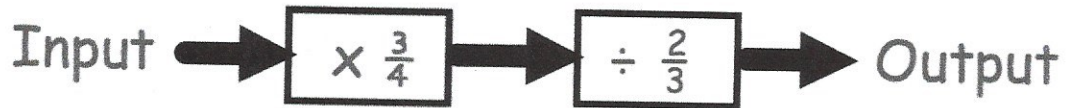

Find the output, if the input is 3.

$$3 \times \frac{3}{4} = \frac{9}{4}$$

$$\frac{9}{4} \div \frac{2}{3}$$

$$\frac{9}{4} \times \frac{3}{2} = \frac{27}{8}$$

$$\frac{27}{8} = 3\frac{3}{8}$$

.....

(3)

13. Work out

$$\frac{9}{10} \div \frac{2}{3}$$

$$\frac{9}{10} \times \frac{3}{2} = \frac{27}{20}$$

$$1\frac{7}{20}$$

.....

(3)

14. (a) Write $\frac{15}{16}$ as a percentage.

$$15 \div 16 = 0.9375$$

$$93.75\%$$

.....

(1)

(b) Write $\frac{9}{55}$ as a percentage.

$$9 \div 55 = 0.16363..$$

$$16.36...%$$

.....

(1)

15. Martina sat two maths tests.

Paper 1 has 60 marks.
Paper 2 has 150 marks } 210

Martina scored 65% in Paper 1 and 36% in Paper 2.

Her teacher has said to pass she will need to score 45% of the total marks.

Did Martina pass?

You need to show your working.

$$\begin{array}{r} 65\% \text{ of } 60 = 39 \\ 36\% \text{ of } 150 = 54 \\ \hline 93 \end{array}$$

$$45\% \text{ of } 210 = 94.5$$

No

.....
(4)

16. An empty bucket weighs 800g.
The weight of the bucket increases to 3.3kg when filled with water.

Calculate the percentage increase in the weight of the bucket.

$$\frac{2500}{800} \times 100$$

312.5%

.....
(3)

17. Carolyn invested £700 for 3 years at 2% per annum simple interest.

Work out the total amount of interest Carolyn earned.

$$2\% \text{ of } £700 = £14$$

$$£14 \times 3 = £42$$

£ 42
(3)

18. When a tennis ball is dropped, it bounces and then rises.
The ball rises to 80% of the height from which it is dropped.
The ball is dropped from a height of 4 metres.

- (a) Calculate the height of the rise after the first bounce.

$$4 \times 0.8$$

3.2m
(1)

- (b) Calculate the height of the rise after the second bounce.

2.56m
(1)

The ball carries on bouncing, each time rising to 80% of the last rise.

- (c) For how many bounces does the ball rise to a height greater than 2m?

$$2.56 \times 0.8 = 2.048$$

$$2.048 \times 0.8 = 1.6384$$

3
(2)

19. Charlotte and Melissa booked theatre tickets costing £400.
They have a voucher that entitles them to 20% off the total price.
Charlotte and Melissa share the total cost of the tickets in the ratio 1:4

Work out how much more Melissa pays than Charlotte.

$$20\% \text{ of } £400 = £80$$

$$400 - 80 = 320$$

$$1 + 4 = 5$$

$$320 \div 5 = 64$$

$$64 \times 1 = 64$$

$$64 \times 4 = 256$$

$$256 - 64$$

£192

(5)

20. Ella takes part in an archery lesson

For every 4 arrows fired, only 3 hit the target.
Altogether Ella hit the target 24 times.

Work out how many arrows Ella fired.

$$24 \div 3 = 8$$

$$8 \times 4 = 32$$

32

(2)

21. Work out

$$\frac{\sqrt{8^2 + 5^4}}{2.7^3}$$

Write down all the figures on your calculator display.

1.333577681

.....
(2)

22. A quadrilateral is drawn below.

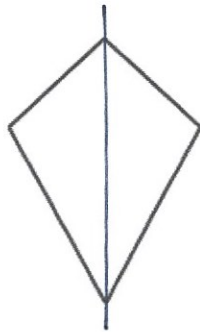

(a) Write down the name of this quadrilateral.

kite

.....
(1)

(b) Draw any lines of symmetry on the quadrilateral.

(1)

23.

$$180 - 132$$

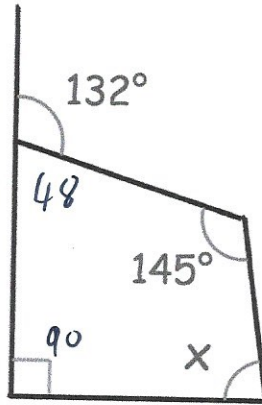

Find x

$$90 + 48 + 145 = 283$$

$$360 - 283 = 77$$

77

(3)

24. A design is made from some identical rectangles and identical squares.

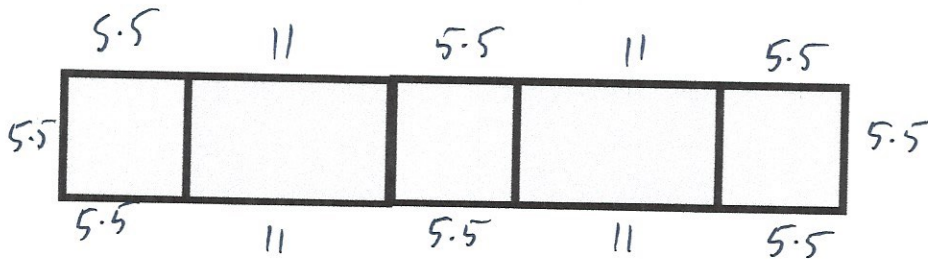

Each rectangle is twice as long as each square.

The perimeter of each square is 22cm. $\div 4 = 5.5$

Calculate the perimeter of the design.

$$5.5 \times 8 = 44$$

$$11 \times 4 = 44$$

88

cm

(4)

25. A quadrilateral is drawn below.
It has two pairs of parallel sides.

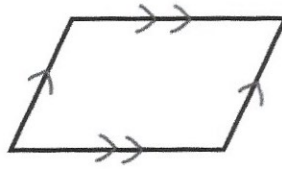

- (a) Write down the name of this quadrilateral.

Parallelogram
.....
(1)

- (b) How many lines of symmetry does the shape have?

0
.....
(1)

-
26. Sketch a quadrilateral with order of rotational symmetry, 2.



(1)

-
27. A solid glass cube has side length of 10cm.
The mass of the glass cube is 2.5kg.

Find the density of glass.
Give your answer in g/cm^3

$$V = 10 \times 10 \times 10 = 1000$$

$$2500 \div 1000 = 2.5$$

2.5
..... g/cm^3
(3)

28. Points A, B, C and D are four points on the circle with centre O.

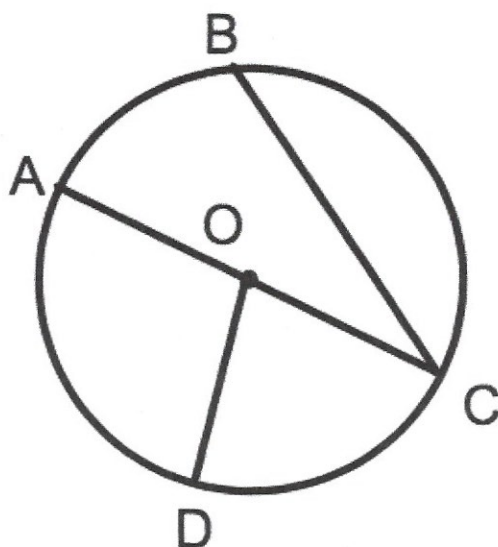

Here are six words that are used with circles.

Arc Diameter Chord Tangent Circumference Radius

Choose the correct word to describe each line below.

- (a) The straight line AC is a *diameter* of the circle. (1)
- (b) The straight line OD is a *radius* of the circle. (1)
- (c) The straight line BC is a *chord* of the circle. (1)

29. The diagram shows a prism.

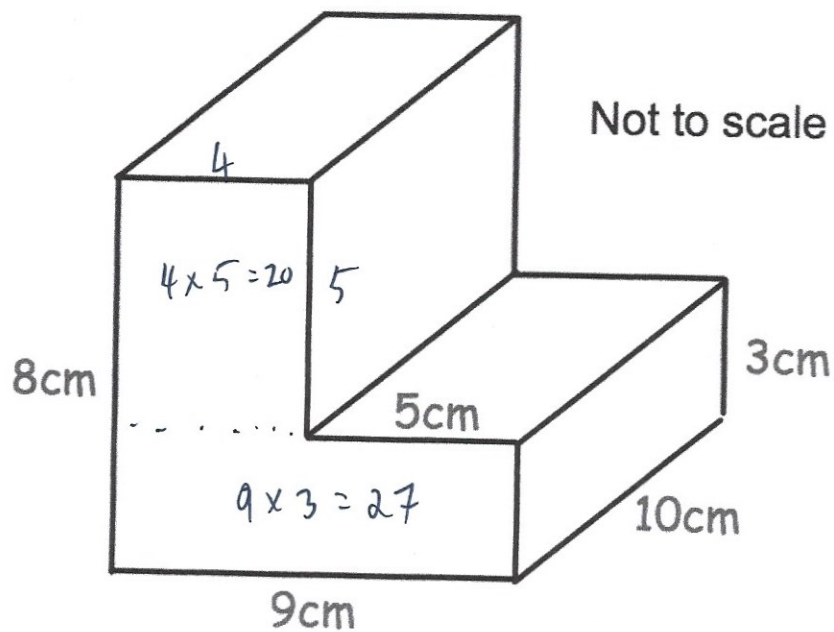

Work out the volume of the prism.

$$20 + 27 = 47$$

$$47 \times 10$$

$$\begin{array}{r} 470 \\ \hline \end{array} \text{cm}^3$$

(4)

30. Shown below is solid cuboid.

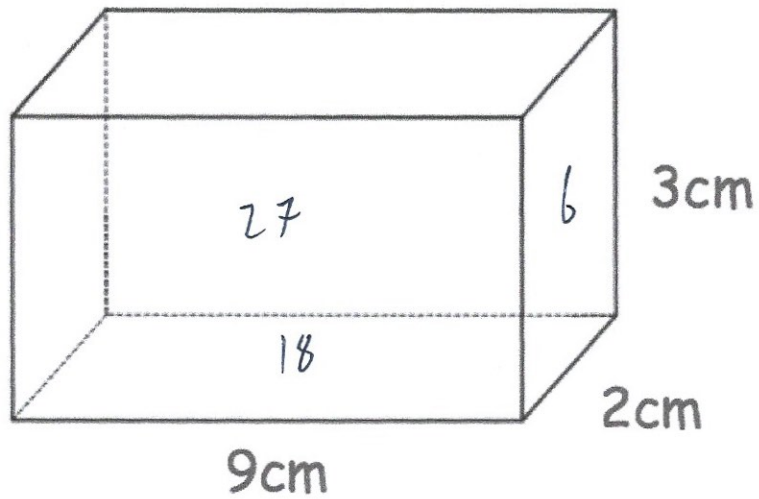

Work out the total surface area of the cuboid.

$$9 \times 2 = 18$$

$$9 \times 3 = 27$$

$$2 \times 3 = 6$$

$$18 + 18 + 27 + 27 + 6 + 6$$

$$\dots\dots\dots 102 \text{ cm}^2$$

(3)

31. A fair 4-sided spinner is spun once.

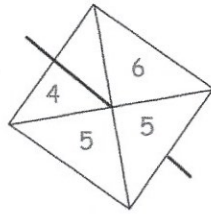

(a) On the probability scale, mark with a letter A, the probability that the spinner will land on the number 4.

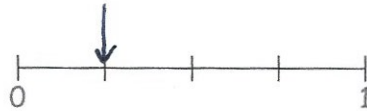

(1)

(b) Write down the probability that the spinner will land on a number less than 6

$$\frac{3}{4}$$

(1)

32. Abid goes to a coffee shop.
He chooses one drink and one snack.

Drink	Snack
Tea	Muffin
Coffee	Brownie
Juice	Crisps
	Pastry

Write down all the possible combinations.

TM TB TC TP

 CM CB CC CP

 JM JB JC JP

(2)

33. Shown below are five cards which are arranged in order from smallest to largest

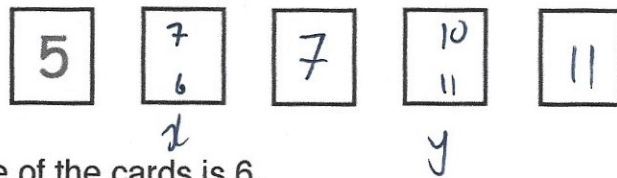

The range of the cards is 6.

The median of the cards is 7.

The mean of the cards is 8. $\times 5 = 40$

Work out the 4 missing numbers.

$$40 - 23 = 17$$

$$5 + 7 + 11 = 23$$

$$x + y = 17$$

$$\begin{array}{l} x = 7 \quad \text{and} \quad y = 10 \\ \text{or} \quad x = 6 \quad \text{and} \quad y = 11 \end{array}$$

(4)

34. The frequency table shows information about the amount of money withdrawn from an ATM by people on one day.

Money Withdrawn	Frequency
£10	16
£20	19
£30	4
£40	3
£50	6
£60	2

Write down the modal amount of money withdrawn.

£.....20.....

(1)

35. The table shows the ages of an under-21 rugby squad.

Age	Frequency
18	5
19	5
20	9
21	4

Find the median age.

~~18~~ ~~18~~ ~~18~~ ~~18~~ ~~18~~ ~~19~~ ~~19~~ ~~19~~ ~~19~~
~~20~~ ~~20~~ ~~20~~ ~~20~~ ~~20~~ ~~20~~ ~~20~~ ~~20~~ ~~20~~ ~~21~~ ~~21~~ ~~21~~

20

 (1)

36. There are 40 houses in Greenvale and 60 houses in Redville.

The mean number of cars per house in Greenvale is 1.25
 The mean number of cars per house in Redville is 1.75

Work out the mean number of cars per house in both villages.

$40 \times 1.25 = 50$
 $60 \times 1.75 = 105$
 $\underline{155}$

$155 \div 100$

1.55

 (3)

37. The time for ten students to complete a race is below.

Time (t seconds)	Frequency
20 < t ≤ 40	3
40 < t ≤ 60	5
60 < t ≤ 80	2

$$\begin{array}{r} f_x \\ 90 \\ 250 \\ 140 \\ \hline 480 \end{array}$$

Work out an estimate for the mean time taken.

$$480 \div 10 = 48$$

48
.....seconds
(4)

38. Jennifer is playing darts.
She throws two darts aiming for a Bullseye.

The probability Jennifer hits the Bullseye on her first throw is $\frac{1}{4}$.
The probability she hits the Bullseye on her second throw $\frac{1}{3}$.

(a) Complete the tree diagram.

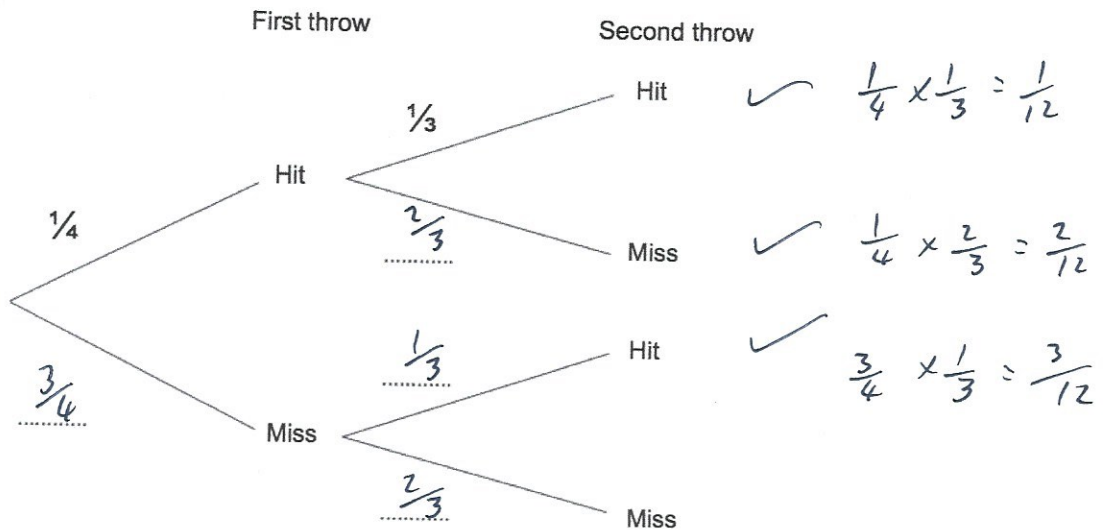

(b) Work out the probability Jennifer hits the Bullseye at least once.

$$\frac{6}{12}$$

$$\frac{1}{2}$$

(2)

39. Simplify $3y \times 9y^2$

$$27y^3$$

(1)

40. Here is a pattern of dots



(a) Continue the pattern to show Pattern 4



(2)

(b) How many dots will there be in Pattern 6?

$$1 \quad 5 \quad 9 \quad 13 \quad 17 \quad 21$$

$$4n - 3$$

$$\frac{21}{(1)}$$

(c) Which pattern will use 77 dots?

$$4n - 3 = 77$$

$$4n = 80$$

$$n = 20$$

$$\frac{20^{\text{th}}}{(1)}$$

(d) Explain why there will **not** be a pattern that uses 200 dots.

All the patterns have an odd number of dots.

.....

.....

(1)

41. Work out the n th term for this sequence

	13	23	33	43	53
$10n$	10	20	30				

$$\frac{10n+3}{\dots\dots\dots}$$

(2)

42. Expand $4x(3x - 7)$

$$\frac{12x^2 - 28x}{\dots\dots\dots}$$

(2)

43. Factorise $x^2 + 4x - 12$

$$\frac{(x+6)(x-2)}{\dots\dots\dots}$$

(2)

44. Three angles meet at a point.

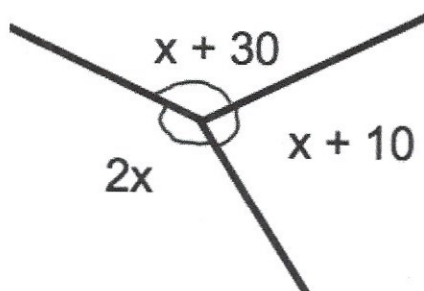

Calculate the size of the largest angle.

$$4x + 40 = 360$$

$$4x = 320$$

$$x = 80$$

$$2 \times 80 = 160$$

$$\underline{\quad 160 \quad}^{\circ}$$

(4)

45. Beth has a full padding pool.
The graph shows the depth of water in the pool (d cm) over time (t seconds)

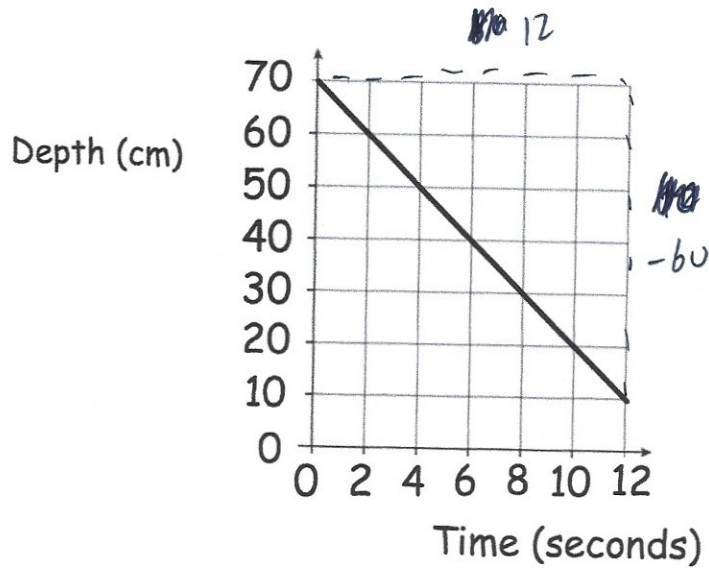

The graph intersects the vertical axis at 70

- (a) What does this represent?

The depth of a full pool.

(1)

- (b) Find the gradient of the line.

$$\frac{-60}{12} = -5$$

-5

(2)

- (c) Explain what the gradient represents.

The change in depth every second.

(1)

46. $v = u + at$

(a) Work out v when $u = 23$, $a = 4$ and $t = 3$

$$\begin{aligned}v &= 23 + 4 \times 3 \\ &= 23 + 12 \\ &= 35\end{aligned}$$

$$\begin{array}{r} 35 \\ \hline \end{array} \quad (2)$$

(b) Work out u when $v = 30$, $a = 2$ and $t = 8$

$$\begin{aligned}30 &= u + 2 \times 8 \\ 30 &= u + 16 \\ u &= 14\end{aligned}$$

$$\begin{array}{r} 14 \\ \hline \end{array} \quad (2)$$

(c) Work out t when $v = 40$, $u = 12$ and $a = 4$

$$\begin{aligned}40 &= 12 + 4t \\ 28 &= 4t \\ t &= 7\end{aligned}$$

$$\begin{array}{r} 7 \\ \hline \end{array} \quad (2)$$

47. Solve the simultaneous equations

$$\begin{array}{r} 3x + 5y = 1 \quad \times 3 \\ 2x - 3y = 7 \quad \times 5 \end{array}$$

Do not use trial and improvement

$$\begin{array}{r} 9x + 15y = 3 \\ 10x - 15y = 35 \\ \hline 19x = 38 \\ x = 2 \end{array}$$

$$\begin{array}{r} 4 - 3y = 7 \\ -3 = 3y \\ y = -1 \end{array}$$

$$x = \dots\dots\dots 2 \dots\dots\dots y = \dots\dots\dots -1 \dots\dots\dots$$

(4)

48. (a) Complete the table of values for $y = (x - 1)^2$

x	-2	-1	0	1	2	3
y	9	4	1	0	1	4

(2)

- (b) On the grid, draw the graph of $y = (x - 1)^2$ for the values of x from -2 to 3

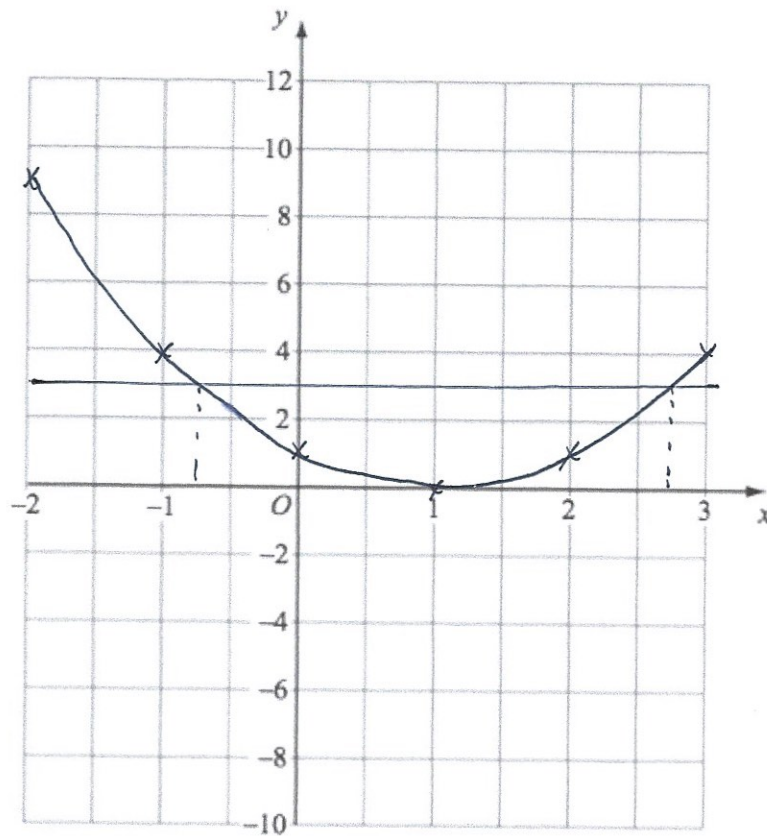

(2)

- (c) Use your graph to find estimates of the solutions to the equation $(x - 1)^2 = 3$

$$x = -0.75 \text{ or } x = 2.75$$

(2)