

GCSE Revision – A Bit of Everything

OCR
Foundation



This is a collection of questions from all the topics on the revision checklist

Guidance

1. Check your answers seem right.
2. Always show your workings
3. Take your time when working through this collection of questions

Revision for this test

www.corbettmaths.com/contents



Question	Topic	Video number
1	Place Value	222
2	Ordering Decimals	95
3	Negative Numbers	205 to 209
4	Factors	216
5	Function Machines	386
6	Cube Numbers and Cube Roots	212, 214
7	LCM, HCF	218, 219
8	Fractions, Decimals, Percentages	121 to 129
9	Recipes	256
10	Coordinates	84
11	Writing Expressions	16
12	Angles in a Triangle	37
13	Angles in a Quadrilateral	33
14	Bar Charts	147, 148
15	Symmetry	316, 317
16	Faces, Edges, Vertices	5, 3
17	Timetables	320
18	Distance Charts	318
19	Line Graphs	160
20	Translations	325, 326
21	Parts of the Circle	61
22	Nets	4
23	Multiplying Terms	18
24	Two-way Tables	319
25	Frequency Polygons	155, 156
26	Listing Outcomes	253
27	Collecting Like Terms	9
28	Mode, Median, Range, Mean	56, 50, 53, 57
29	Multiplication	199,200

Question	Topic	Video number
30	Division	98
31	Forming Equations	115
32	Types of Angle	38
33	Rounding	276, 277a, 277b, 278
34	Estimation	215
35	BODMAS	211
36	Arithmetic with Decimals	90, 91, 92, 93, 94
37	Multiples	220
38	Prime numbers	225
39	Square numbers and Square roots	226, 228
40	Product of primes	223
41	Fractions of Amounts	137
42	Adding Fractions	133
43	Multiplying Fractions	142
44	Dividing Fractions	134
45	Percentages of Amounts	234, 235
46	Ratio	269, 270, 271
47	Substitution	20
48	Probability	245, 246, 248
49	Scatter Graphs	165 to 168
50	Pictograms	161, 162
51	Frequency Trees	376
52	Units	347, 349
53	Area of Rectangles/Triangles	45, 49
54	Angles in Polygons	32
55	Angle Facts	35, 30, 34, 39
56	Speed, Distance, Time	299
57	Estimated Mean	55
58	Venn Diagrams	380
59	Tree Diagrams	252

Question	Topic	Video number
60	Currency	214a
61	Drawing Linear Graphs	186
62	Reverse Percentages	240
63	Ratio	269, 270, 271
64	Percentage Change	233
65	Negative Indices	175
66	Expanding Two Brackets	14
67	Equations (letters both sides)	113
68	nth term	288
69	Factorising	117
70	Factorising Quadratics	118
71	$y = mx + c$	191
72	Solving Inequalities	178
73	Conversion Graphs	151
74	Difference between 2 Squares	120
75	Compound Interest	236
76	Standard Form (operations)	301, 302, 303
77	Cubic Graphs	344
78	Reciprocal Graph	346
79	Angles in Parallel Lines	25
80	Constructions	72, 78
81	Loci	75, 76, 77
82	Surface Area	310
83	Density	384
84	Pressure	385
85	Volume of a Prism	356
86	Enlargements	104, 105, 107
87	Circumference	60
88	Views	354
89	Area of Compound Shapes	41

Question	Topic	Video number
90	Volume of a Cylinder	357
91	Trigonometry	329, 330, 331
92	Arc Length	58
93	Area of a Sector	46
94	Surface area of Solids	313, 314
95	Volume of Spheres/Cones	359, 361
96	Vectors (Columns)	353a
97	Reflections	272, 273
98	Rotations	275
99	Congruent Triangles	67
100	Similar Shapes	292
101	Quadratic Graphs	264
102	Simultaneous Equations	295
103	Changing the Subject	7
104	Forming Equations	114, 115
105	Parallel Graphs	196
106	Pie Charts	163, 164
107	Indices	172, 174
108	Exact Trig Values	341
109	Pythagoras	257
110	Area of a Circle	59
111	Bearings	26, 27
112	Area of a Trapezium	48
113	Error Intervals	377
114	Best Buys	210
115	Use of a Calculator	352
116	Ratio - Problem Solving	269, 270, 271

1. Here are four different digits.

8 1 5 6

(i) Put one digit in each box to make the **smallest** total.
You may only use each digit once.

		+		
--	--	---	--	--

(1)

(ii) Write down the total

.....
(1)

2. The heights of 7 children are shown below.

132cm 1.2m 98cm 0.99m 116cm 1.4m 1.33m

(a) Change 132cm into metres.

.....m
(1)

(b) Change 98cm into metres.

.....m
(1)

(c) Order the heights, starting with the shortest.

.....
(1)

(d) Work out the median.

.....
(1)

Children over 1 metre may go on a ride at a funfair.

(e) What fraction of the children may not go on the ride.

.....
(1)

3. The temperature, in °C, at midnight at a weather station on 5 days was recorded

Day	Monday	Tuesday	Wednesday	Thursday	Friday
Temperature	-4	1	-6	1	-2

(a) What fraction of the days had a temperature below 0°C?

.....
(1)

(b) What is the range of the temperatures?

.....°C
(1)

4. From the list of numbers

3 5 7 9 11 15 24

(a) Write down a factor of 12

.....
(1)

(b) Write down a factor of 28

.....
(1)

(c) Write down a factor of 81

.....
(1)

5.

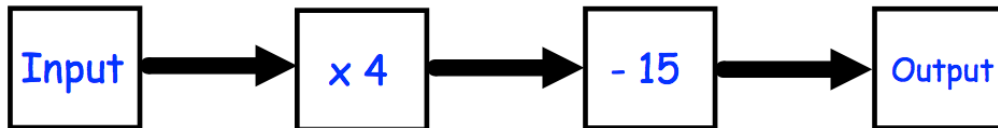

(a) Work out the output, when the input is 10.

.....
(1)

(b) Work out the input, when the output is 25.

.....
(1)

(c) If the input is the same as the output, work out the input.

.....
(1)

6. Don says

“the difference between two consecutive cube numbers is even.”

Is Don correct?

You must show your workings.

(2)

7. Trains leave Bristol

to Cardiff every 15 minutes
to London every 21 minutes

A train to Cardiff and a train to London both leave Bristol at 11am.

At what time will a train to Cardiff and a train to London next leave Bristol at the same time?

.....
(3)

8. Penny gets £8 pocket money.
She is given an increase of £3.

(a) Write down £3 as a fraction of £8

.....
(1)

(b) Write your answer as a percentage

.....
(1)

9. Jo has a recipe for Bolognese Sauce,

Bolognese Sauce

Minced Beef	500 g
Chopped Tomatoes	750 g
Mushrooms	40 g
Chicken Stock	150 ml

She only has 400g of minced beef.

How much of the other ingredients should she use?

Chopped Tomatoes:g

Mushrooms:g

Chicken Stock:g

(3)

10. The points A (-3, 2), B (-1, 4) and D (-1, -3).

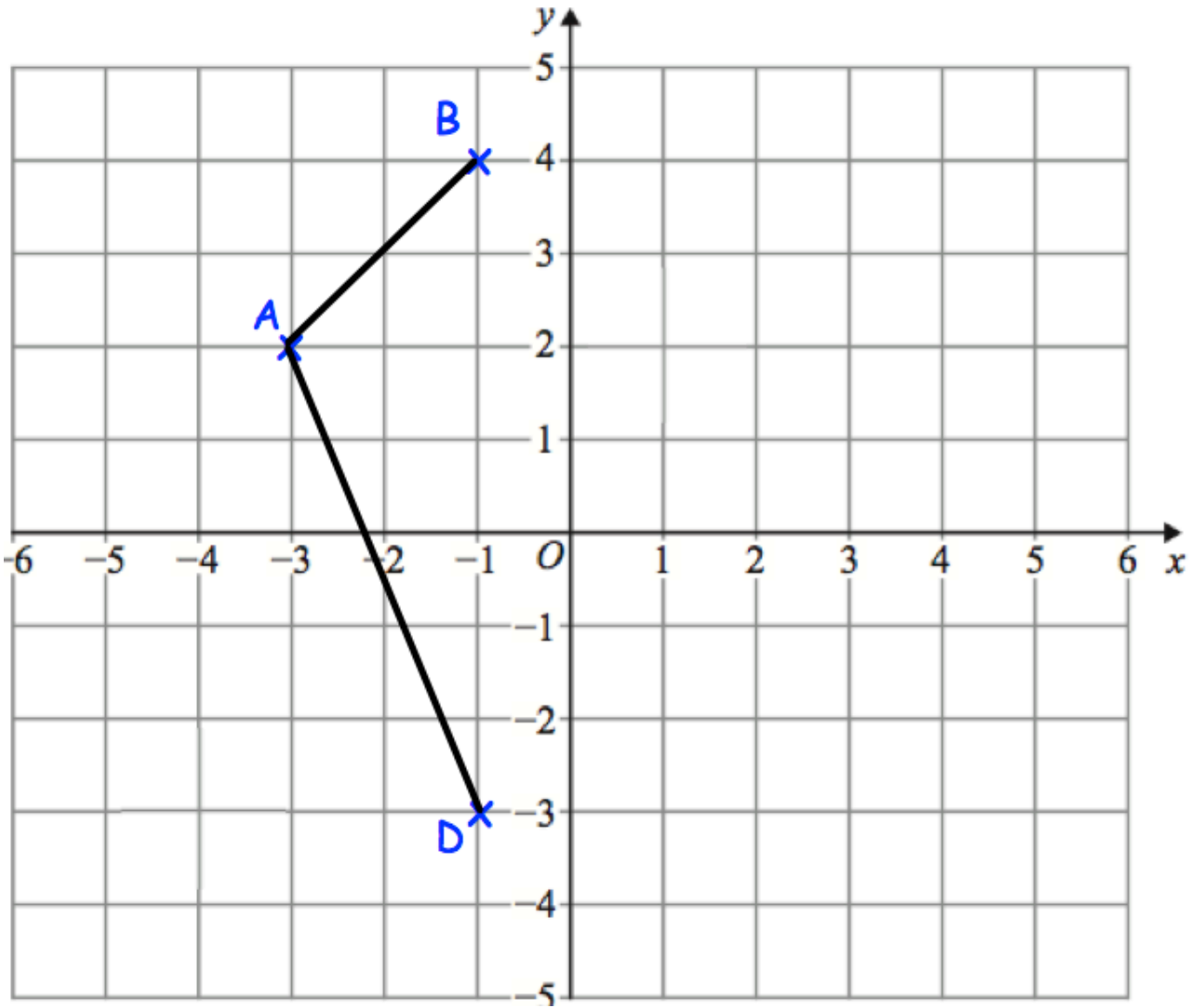

ABCD is a kite.
Complete the kite and write down the coordinates of C.

(.....,)
(2)

11. An airplane has economy and first class seating.
There are s seats in each row in economy.
There are t seats in each row in first class.

There are 9 rows in first class and 24 rows in economy.

Write down an expression, in terms of s and t , for the number of seats on the airplane.

.....
(2)

12.

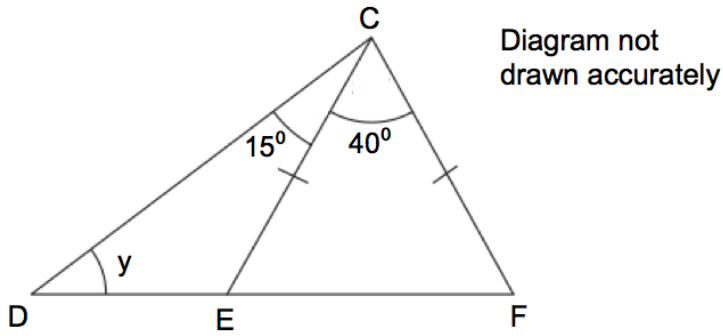

DEF is a straight line.

$CE = CF$.

Angle ECF is 40° .

Angle DCE is 15° .

Find the size of the angle marked y .

.....⁰
(4)

13. Shown below is a kite.

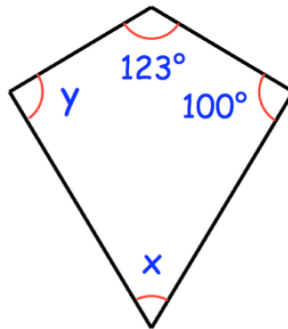

(a) Find x

.....⁰
(1)

(b) Find y

.....⁰
(1)

14. Miss Jackson asked the 32 students in her tutor group which language they study.

Each student studies one language only.

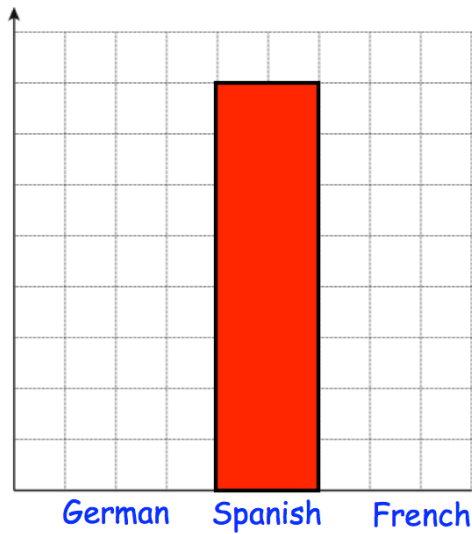

Half of the students in the tutor group study Spanish.
Six more students study German than French.

Complete the bar chart.

(4)

15. The diagram below shows a regular hexagon.

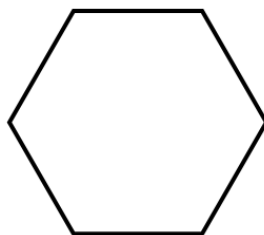

(a) Write down the order of rotational symmetry of the hexagon.

.....
(1)

(b) On the diagram draw in all the lines of symmetry.

(2)

16. Complete the table below.

	Faces	Edges	Vertices
Cube			8
Square-based Pyramid	5		
Triangular Prism		9	

(6)

17. Here is part of a train timetable.

	Departure times			
Antrim	12:30	13:00	14:00	16:00
Randalstown	12:45	13:15	14:15	16:15
Ballymena	13:01	13:31	14:31	16:31
Ballycastle	13:39	14:09	15:09	17:09

Freddy wants to travel from Randalstown to Ballycastle.

He arrives at Randalstown at 13:03 to catch the next train to Ballycastle.

(a) How long does this train journey take?

.....minutes

(2)

Jennifer lives in Antrim and her friend lives in Ballymena.

Jennifer lives a 5 minute walk from Antrim train station.

Her friend lives a 30 minute walk from Ballymena train station.

Jennifer wants to arrive at her friend's house **before** 3pm.

Plan Jennifer's journey to her friend's house.

(5)

18. Here is a route map between four towns.

The distances, in kilometres, between some of the towns are shown on the map.

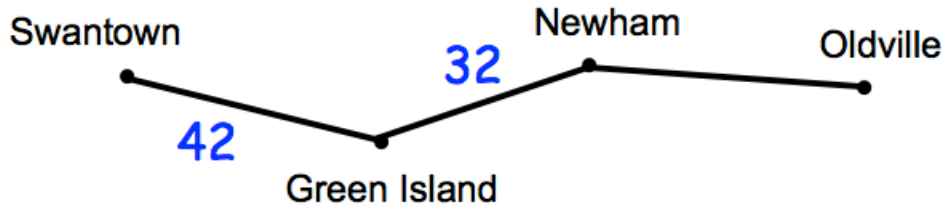

The distance from Swantown to Oldville is 95 kilometres.

(a) Work out the distance from Newham to Oldville.

..... kilometres
(2)

(b) Complete the distance chart below to show the distances between the towns.

Swantown			
42	Green Island		
	32	Newham	
			Oldville

(3)

19. The table shows the average price of unleaded petrol in England over 5 years.

Year	Price in pence
2011	111
2012	128
2013	133
2014	132
2015	108

(a) Draw a line graph for the data

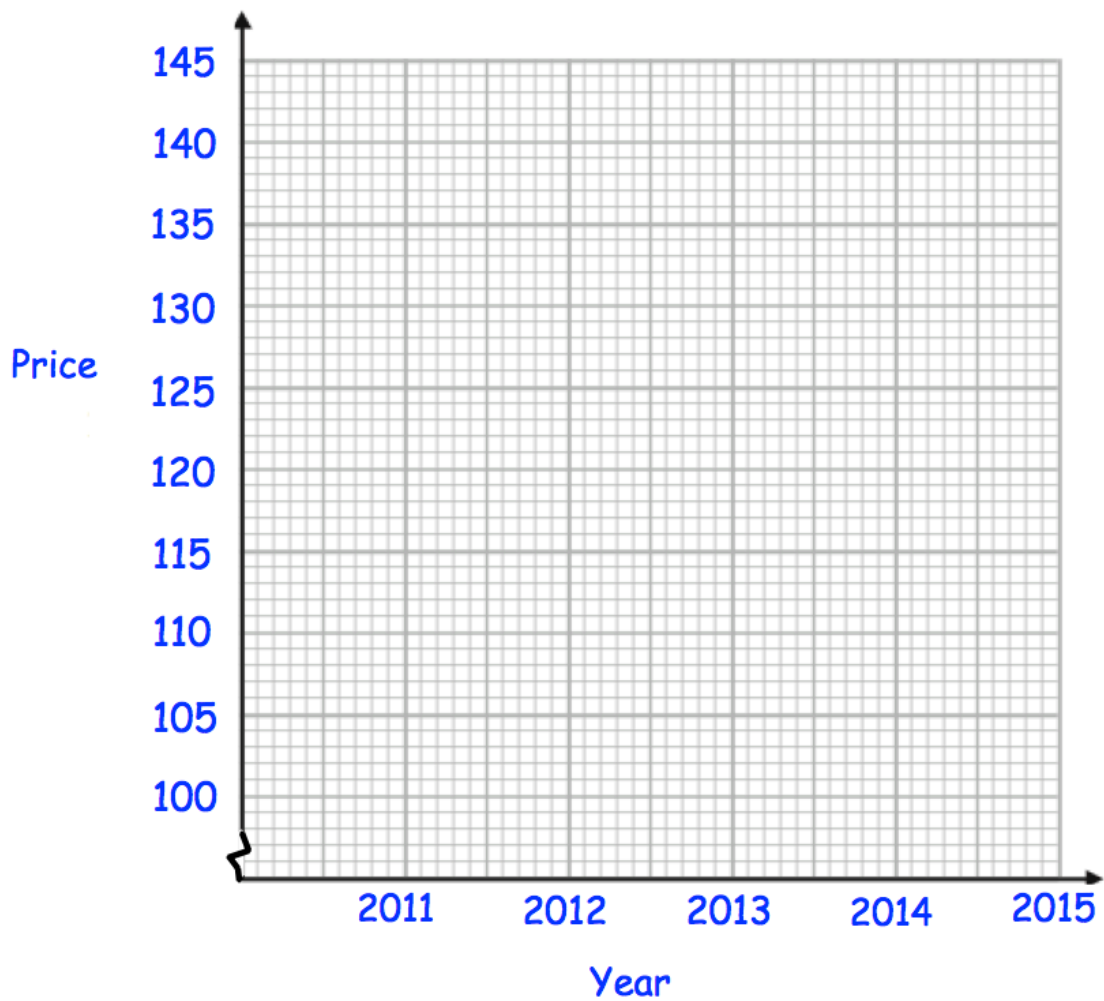

(2)

(b) Between which two consecutive years did the price increase the most?

..... and
(1)

20.

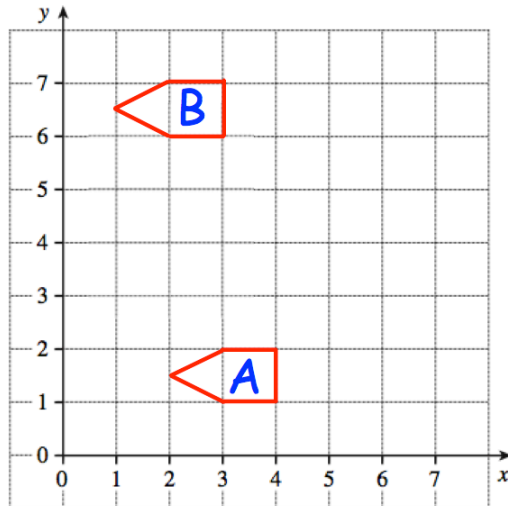

Write down the translation vector that would take A to B.

$$\begin{pmatrix} \dots\dots\dots \\ \dots\dots\dots \end{pmatrix}$$

(1)

21. Here is a list of words connected to circles.

Tangent Radius Diameter Chord Centre Circumference

Label the four boxes in the diagram below, by choosing the correct word from the list.

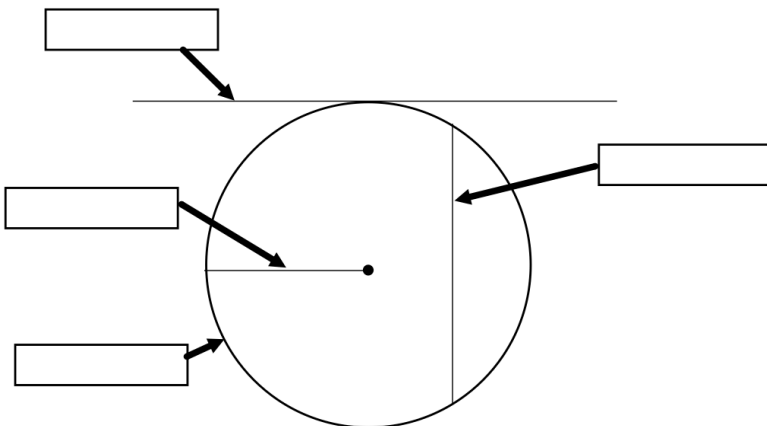

(4)

22. Here are 4 diagrams.

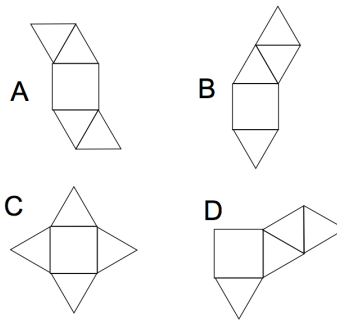

Three of these diagrams show a net for a square-based pyramid.

Write down the letter of the diagram which is **not** a net for a square-based pyramid.

.....
(1)

23. Simplify

(a) $8 \times y \times 2$

.....
(1)

(b) $a \times a \times a$

.....
(1)

(c) $3 \times a \times c$

.....
(1)

(d) $w \times 5 \times e$

.....
(1)

(e) $2y \times y$

.....
(1)

(f) $3a \times 4c$

.....
(1)

24. 100 people study one language at a college.

Some people study French.

Some people study Spanish.

The rest of the people study German.

54 of the people in Year 10 and the rest are in Year 11.

20 of the 29 people who study Spanish in Year 11.

31 people study German.

15 Year 11 students study French.

Work out the number of Year 10's who study German.

.....
(4)

25. The table gives information about the income of 200 households in a village.

Income (thousands)	Frequency
$0 < I \leq 20$	40
$20 < I \leq 40$	75
$40 < I \leq 60$	64
$60 < I \leq 80$	20
$80 < I \leq 100$	1

Draw a frequency polygon for the information in the table.

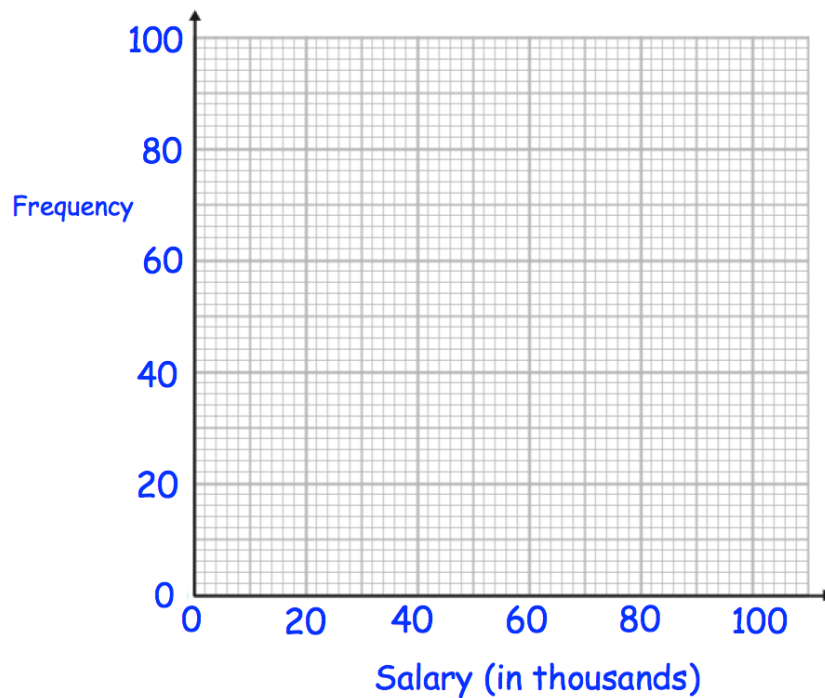

(2)

26. Magnus flips a fair coin once and rolls an ordinary dice once.

(a) Write down all the possible outcomes.

.....

.....

.....

(2)

(b) Find the probability that Magnus gets a head and a 3.

.....

(1)

27.

(a) Simplify $8a + 3c - 5c + 3a$

.....
(2)

(b) Simplify $3a + 2w - 5a - 9w$

.....
(2)

(c) Simplify $3y^2 + 2w^2 + y^2 - w^2$

.....
(2)

28. Hannah is recording the number of letters in each word in an article.

These are the first ten lengths.

3 4 5 6 2 4 3 7 3 6

(a) Work out the median.

.....
(2)

(b) Calculate the mean.

.....
(2)

The 11th word has 4 letters.

(c) Tick the box which describes what affect this will have on the mean.

The mean will
decrease

The mean will
remain the same

The mean will
increase

(1)

(d) Tick the box which describes what affect this will have on the median.

The median will
decrease

The median will
remain the same

The median will
increase

(1)

-
29. James bought a motor scooter on hire purchase.
He paid a deposit of £275 and 18 monthly payments of £36.

At the end of the payments, he sold the motor scooter for £450.

How much did it cost him in total?

£.....

(3)

30. Paul has £10 to buy rulers at 60p each.

What change should he get if he buys as many as possible?

.....
(3)

31. James has x pence.
Hannah has 5 pence more than James.
Liam has 2 pence less than James.

The total amount of money they have is 75 pence.

(a) Use this information to write down an equation in x .

.....
(2)

(b) Solve the equation to find out how much money James has.

.....pence
(2)

32. Here is a trapezium.

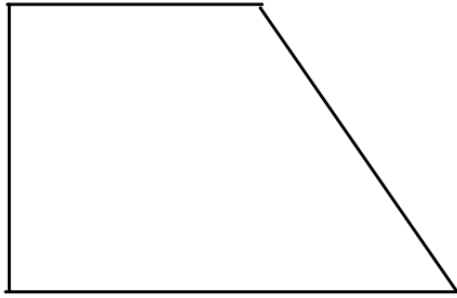

(a) Mark a right angle with a letter R. (1)

(b) Mark an acute angle with a letter A. (1)

(c) Mark an obtuse angle with a letter O. (1)

33. (a) Write 5725 to the nearest 100.

.....
(1)

(b) Write 83.07718 correct to two decimal places.

.....
(1)

(c) Write 6.35 correct to 1 decimal place.

.....
(1)

(d) Write 129.34952 correct to 1 decimal place.

.....
(1)

34. Work out an estimate for

$$\frac{596.4 \times 2.06}{0.521}$$

.....
(3)

35. Work out

(a) $(2 + 5)^2$

.....
(1)

(b) $5 + 3 \times 6$

.....
(1)

(c) $22 - 14 \div 2$

.....
(1)

36. Timothy orders the following items at a restaurant.

- 4 pizzas at £4.49 each.
- 2 garlic breads at £3.10 each.
- 2 orange juices at £1.19 each.
- 2 sparkling water at 99p each.

Complete the bill below.

Corbett Cuisine		
	£	pence
4 pizzas at £4.49	17	96
2 garlic bread at £3.10		
2 orange juice at £1.19		
2 sparkling water at 99p		
Total		

(4)

37. From the list of numbers

7 9 12 21 23 30 36 45

(a) write down the multiples of 7.

.....
(2)

(b) write down the multiples of 5.

.....
(2)

38. Sort **all** the numbers into the correct boxes.

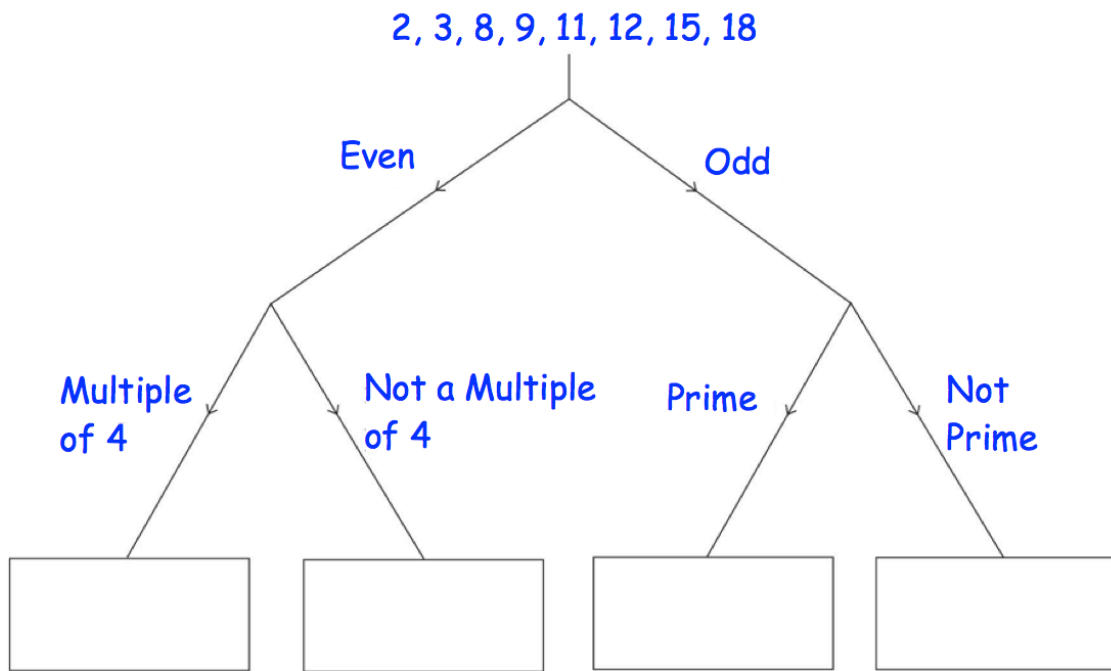

(3)

39. Arrange these in order, starting with the smallest.

3^2

$\sqrt{100}$

4^2

$\sqrt{80}$

.....
(2)

40. (a) Write 60 as a product of its prime factors.

.....
(2)

(b) Find the Lowest Common Multiple (LCM) of 60 and 75.

.....
(2)

41. Bill is 80 years old.

His son Max is $\frac{5}{8}$ of his age.

His granddaughter Jayne is $\frac{1}{5}$ of his age.

How many years older than Jayne is Max?

.....
(4)

42. Work out, as a simplified fraction.

$$\frac{3}{4} + \frac{2}{9}$$

.....
(2)

43. Work out

$$1\frac{1}{3} \times 2\frac{2}{5}$$

Give your answer as a mixed number.

.....
(3)

44. Work out

$$\frac{2}{17} \div \frac{2}{5}$$

Give your answer as a fraction in its simplest form.

.....
(2)

45. At Frome International train station, 35% of trains were late in a week.
In that week there were 440 trains.

Calculate how many trains were on time.

.....
(3)

46. At a rugby match, the ratio of children to adults is 2 : 3
There are 80 children in the crowd.
Each adult ticket costs £8
Each child ticket costs a quarter of the adult ticket.

Work out the total money made from ticket sales.

£.....
(4)

47. $v = u + at$

(a) Work out v when $u = 23$, $a = 4$ and $t = 3$

.....
(2)

(b) Work out u when $v = 30$, $a = 2$ and $t = 8$

.....
(2)

(c) Work out t when $v = 40$, $u = 12$ and $a = 4$

.....
(2)

48. Tony makes a fair six-sided spinner.
The spinner has the numbers 7, 8 and 9 on it.

The probability the spinner will land on 7 is greater than the probability that the spinner will land on 8.

The probability that the spinner will land on 9 is $\frac{1}{3}$

Write the numbers on the spinner.

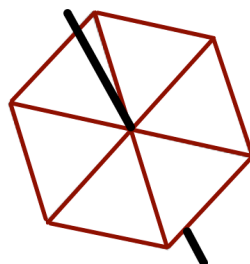

(2)

49. The table shows the charge (£) by plumbers for jobs of different duration (hours).

Job duration (hours)	1	2	3	3	5	6	6
Charge (£)	60	80	104	116	128	140	160

(a) Plot the data on the scatter graph below.

(2)

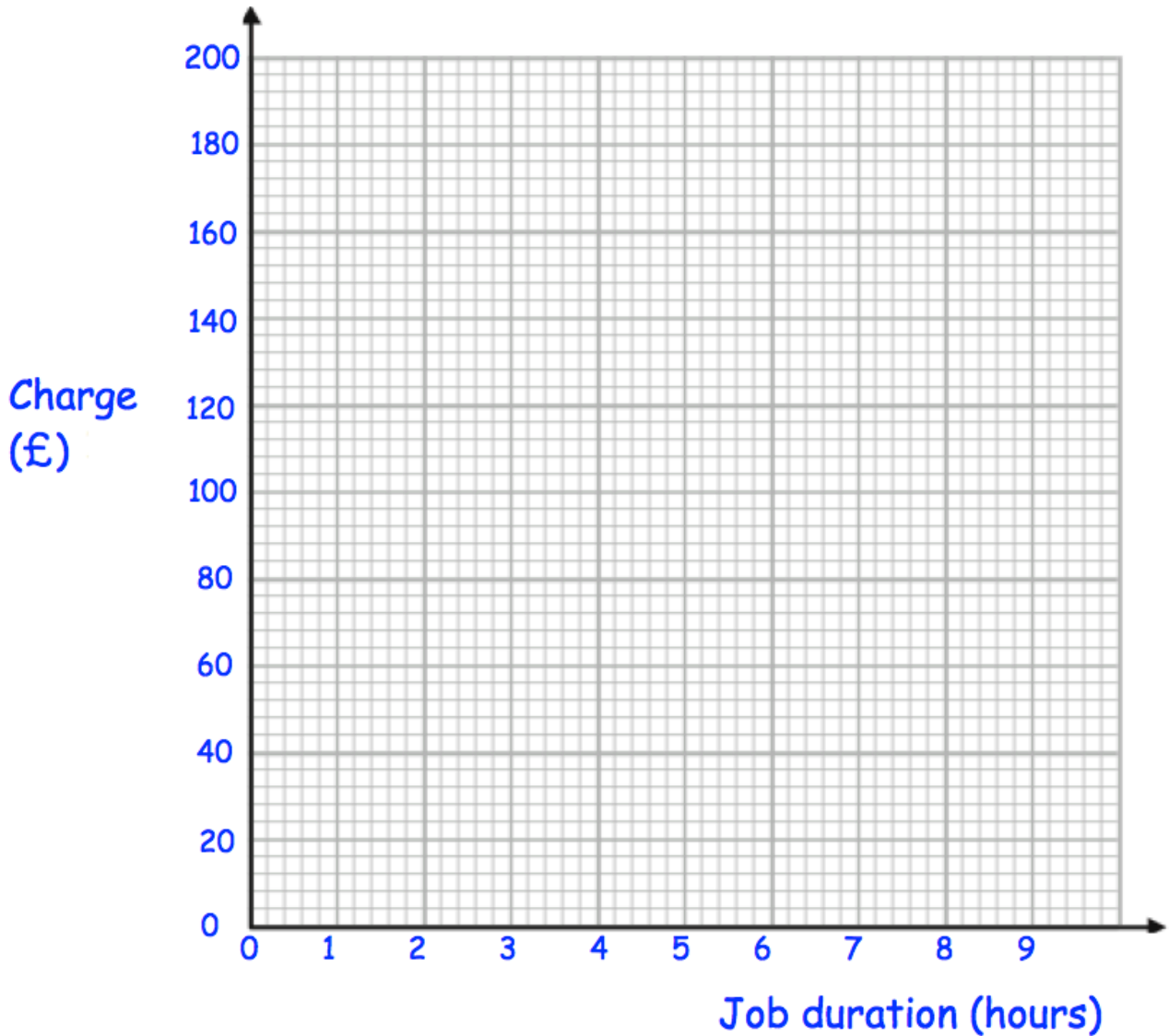

(b) Describe the correlation.

.....

.....

(1)

(c) Draw a line of best fit on the scatter graph.

(1)

(d) Use your line of best fit to estimate the charge for a 4 hour job.

£.....

(1)

(e) Explain why it may **not** be appropriate to use your line of best fit to estimate the charge for a job lasting 12 hours.

.....

.....

(1)

50. The number of hours of sunshine on a day, across a number of cities is shown below.

 = 2 hours of sunshine

Norwich	      
Dublin	   
Belfast	   
Aberdeen	 
Cardiff	   
Glasgow	

(a) How many more hours of sunshine was there in Norwich than Belfast?

.....hours

(1)

In Glasgow there was 9 hours of sunshine.

(b) Complete the pictogram.

(2)

51. 124 people took part in a talent show.
 Each person either sang or danced.
 76 of the people were singers.
 14 people made it through to the final and the rest were eliminated.
 6 dancers made it through to the final.

Complete the frequency tree

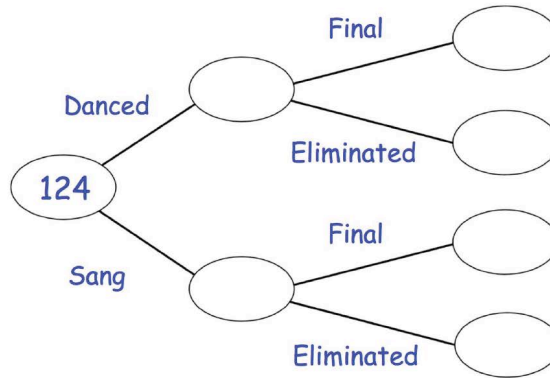

a) Complete the frequency tree

(2)

b) What fraction of the singers made it through to the final?

.....
 (2)

52.

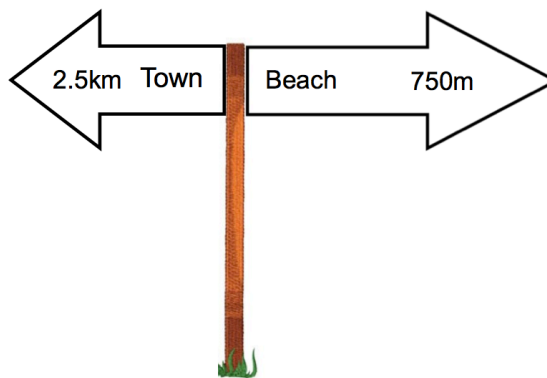

Work out the distance between the town and the beach.
 State your units.

.....
 (3)

53. Shown below is a right-angled triangle.

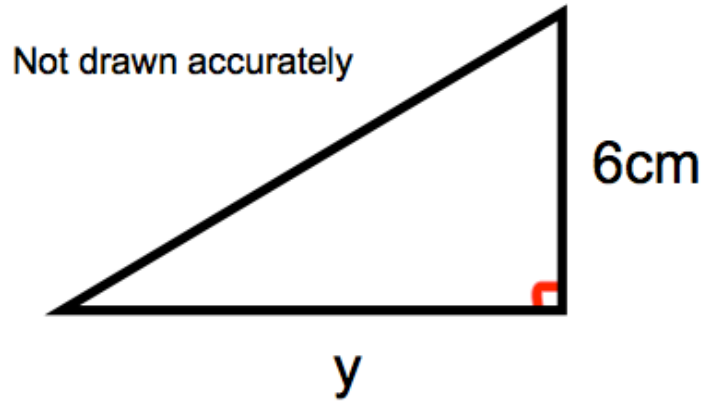

The area of the triangle is 21cm^2
Calculate y , the length of the base.

.....cm
(2)

54. Shown below is a regular pentagon.

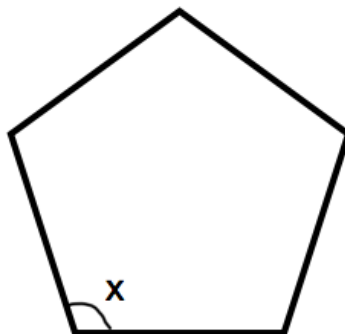

(a) Find the size of each interior angle.

$x = \dots\dots\dots^\circ$
(2)

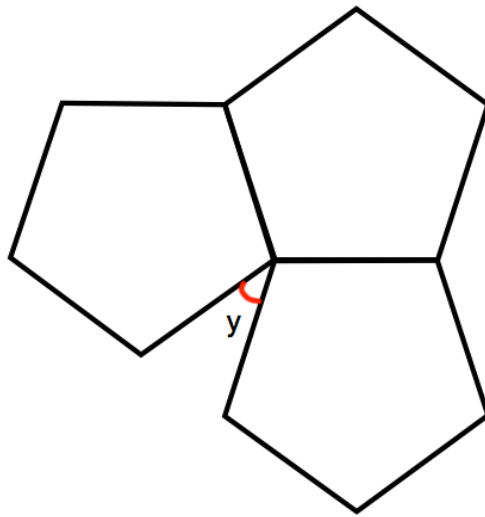

Three identical regular pentagons are joined as shown above.

(b) Work out the size of angle y .

$y = \dots\dots\dots^\circ$
(2)

55.

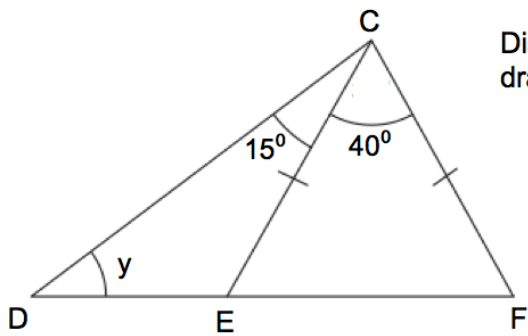

Diagram not drawn accurately

DEF is a straight line.
 $CE = CF$.
 Angle ECF is 40° .
 Angle DCE is 15° .

Find the size of the angle marked y .

$\dots\dots\dots^\circ$
(4)

56. A car travels 240 kilometres in 3 hours 45 minutes

Calculate the average speed, in km/h, of the car.

.....km/h
(3)

57. The time for ten students to complete a race is below.

Time (t seconds)	Frequency
$20 < t \leq 40$	3
$40 < t \leq 60$	5
$60 < t \leq 80$	2

Work out an estimate for the mean time taken.

.....seconds
(4)

58. Here is a Venn diagram.

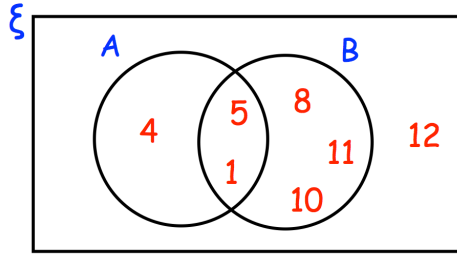

A number is chosen at random.

(a) Write down $P(A \cap B)$

.....
(2)

(b) Write down $P(A \cup B)$

.....
(2)

59. Jennifer is playing darts.
She throws two darts aiming for a Bullseye.

The probability Jennifer hits the Bullseye on her first throw is $\frac{1}{4}$.
The probability she hits the Bullseye on her second throw $\frac{1}{3}$.

(a) Complete the tree diagram.

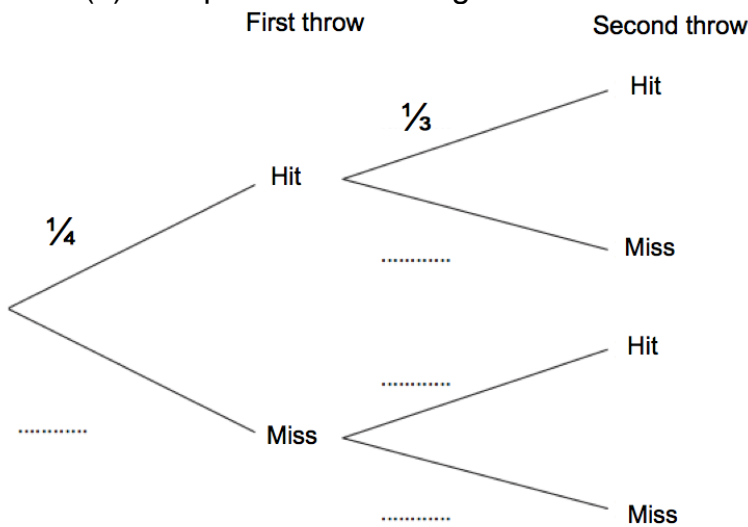

(b) Work out the probability Jennifer hits the Bullseye at least once.

.....
(2)

60. James is going on holiday in New York.
James changes £400 into dollars (\$).

The exchange rate is £1 = \$1.38

Work out how many dollars (\$) James will receive.

(2)

-
61. On the grid, draw $y = 4x - 5$ for values of x from -2 to 2 .



(4)

62. A fish tank sprung a leak and loses 20% of its water.
There is now 240 litres of water in the fish tank.

How much water was in the fish tank before the leak?

.....|
(3)

-
63. A piece of carpet is 240cm long.
Mr Jones cuts it into three pieces in the ratio 1 : 2 : 5

Work out the length of the longest piece of carpet.

.....
(3)

-
64. Peter's weight decreases from 80kg to 64kg.

Calculate the percentage decrease in Peter's weight.

.....%
(2)

-
65. Work out

$$4^{-2}$$

.....
(1)

66. Expand and simplify $(w - 6)(w + 7)$

.....
(2)

67. Solve $4y + 1 = 29 - 2y$

$y =$
(2)

68. Work out the n th term for this sequence

12 22 32 42 52

.....
(2)

69. Factorise fully

$$9m^2 - 12mp$$

.....
(2)

70. Factorise $x^2 + 4x - 12$

.....
(2)

71. A straight line L is shown on the grid.



Work out the equation of line L

.....
(3)

72. Solve the inequality $4x + 6 \geq 8$

.....
(2)

73. Shown below is a conversion to change between kilograms and pounds.



(a) Using the graph, convert 5 kilograms to pounds.

.....pounds
(1)

(b) Using the graph, convert 8 pounds to kilograms.

.....kilograms
(1)

A piano weighs 150 kilograms.

(c) Change 150 kilograms to pounds.

.....pounds
(2)

74. Factorise $x^2 - 121$

.....
(2)

75. Sebastian leaves £3000 in the bank for two years.
It earns compound interest of 2% per year.

Calculate the total amount Sebastian has in the bank at the end of the two years.

£.....
(2)

76. Write the following numbers in standard form.

(a) 40000

.....
(1)

(b) 5600

.....
(1)

(c) 41200000

.....
(1)

(d) 0.00000008

.....
(1)

77. (a) Complete the table of values for $y = x^3 + 2x^2 - 1$

x	-3	-2	-1	0	1	2
y						

(2)

(b) On the grid, draw the graph of $y = x^3 + 2x^2 - 1$ for the values of x $-3 \leq x \leq 2$

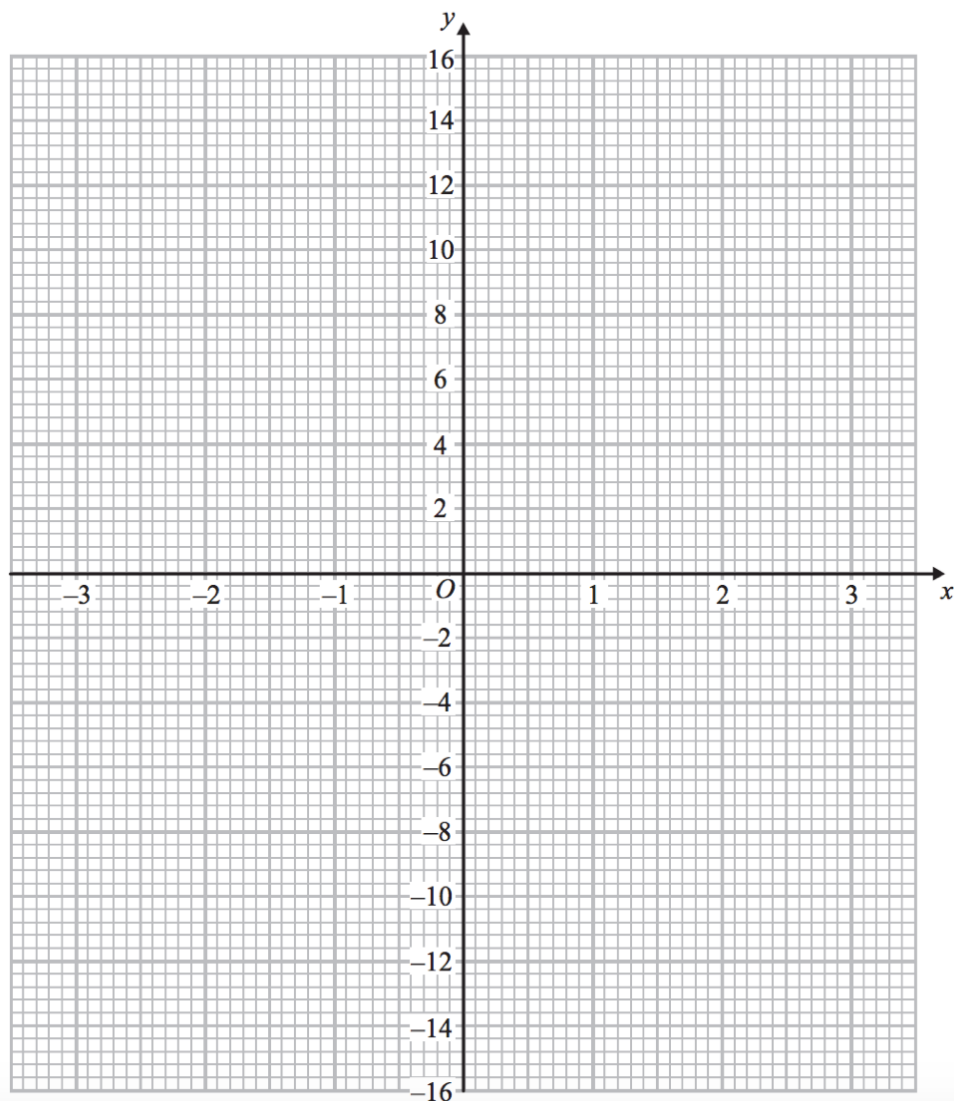

(2)

78. Complete the table of values for $y = \frac{5}{x}$

x	0.5	1	2	4	8	10
y						

(2)

(b) On the grid, draw the graph of $y = \frac{5}{x}$ for $0.5 \leq x \leq 10$

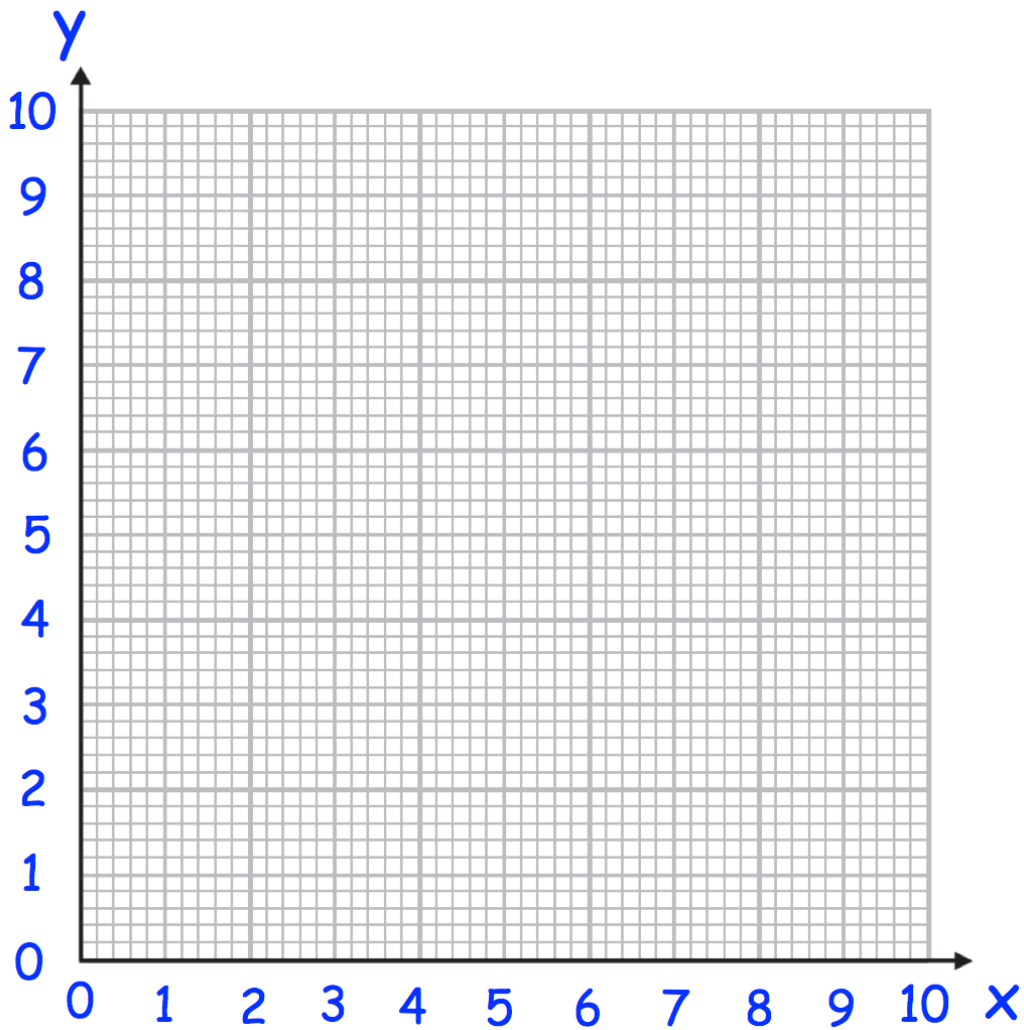

(2)

79. In the diagram AB is parallel to CD.

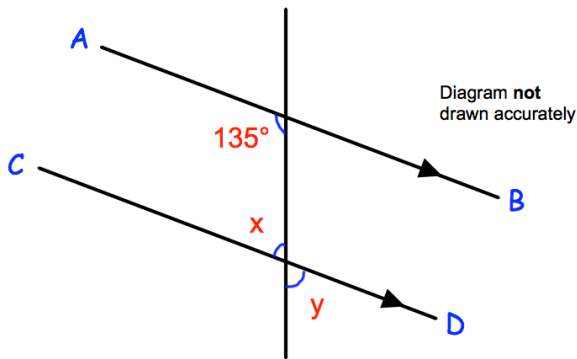

(a) Work out the size of the angle marked x.

.....°

Give a reason for your answer.

.....
(2)

(b) Write down the value of y.

.....°

Give a reason for your answer.

.....
(2)

80. Using ruler and compasses, construct the bisector of angle ABC.

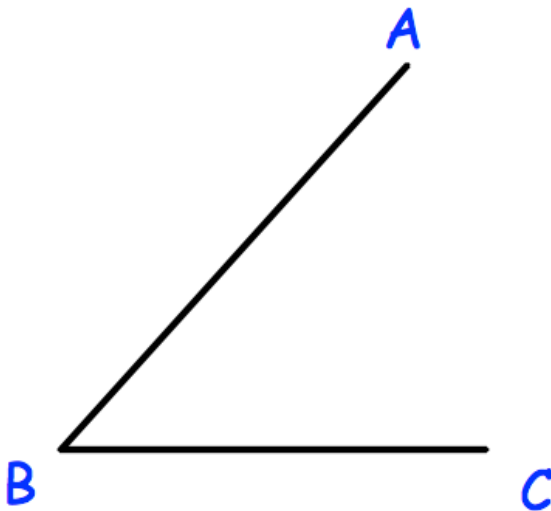

(2)

81. A and B are two points.

A
x

B
x

Shade the region which contains those points which are both closer to A than to B, and less than 5cm from B.

(2)

82.

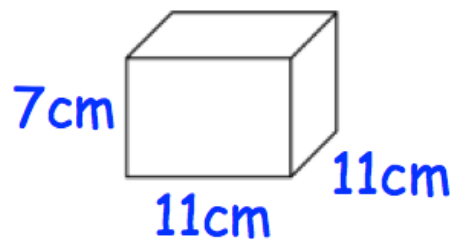

Work out the surface area of this cuboid.
State the units of your answer.

.....
(3)

83. What is the volume of a piece of metal that has a mass of 300g and density of 6g/cm^3 ?

..... cm^3
(2)

84.

Find the pressure exerted by a force of 240 newtons on an area of 30cm^2 .
Give your answer in newtons/ m^2

.....
(3)

85. Shown below is a triangular prism.

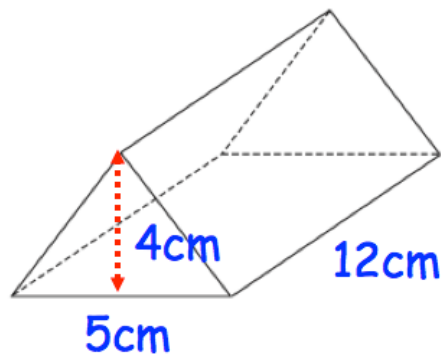

Find the volume of the triangular prism.

..... cm^3
(3)

86. Shown below is a rectangle drawn on a coordinate grid.

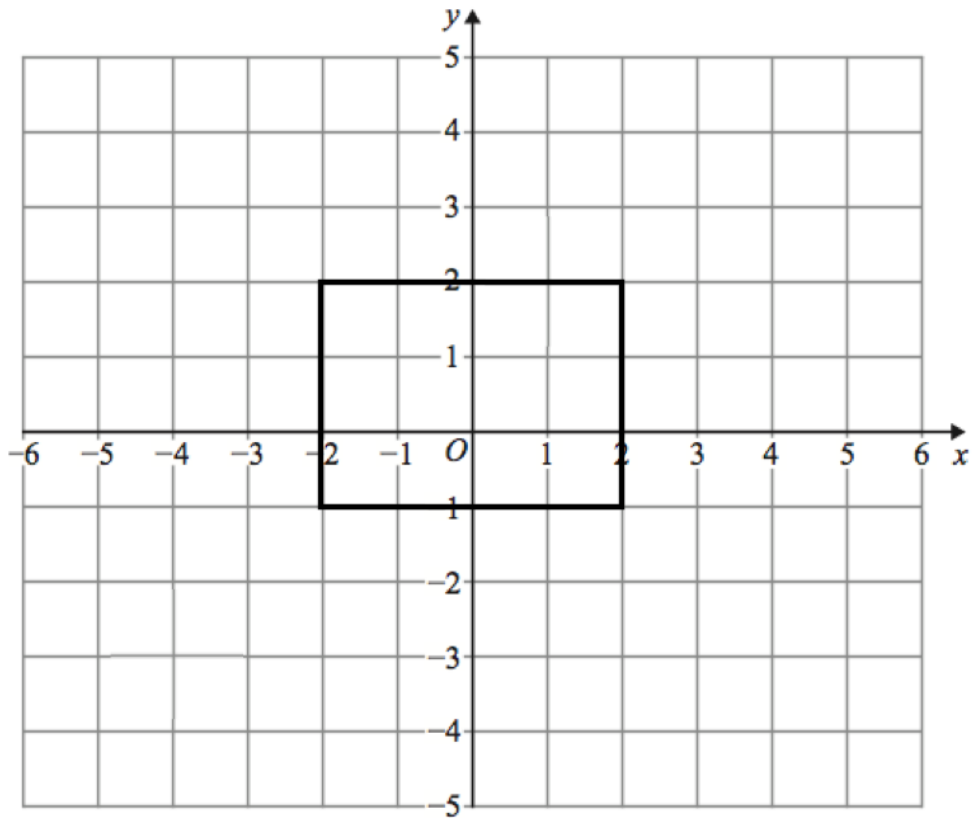

Enlarge the rectangle by scale factor 2, using centre of enlargement $(-1, 0)$.

(3)

87. Shown below is a circle with radius 10cm.

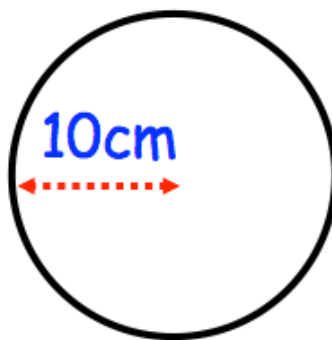

Work out the circumference of the circle.
Give your answer in terms of π .

.....cm
(2)

88. Here are the front elevation and plan view of a solid shape.

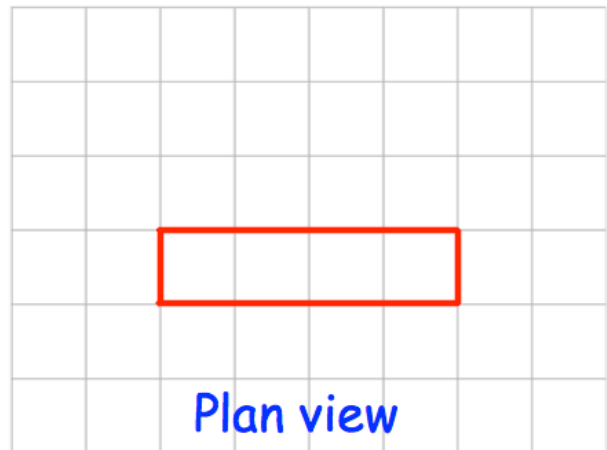
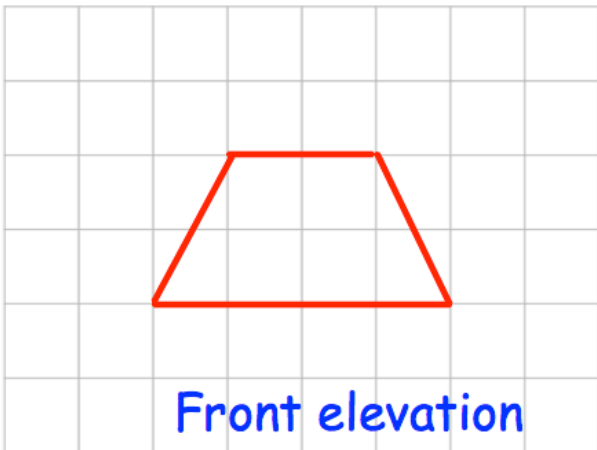

(a) On the grid, draw the side elevation.

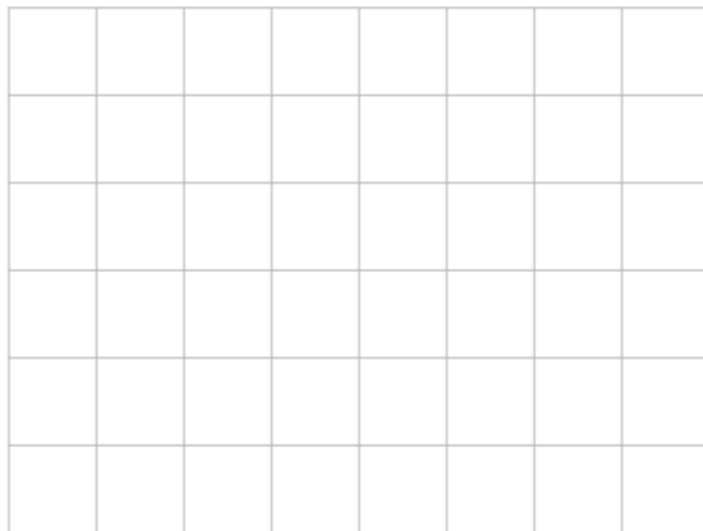

(2)

(b) Draw a sketch of the solid shape.

(2)

89. Shown is the plan of a small field.

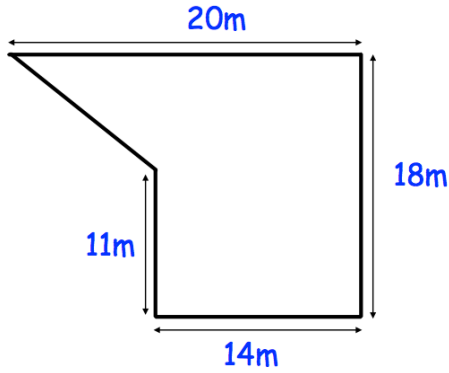

Thomas is going to keep some chickens in the field.
Each chicken needs 5m^2 .

Work out the greatest number of chickens Thomas can keep in the field.

.....
(5)

90. Below is a cylinder with diameter 8cm and height of 10cm.

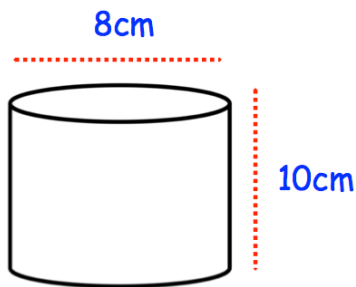

Find the volume of the cylinder.

..... cm^3
(3)

91. The diagram shows a right-angled triangle.

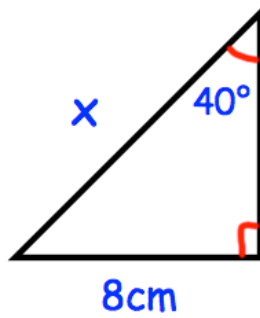

Calculate the length of x .

.....cm
(3)

92. A semi-circle has diameter 20cm .

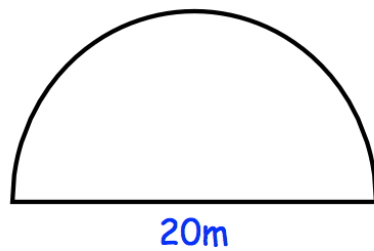

Calculate the perimeter of the semi-circle.

.....m
(2)

93. Shown is a major sector of a circle.

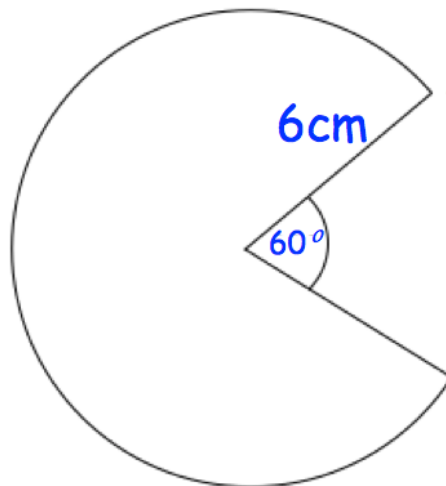

Find the area of the major sector.

.....cm²
(3)

94. Shown is a sphere with radius 6cm.

Surface area of sphere = $4\pi r^2$

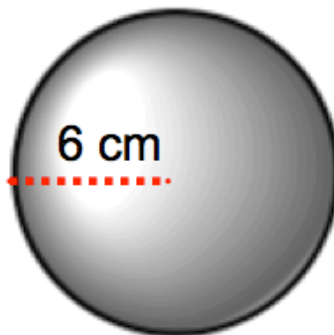
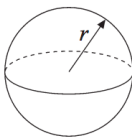

Calculate the surface area of the sphere.

.....cm²
(3)

95. A cone has base diameter 18cm.
The height of the cone is 20cm.
Calculate the volume of the cone.

Volume of cone $= \frac{1}{3} \pi r^2 h$

Curved surface area of cone $= \pi r l$

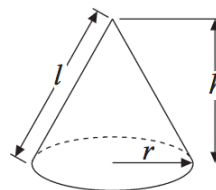

.....cm³
(3)

-
96. Given

$$a = \begin{pmatrix} 6 \\ -4 \end{pmatrix} \quad b = \begin{pmatrix} -2 \\ 1 \end{pmatrix}$$

Work out $2a + b$

.....
(3)

97.

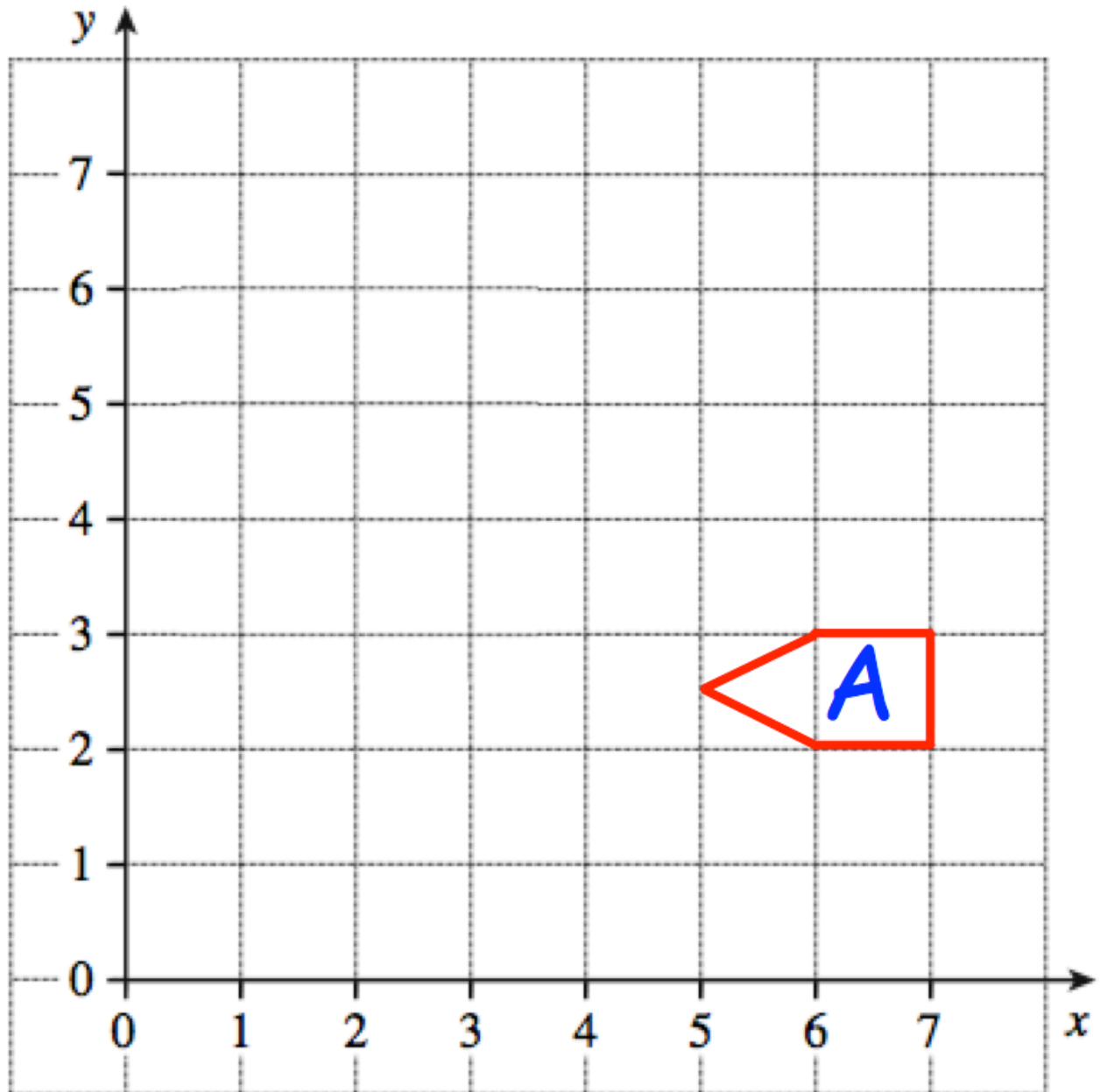

Reflect shape A in the line $x = 4$
Label the new shape B.

(2)

98.

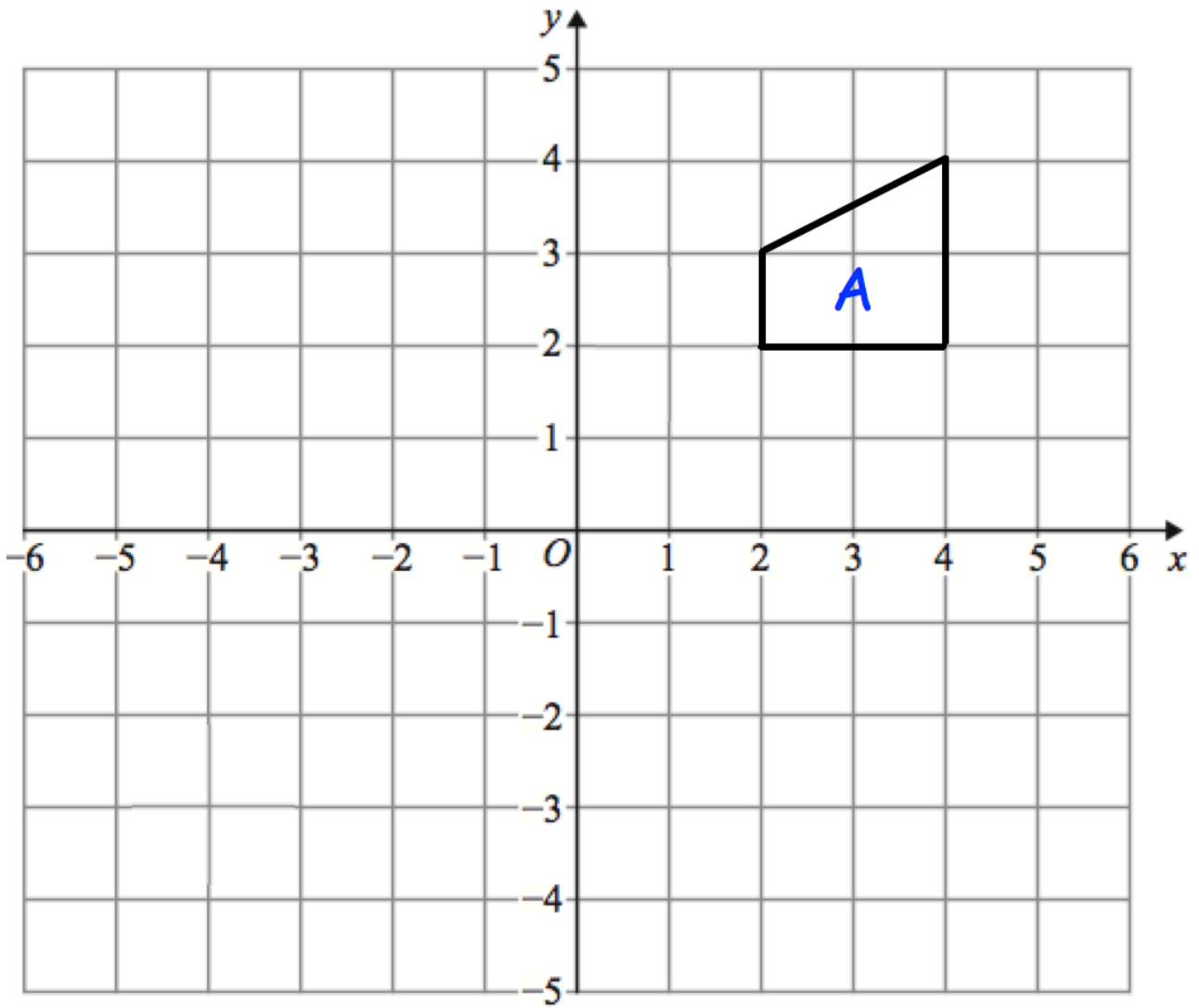

Rotate shape A 180° about centre $(-1, 2)$

(3)

99.

For each pair below, state the condition why they are congruent.

(a)

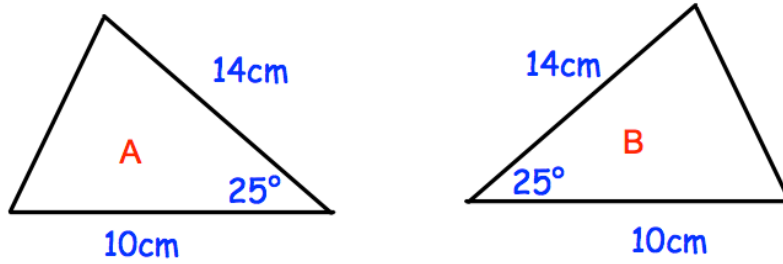

Condition:
(1)

(b)

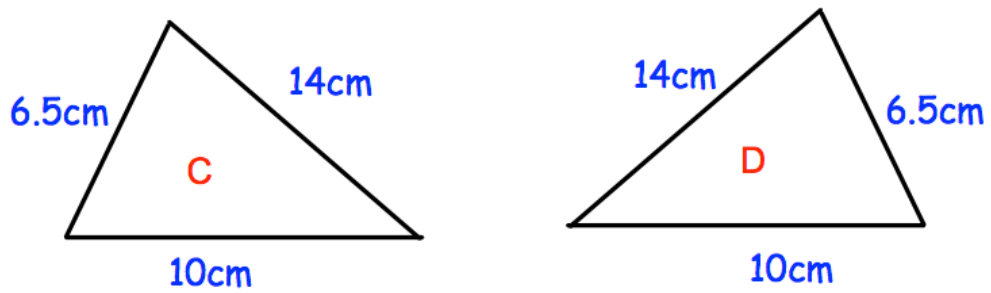

Condition:
(1)

(c)

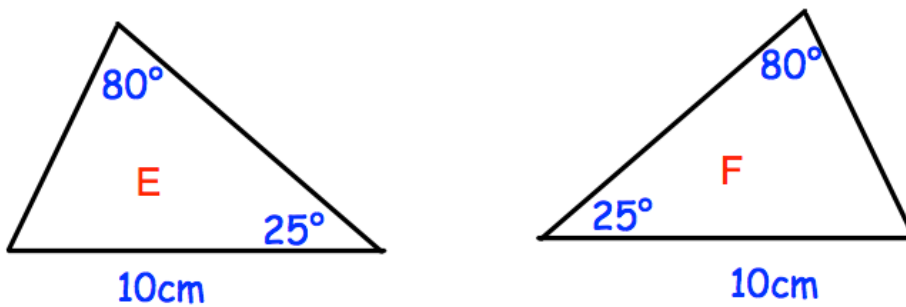

Condition:
(1)

100.

Not drawn accurately

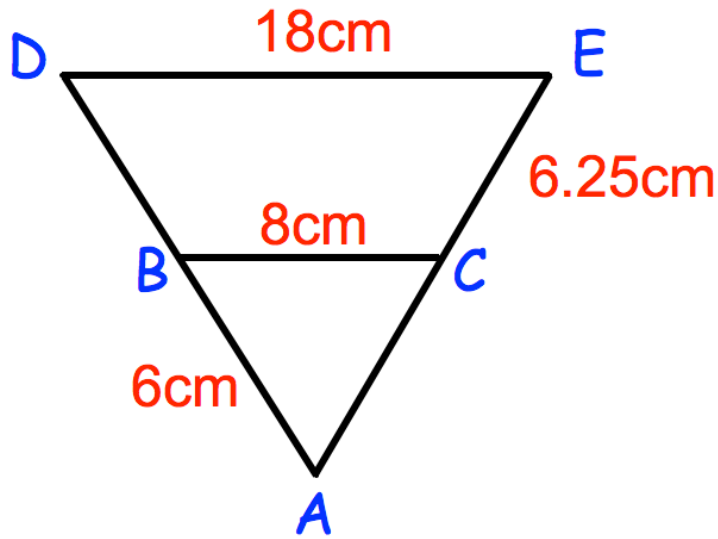

Triangle ABC is similar to triangle ADE .

- $AB = 6\text{cm}$
- $BC = 8\text{cm}$
- $CE = 6.25\text{cm}$
- $DE = 18\text{cm}$

(a) Work out the length of DB .

.....cm
(3)

(b) Work out the length of AC .

.....cm
(3)

101. (a) Complete the table of values for $y = x^2 + x$

x	-3	-2	-1	0	1	2	3
y	6		0		2	6	

(2)

(b) On the grid, draw the graph of $y = x^2 + x$ for the values of x from -3 to 3.

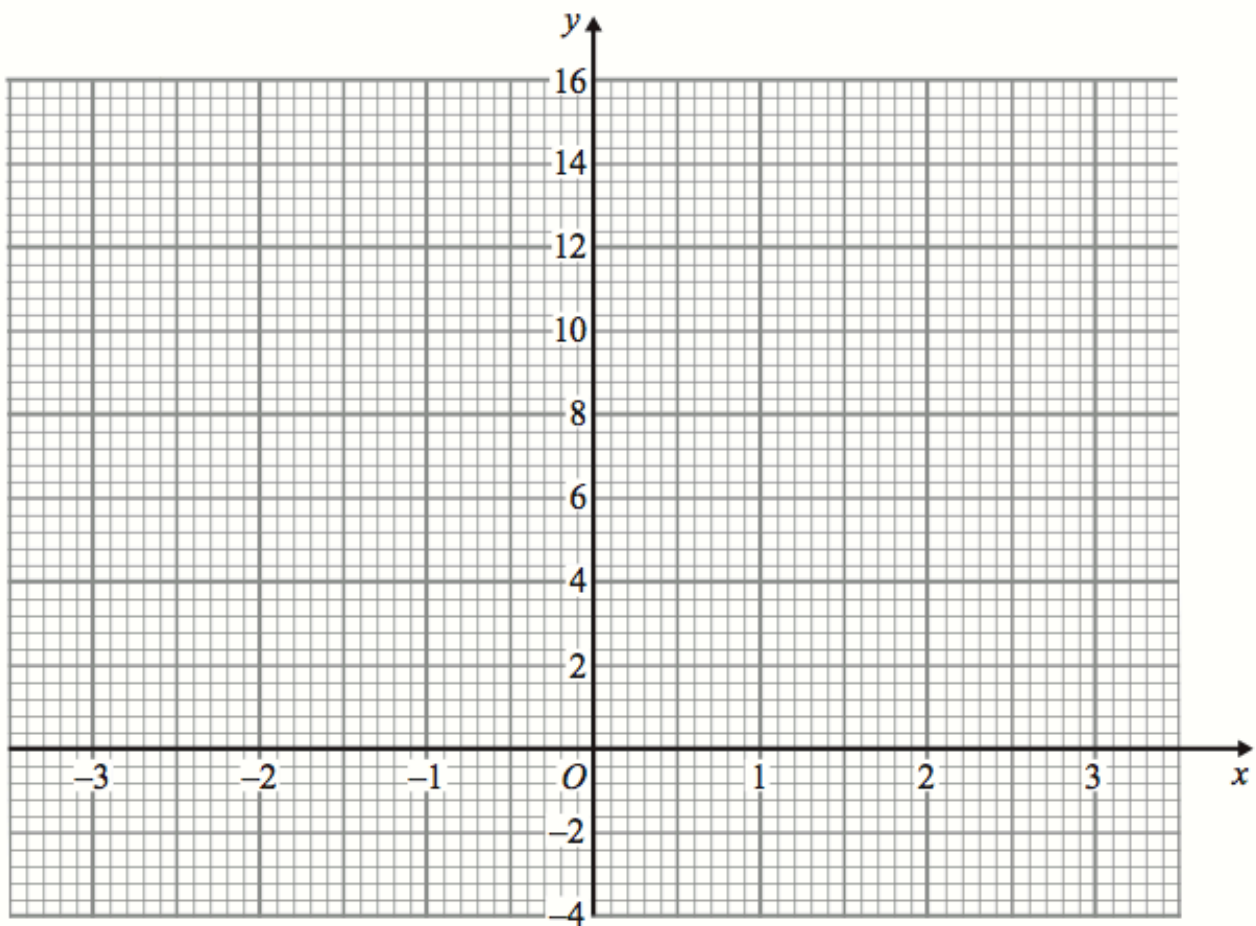

(2)

102. Solve the simultaneous equations

$$\begin{aligned}3x + 5y &= 1 \\2x - 3y &= 7\end{aligned}$$

Do not use trial and improvement

$$x = \dots\dots\dots y = \dots\dots\dots$$

(4)

103.

$$v = u + 10t$$

(a) Work out the value of v when $u = 4$ and $t = 3$

$$v = \dots\dots\dots$$

(2)

(b) Make u the subject of the formula

$$v = u + 10t$$

$$u = \dots\dots\dots$$

(2)

(c) Make t the subject of the formula

$$v = u + 10t$$

$$t = \dots\dots\dots$$

(2)

104. A rectangle is shown below.

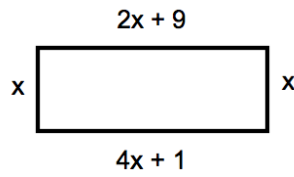

(a) Explain why $4x + 1 = 2x + 9$

.....
.....
(1)

(b) Find the size of x .

$x = \dots\dots\dots$ cm
(2)

(c) Work out the area of the rectangle.

$\dots\dots\dots$ cm²
(2)

105.

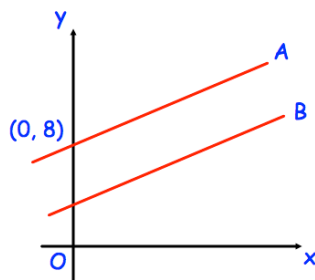

The lines A and B are parallel.

The line A passes through the point (0, 8)

The line B has equation $y = 3x + 1$

Write down the equation of line A

.....
(2)

106. The table gives information about the dogs in a village

Breed	Frequency
Spaniel	11
Poodle	7
Greyhound	4
Jack Russell	14

Draw an accurate pie chart to show this information.

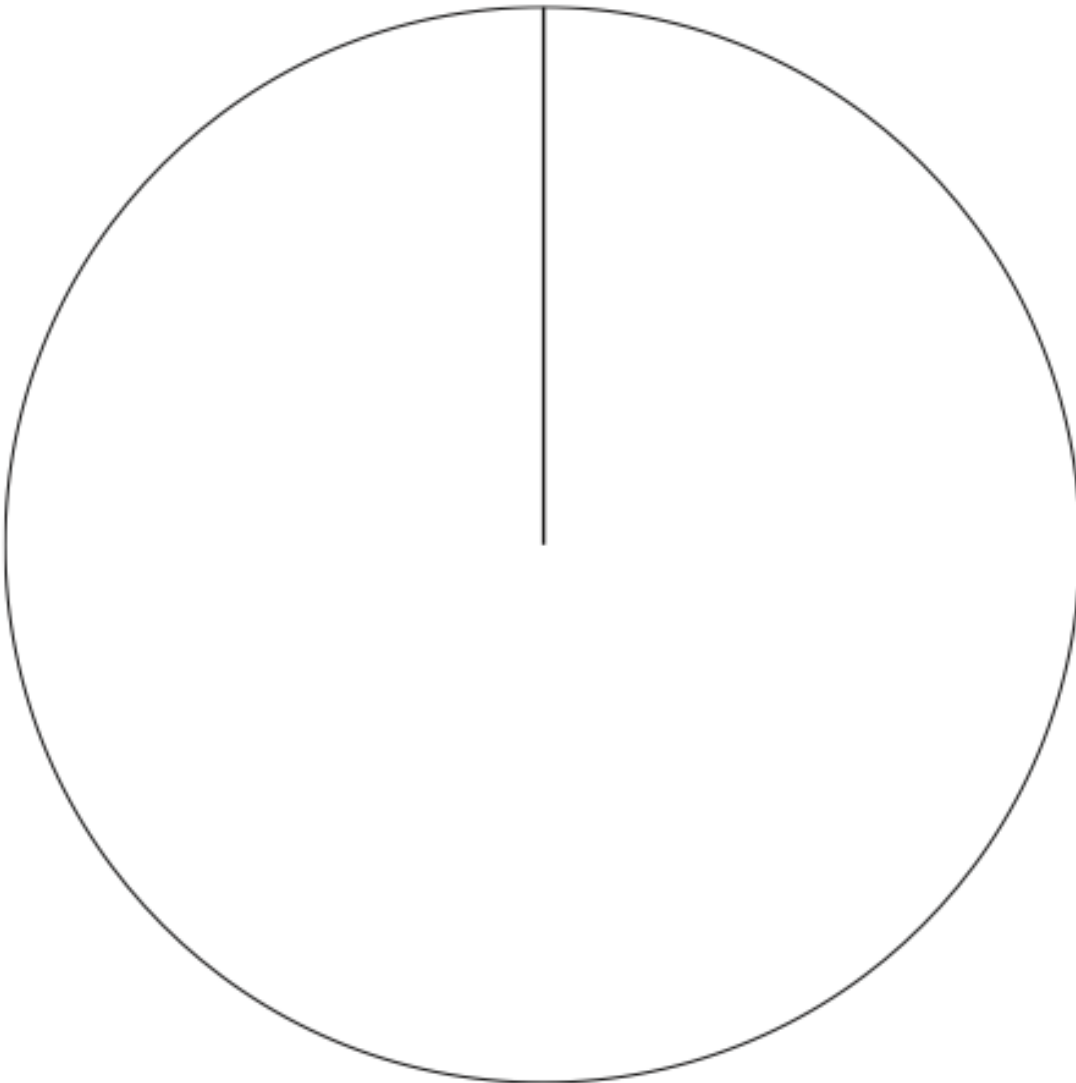

(4)

107. (a) Simplify

$$m^5 \times m^3$$

.....
(1)

(b) Simplify

$$m^8 \div m^2$$

.....
(1)

(c) Simplify

$$(m^3)^2$$

.....
(1)

108. Write down the exact value of $\cos 60^\circ$

.....
(1)

109. Below is rectangle, ABCD

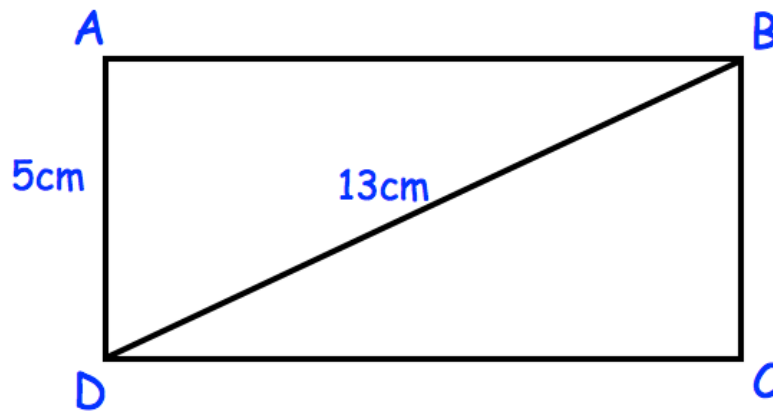

AD = 5cm
BD = 13cm

Calculate the perimeter of rectangle ABCD

.....cm
(3)

110. A circle has an area of 64 cm^2

Work out the radius of the circle.

.....cm
(2)

111. The diagram shows the position of two people, A and B, who are on their Duke of Edinburgh expedition.



The bearing of person C from person A is 062°
 The bearing of person C from person B is 275°

In the space above, mark the position of person C with a cross (x). Label it C.

(3)

112.

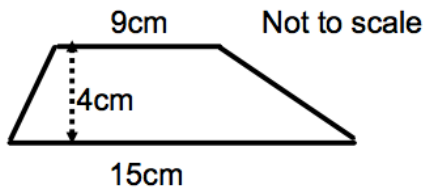

Calculate the area of the trapezium.

..... cm^2
(2)

113. Nigel measures the time, t seconds, to complete a race as 14.8 seconds correct to the nearest tenth of a second.

Write down the error interval for t .

.....
(2)

114. Candles normally cost £6 each.

Two websites have special offers

Corbettmaths Candles

Buy 3 get 1 free

Candles'R'us

20% off

Laura wants to buy 30 candles.
Which website should Laura use?

(4)

115. Calculate the value of

$$\sqrt[3]{(25.4 - 5.9)^2}$$

(a) Write down your full calculator display.

.....
(1)

(b) Give your answer to three significant figures.

.....
(1)

116. Felicity has two boxes of counters, each with an equal ratio of black and white beads.

In box A, 54 of the beads are black and 36 are white.
There are 162 white beads in box B.

How many beads are there in the two boxes in total?

.....
(4)