

Paper 5 and Paper 6 Preparation Paper

OCR Higher



Corbettmaths

Ensure you have: Pencil, pen, ruler, protractor, pair of compasses and eraser

You will also need a calculator.

Guidance

1. Read each question carefully before you begin answering it.
2. Check your answers seem right.
3. Always show your workings

Paper 5 and 6 Checklist

Question	Topic	Video number
See website	Circle Theorems	64, 65
See website	$\frac{1}{2}ab\sin C$	337
See website	Speed, Distance, Time	299
See website	Geometric Proof	366
See website	Pie Charts	163, 164
See website	Box Plots	149
See website	Tree Diagrams	252
See website	Instantaneous rates of Change	390a
See website	Average rates of Change	390b
See website	Area under a Graph	389
See website	Inverse Functions	369
See website	Composite Functions	370
See website	Completing the Square	10, 371
See website	Transformations of Graphs	323, 324

1. Hannah is baking two cakes.



One cake needs $1\frac{1}{3}$ cups of milk. $\frac{4}{3}$

Hannah has $1\frac{1}{4}$ cups of milk. $\frac{5}{4}$

How much more milk does Hannah need?

$$\frac{4}{3} \times \frac{2}{1} = \frac{8}{3}$$

$$\frac{8}{3} - \frac{5}{4}$$

$$\frac{32}{12} - \frac{15}{12} = \frac{17}{12}$$

$1\frac{5}{12}$ cups
(3)

2. The Burton family drink $2\frac{5}{6}$ litres of lemonade a day.



Their local shop sells 3 litres of lemonade for £2.80 or 2 litres for £1.95.

Work out the lowest amount of money that the family can spend in the shop to buy lemonade to last them for one week.

$$2\frac{5}{6} \times 7 = 19\frac{5}{6} \text{ litres per week}$$

$$6 \times 3L @ 1 \times 2L = 20 \text{ Litres}$$

$$\left. \begin{array}{l} 6 \times £2.80 = £16.80 \\ 1 \times £1.95 = £1.95 \end{array} \right\} £18.75$$

$$£ \underline{\quad 18.75 \quad}$$

(4)

3.

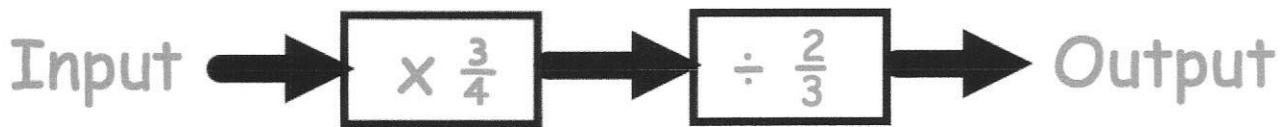

(a) Find the output, if the input is 2.

$$\frac{2}{1} \times \frac{3}{4} = \frac{6}{4} = \frac{3}{2}$$

$$\frac{3}{2} \div \frac{2}{3} \Rightarrow \frac{3}{2} \times \frac{3}{2} = \frac{9}{4}$$

$$\underline{\quad \frac{9}{4} \quad}$$

(3)

(b) Find the input, if the output is $\frac{1}{2}$

$$\frac{1}{2} \times \frac{2}{3} = \frac{2}{6} = \frac{1}{3}$$

$$\frac{1}{3} \div \frac{3}{4}$$

$$\frac{1}{3} \times \frac{4}{3} = \frac{4}{9}$$

$$\underline{\quad \frac{4}{9} \quad}$$

(3)

4. Work out 0.017×0.45



$$\begin{array}{r} 45 \\ \times 17 \\ \hline 315 \\ 450 \\ \hline 765 \end{array}$$

$$\underline{\underline{0.00765}}$$

(2)

5. Estimate the value of



$$\underline{\underline{803 \times 2.97}}$$

$$0.613$$

$$\approx \frac{800 \times 3}{0.6} = \frac{2400}{0.6}$$

$$24000 \div 6$$

$$\underline{\underline{4000}}$$

(3)

6. James has received two job offers.

A job in Milan which pays €55,000 a year.

A job in Boston which pays \$64,000 a year.

The exchange rates were £1 = \$1.42 and £1 = €1.25.

Which job offer has the highest salary?

Show working to explain your answer.

$$\text{Milan } 55000 \div 1.25 = \pounds 44000$$

$$\text{Boston } 64000 \div 1.42 = \pounds 45070.42$$

Boston

(3)

7. Find the Lowest Common Multiple (LCM) of 60 and 72.

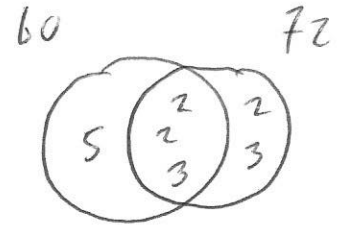
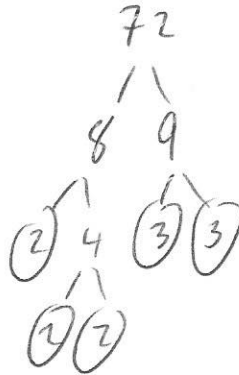
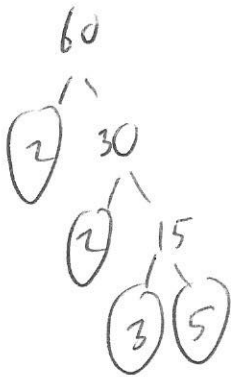

$$60 = 2 \times 2 \times 3 \times 5$$

$$72 = 2 \times 2 \times 2 \times 3 \times 3$$

$$\text{LCM} = 5 \times 2 \times 2 \times 3 \times 2 \times 3$$

$$= 360$$

360

(2)

8. (a) Express 108 as a product of its prime factors. Give your answer in index form.

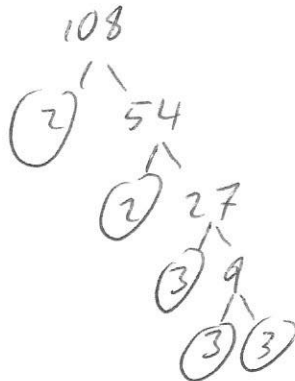

$$2^2 \times 3^3$$

(3)

(b) Find the Highest Common Factor (HCF) of 108 and 72.

$$72 = 2^3 \times 3^2$$

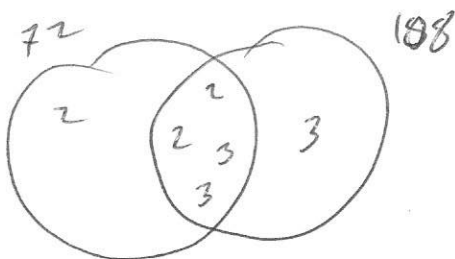

$$\text{HCF} = 2 \times 2 \times 3 \times 3$$

36

(2)

9. (a) Work out $36^{\frac{1}{2}}$



$$\sqrt{36}$$

$$\begin{array}{r} 6 \\ \hline \end{array} \quad (2)$$

(b) Work out $125^{\frac{2}{3}}$

$$\sqrt[3]{125} = 5$$

$$5^2 = 25$$

$$\begin{array}{r} 25 \\ \hline \end{array} \quad (2)$$

10. (a) Write 5930000000 in standard form.

$$\begin{array}{r} 5.93 \times 10^9 \\ \hline \end{array} \quad (1)$$

(b) Write 8.024×10^{-4} as an ordinary number.

$$\begin{array}{r} 0.0008024 \\ \hline \end{array} \quad (1)$$

(c) $c = 2 \times 10^6$ and $y = 6 \times 10^5$

$$w^2 = \frac{cy}{c-y}$$

$$w^2 = \frac{12 \times 10^{11}}{1400000} = 857142.8571$$

$$w = 925.82 \dots$$

Work out the value of w .

Give your answer in standard form correct to 2 significant figures.

$$\begin{array}{r} 930 \\ \hline \end{array} \quad (3)$$

11. Harriet travelled from Bath to Cardiff.
Her average speed was 58 miles per hour.

There is traffic on the return journey.
Her average speed is reduced by 23%

Work out the average speed on the return journey.

$$0.58 \times 0.77$$

$$\begin{array}{r} 44.66 \\ \hline \end{array} \text{mph} \\ (3)$$

-
12. Nina invested £1500 for 4 years at 2.5% per annum simple interest.

Work out the total amount of money in the account at the end of 4 years.

$$1500 \times 0.025 = £37.50$$

$$£37.50 \times 4 = £150$$

$$£1500 + £150 = £1650$$

$$\begin{array}{r} £ 1650 \\ \hline \end{array} \\ (3)$$

13. Martyn has some money to invest and sees this advert.

Bank of Maths

Double your money in 15 years.

The average annual growth for your investment is 4.5%

Will Martyn double his money in 15 years by investing his money with "Bank of Maths?"

You **must** show your workings.

Let Martyn have £100

$$100 \times 1.045^{15} = £193.53$$

No, he will not double his money in 15 years

(4)

14. In a sale the price of a sofa is reduced by 70%.
The sale price is £255

Work out the price before the sale.

$$30\% \rightarrow 255$$

$$1\% \rightarrow 8.5$$

$$100\% \rightarrow 850$$

£ 850

(3)

15. Show algebraically that $0.3\dot{0}9$ can be written as $\frac{17}{55}$

$$x = 0.3090909\dots$$

$$10x = 3.0909\dots$$

$$1000x = 309.0909\dots$$

$$990x = 306$$

$$x = \frac{306}{990} = \frac{17}{55}$$

(3)

16. A is the point with coordinates (3, 20)
 B is the point with coordinates (15, 2)
 N is a point of the line AB such that AN : NB = 2 : 1

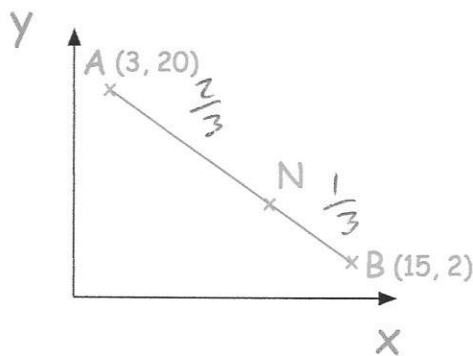

Find the coordinates of the point N.

$$15 - 3 = 12$$

$$\frac{2}{3} \text{ of } 12 = 8$$

$$x \text{ coordinate is } 3 + 8 = 11$$

y coordinate

$$2 - 20 = -18$$

$$\frac{2}{3} \text{ of } -18 = -12$$

$$20 - 12 = 8$$

(11, 8)

(3)

17. The time taken, t , for passengers to be checked-in for a flight is inversely proportional to the square of the number of staff, s , working.

It takes 30 minutes passengers to be checked-in when 10 staff are working.

(a) Find an equation connecting t and s .

$$t \propto \frac{1}{s^2} \quad k = 3000$$

$$t = \frac{k}{s^2} \quad t = \frac{3000}{s^2}$$

$$30 = \frac{k}{10^2}$$

$$\frac{t = \frac{3000}{s^2}}{\dots\dots\dots} \quad (3)$$

(b) What is the minimum number of staff that must be working so that the time taken is under 60 minutes?

$$60 = \frac{3000}{s^2}$$

$$s^2 = 50$$

$$s = 7.07\dots$$

$$\frac{8}{\dots\dots\dots} \quad (3)$$

18. (a) Evaluate $\sqrt{2} \times \sqrt{32}$

$$\sqrt{64}$$

$$\frac{8}{\dots\dots\dots} \quad (2)$$

(b) Expand and simplify $(\sqrt{3} + \sqrt{5})^2$

$$(\sqrt{3} + \sqrt{5})(\sqrt{3} + \sqrt{5}) = 3 + \sqrt{15} + \sqrt{15} + 5$$

$$\frac{8 + 2\sqrt{15}}{\dots\dots\dots} \quad (2)$$

(c) Evaluate $(5 + \sqrt{2})(5 - \sqrt{2})$

$$25 - \cancel{5\sqrt{2}} + \cancel{5\sqrt{2}} - 2$$

$$\frac{23}{\dots\dots\dots} \quad (2)$$

19. Ethan picks a 5-digit even number.

The first digit is odd

The second digit is prime

The fourth digit is a factor of 21

1, 3, 7, 21

How many different 5-digit numbers could he pick?

1st 2nd 3rd 4th 5th
1, 3, 5, 7, 9 3, 3, 5, 7 1, 3, 7 0, 2, 4, 6, 8

$$5 \times 4 \times 10 \times 3 \times 5$$

3000

(2)

20. Nigel measures the time, t seconds, to complete a race as 15.4 seconds correct to the nearest tenth of a second.

Write down the error interval for t .

$$15.35 \leq t < 15.45$$

(2)

21. Expand and simplify $(x - 6)(x + 1)(x - 2)$

$$(x - 6)(x + 1) = x^2 - 5x - 6$$

$$(x^2 - 5x - 6)(x - 2) = x^3 - 2x^2 - 5x^2 + 10x - 6x + 12$$

$$x^3 - 7x^2 + 4x + 12$$

(4)

22. Solve

$$\frac{1}{x+3} - \frac{1}{x+1} = 2$$

$$\frac{x+1 - (x+3)}{(x+3)(x+1)} = 2$$

$$x^2 + 4x + 4 = 0$$

$$(x+2)(x+2) = 0$$

$$\frac{-2}{(x+3)(x+1)} = 2$$

$$-2 = 2(x^2 + 4x + 3)$$

$$x = -2$$

$$x^2 + 4x + 3 = -1$$

(5)

23. The first five terms in a sequence are 10, 17, 24, 31, 38 ...

Write down the nth term of the sequence.

	10	17	24	31
$7n$	7	14	21	28

$$7n + 3$$

(2)

24. Here are the first 5 terms of a quadratic sequence

9 17 29 45 65

Find an expression, in terms of n, for the nth term of this quadratic sequence.

~~17~~ ~~17~~

9	17	29	45	65
8	12	16	20	
4	4	4		

$$2a = 4$$

$$a = 2$$

$$3a + b = 8$$

$$6 + b = 8$$

$$b = 2$$

$$a + b + c = 9$$

$$c = 5$$

$$\frac{2n^2 + 2n + 5}{(3)}$$

25. $v = u + at$

Work out a when $v = 62$, $u = 250$ and $t = 8$

$$62 = 250 + a \times 8$$

$$62 = 250 + 8a$$

$$-188 = 8a$$

$$a = -23.5$$

$$\frac{-188}{8} = -23.5$$

(3)

26. Shown below is an isosceles triangle. Each side is measured in centimetres.

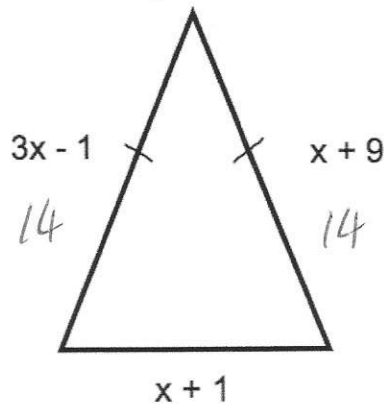

Find the perimeter of the triangle

$$3x - 1 = x + 9$$

$$2x = 10$$

$$x = 5$$

$$14 + 14 + 6 = 34$$

$$34 \text{ cm}$$

(4)

27. Make v the subject of the formula.

$$s = \frac{1}{2}(u + v)t$$

$$v = \frac{2s}{t} - u$$

$$2s = (u + v)t$$

$$\div t \quad \div t$$

$$\frac{2s}{t} = u + v$$

$$v = \frac{2s}{t} - u$$

(3)

28. Solve the inequality $5x + 11 \geq 2$

$$5x \geq -9$$

$$x \geq -1.8$$

$$\underline{x \geq -1.8}$$

(3)

29. The region labelled R satisfies three inequalities.

State the three inequalities

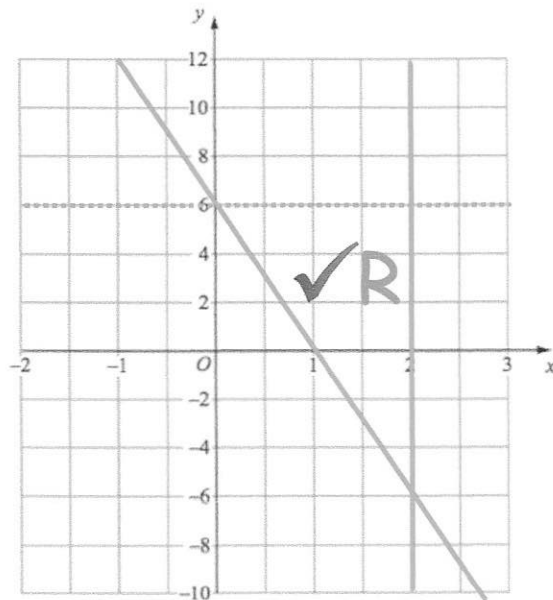

$$\underline{y < 6}$$

$$\underline{x \leq 2}$$

$$\underline{y \geq -6x + 6}$$

(3)

30. Solve the inequality $x^2 - 9x + 14 \leq 0$

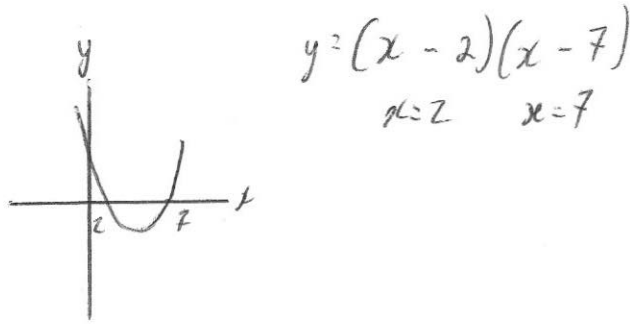

2 ≤ x ≤ 7

(3)

31. On the grid, draw $x + 2y = 6$ for values of x from -2 to 2 .

x	0	1	2
y	3	2.5	2

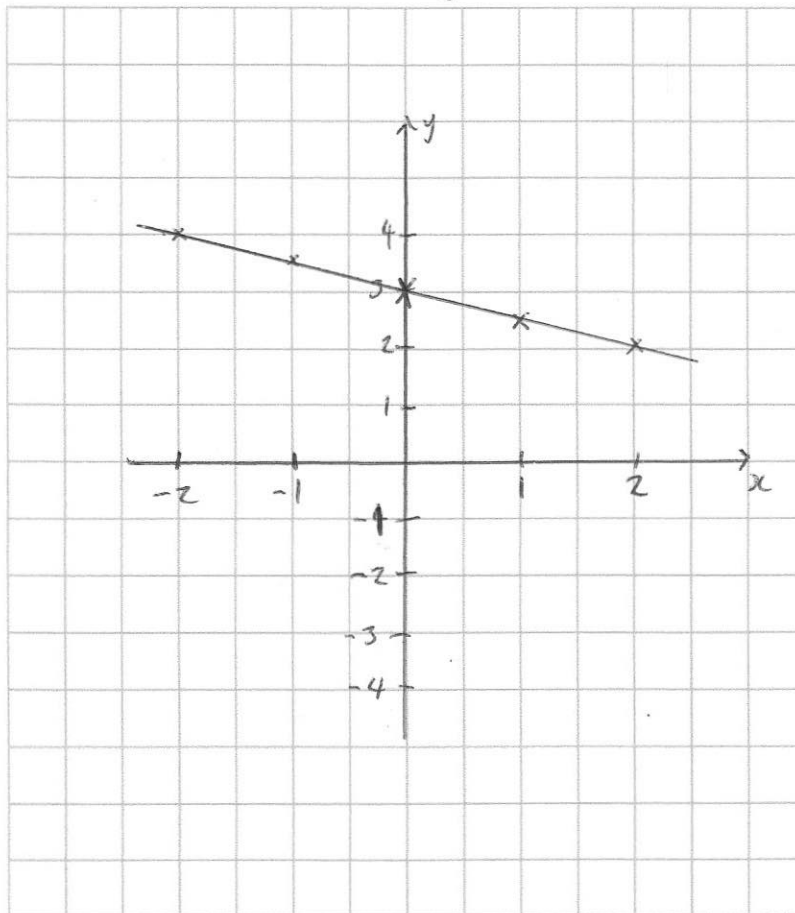

(4)

32

The graph below shows the depth of water in a container.

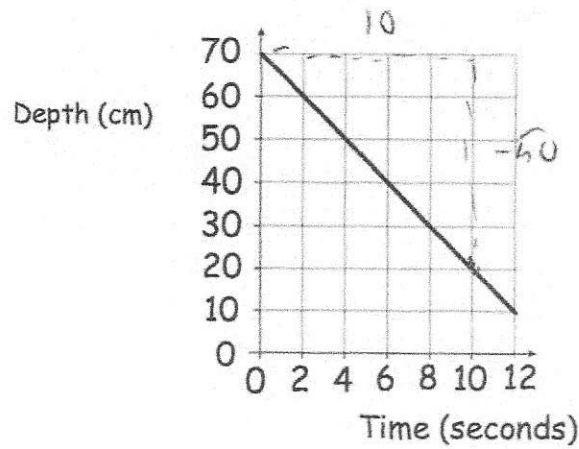

(a) Write down the gradient of the line

$$\frac{-50}{10} = -5$$

-5

(1)

(b) What does the gradient of the line represent?

The change in depth of the water, each second.
Decrease of 5cm per second. (1)

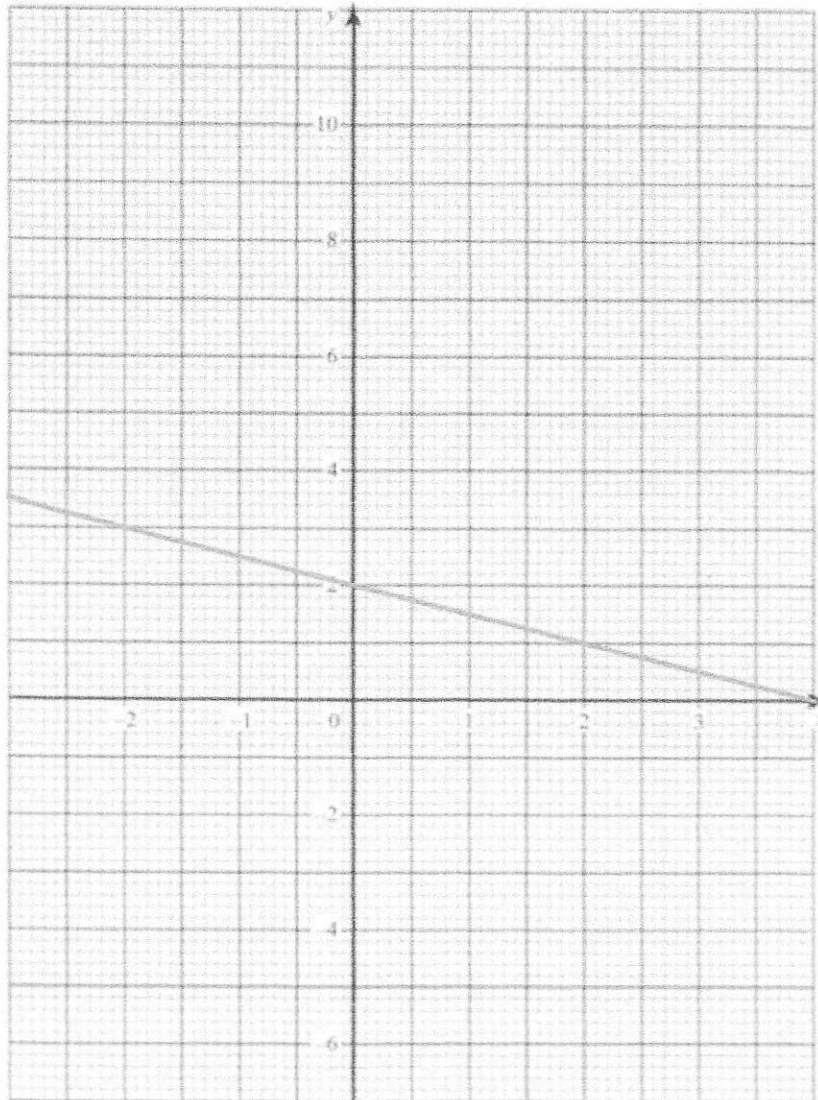

The straight line L has equation $y = -\frac{1}{2}x + 2$

(a) Write down the equation of a line parallel to L

$$\underline{y = -\frac{1}{2}x + 15} \quad (1)$$

(b) Find an equation of the line that goes through the point $(1, 6)$ and is perpendicular to L $m = 2$

$$y = 2x + c$$

$$6 = 2 + c$$

$$c = 4$$

$$\underline{y = 2x + 4} \quad (3)$$

34. Solve the simultaneous equations

$$2x + y = 5$$

$$2x^2 + y^2 = 11$$

$$y = 5 - 2x$$

$$2x^2 + (5 - 2x)(5 - 2x) = 11$$

$$2x^2 + 25 - 10x - 10x + 4x^2 = 11$$

$$6x^2 - 20x + 14 = 0$$

$$3x^2 - 10x + 7 = 0$$

$$(3x - 7)(x - 1) = 0$$

$$x = \frac{7}{3} \quad x = 1$$

$$x = \frac{7}{3}, \quad y = \frac{1}{3}$$

or

$$x = 1, \quad y = 3$$

.....
(4)

35. Draw the circle with equation $x^2 + y^2 = 16$

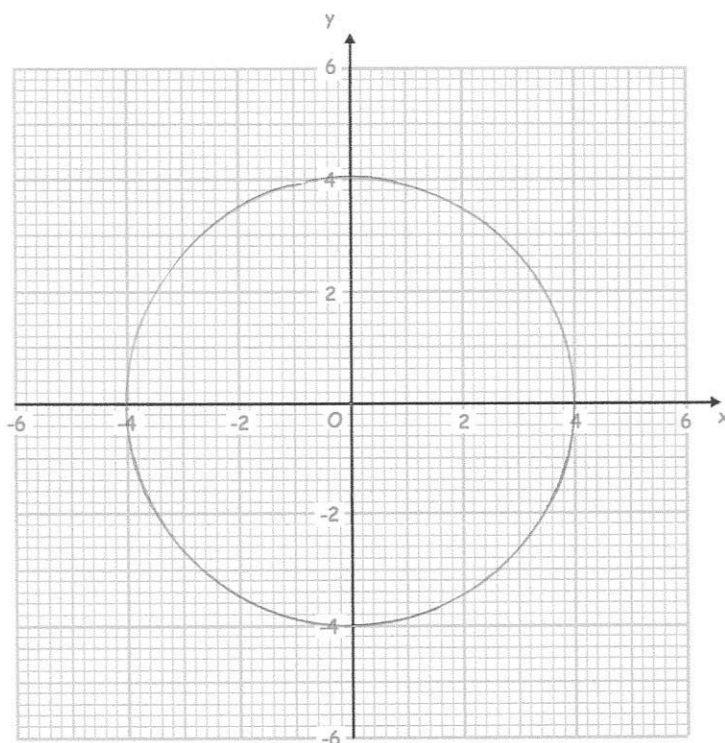

(2)

36. Here is a circle, centre O, and the tangent to the circle at the point (6, 8).

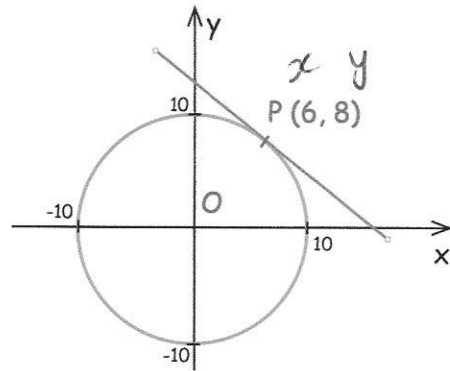

Find the equation of the tangent at the point P.

$$\text{gradient of } OP = \frac{4}{3}$$

$$y = -\frac{3}{4}x + c$$

$$8 = -4.5 + c$$

$$c = 12.5$$

$$y = -\frac{3}{4}x + \frac{25}{2}$$

or

$$y = -0.75x + 12.5$$

(4)

37. Here is the graph of $y = \cos x$

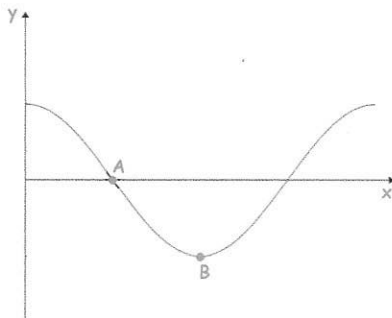

- (a) Write down the coordinates of the point A.

$$\left(\overset{90}{\dots\dots\dots}, \overset{0}{\dots\dots\dots} \right)$$

(1)

- (b) Write down the coordinates of the point B.

$$\left(\overset{180}{\dots\dots\dots}, \overset{-1}{\dots\dots\dots} \right)$$

(1)

38

(a) Complete the table of values for $y = x^3 - 2x + 3$

x	-2	-1	0	1	2
y	-1	4	3	2	7

(2)

(b) On the grid, draw the graph of $y = x^3 - 2x + 3$ for the values of x $-2 \leq x \leq 2$

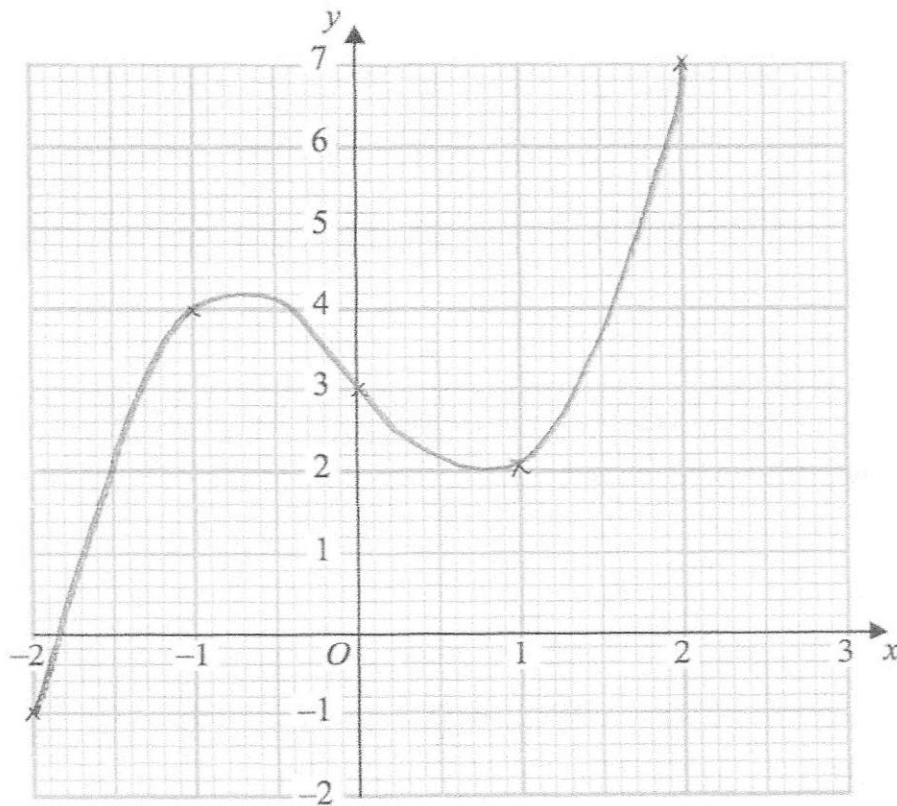

(2)

39

(a) Complete the table of value for $y = \frac{4}{x}$

x	0.5	1	2	4	8	10
y	8	4	2	1	0.5	0.4

(2)

(b) On the grid, draw the graph of $y = \frac{4}{x}$ for $0.25 \leq x \leq 10$

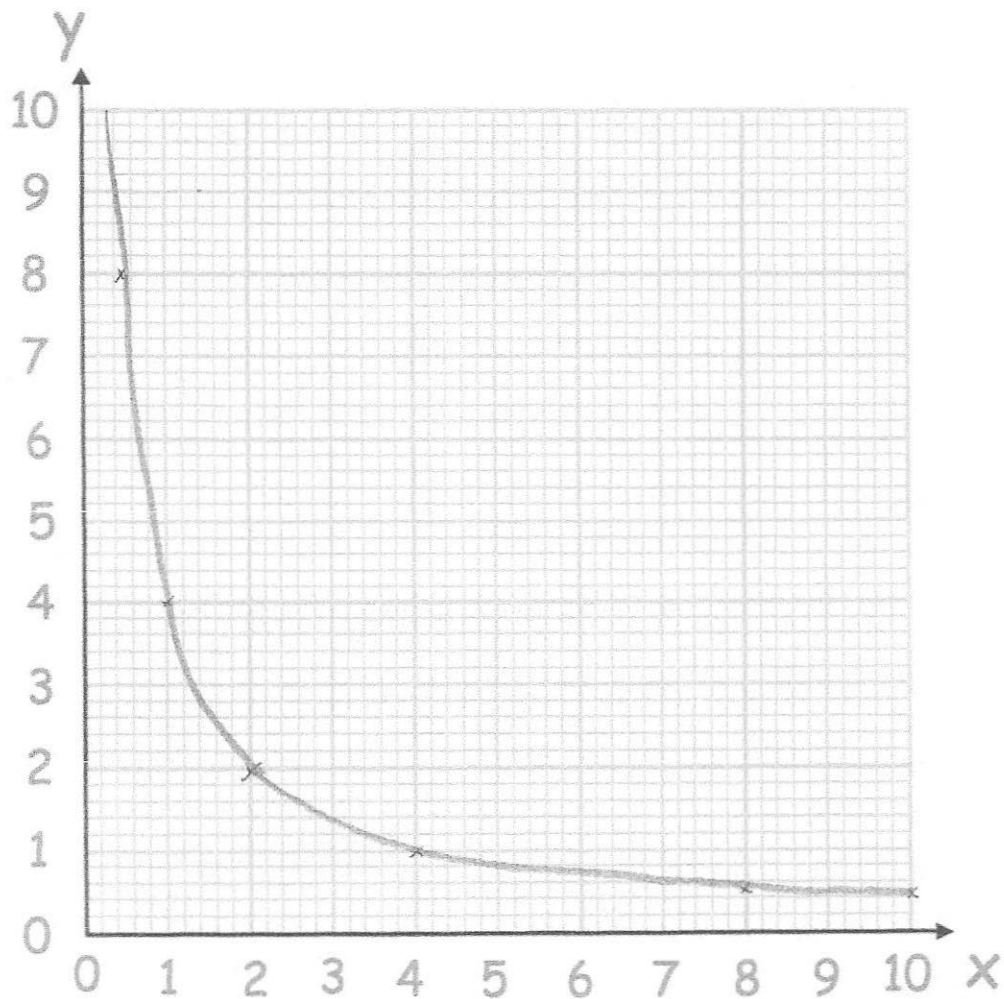

(2)

40

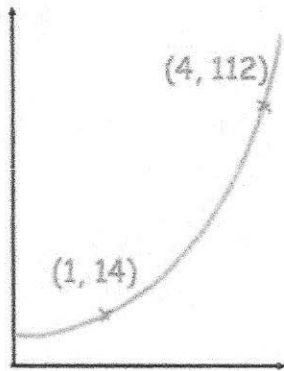

The sketch shows a curve with equation $y = ab^x$ where a and b are constants and $b > 0$

The curve passes through the points $(1, 14)$ and $(4, 112)$

Calculate the value of a and b

$$y = ab^{2x}$$

$$(1, 14) \quad 14 = ab^1 - \textcircled{1}$$

$$14 = ab$$

$$(4, 112) \quad 112 = ab^4 - \textcircled{2}$$

$$\textcircled{2} \div \textcircled{1} = \frac{112}{14} = \frac{ab^4}{ab}$$

$$b^3 = 8$$

$$b = 2$$

$$14 = 2a$$

$$a = 7$$

$$a = 7 \dots\dots\dots$$

$$b = 2 \dots\dots\dots$$

(3)

41

S is a geometric sequence.

27 9 3

The first three terms of S are $(x + 18)$, x and $(2x - 15)$, where x is positive.Find the value of x .

$$\frac{x}{x+18} = \frac{2x-15}{x}$$

$$0 = x^2 + 21x - 270$$

$$0 = (x + 30)(x - 9)$$

$$x = 9$$

$$x^2 = (2x-15)(x+18)$$

$$x^2 = 2x^2 + 21x - 270$$

9

(3)

42

Prove $(2n + 9)^2 - (2n + 5)^2$ is always a multiple of 4

$$(2n+9)(2n+9) - (2n+5)(2n+5) = 4n^2 + 36n + 81 - 4n^2 - 20n - 25$$

$$= 16n + 56$$

$$= 4(4n + 14)$$

\therefore multiple of 4

(4)

43

Solve the equation $x^2 - 2x - 9 = 0$

Give your answers to two decimal places.

$$a = 1 \quad b = -2 \quad c = -9$$

$$x = \frac{2 \pm \sqrt{(-2)^2 - (4 \times 1 \times -9)}}{2}$$

$$x = \frac{2 \pm \sqrt{40}}{2}$$

$$x = 4.16 \quad \text{or} \quad x = -2.16$$

(3)

- (a) Show that the equation $x^3 + 2x = 1$ has a solution between $x = 0$ and $x = 1$

$$x^3 + 2x - 1 = 0$$

$$x = 0 \quad 0^3 + 0 - 1 = -1$$

$$x = 1 \quad 1^3 + 2(1) - 1 = 2$$

As there is a change of sign, there is a solution between 0 and 1 (2)

- (b) Show that the equation $x^3 + 2x = 1$ can be rearranged to give $x = \frac{1}{2} - \frac{x^3}{2}$

$$2x = 1 - x^3$$

$$x = \frac{1}{2} - \frac{x^3}{2}$$

(1)

- (c) Starting with $x_0 = 0$, use the iteration formula $x_{n+1} = \frac{1}{2} - \frac{x_n^3}{2}$ twice to find an estimate for the solution of $x^3 + 2x = 1$

$$x_1 = \frac{1}{2} - \frac{0^3}{2} = 0.5$$

$$x_2 = \frac{1}{2} - \frac{0.5^3}{2} = 0.4375$$

(3)

45. The diagram shows the position of two airplanes, P and Q.

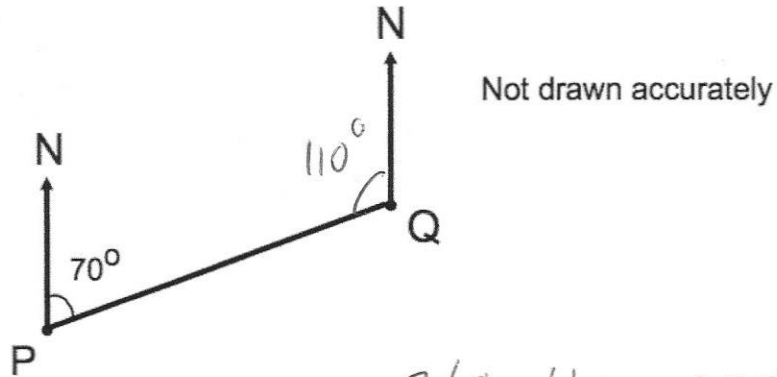

The bearing of Q from P is 070° .

Calculate the bearing of P from

$$360 - 110 = 250^\circ$$

.....⁰
(2)

-
46. Using ruler and compasses, construct the bisector of angle ABC.

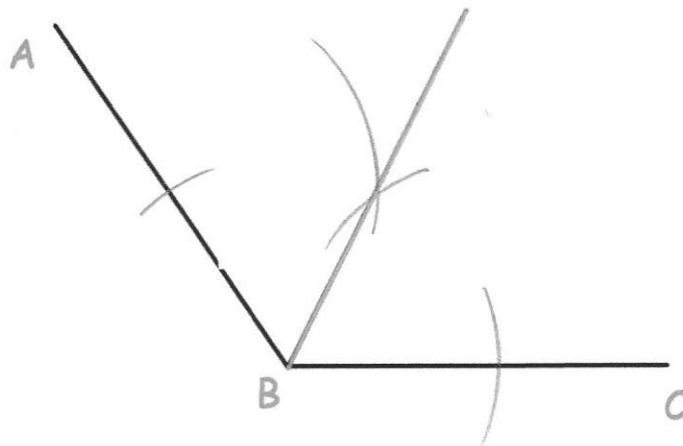

(2)

47. The diagram shows two lighthouses.
A boat is within than 8 miles of lighthouse A.
The same boat is within 6 miles of lighthouse B.
Shade the possible area in which the boat could be.

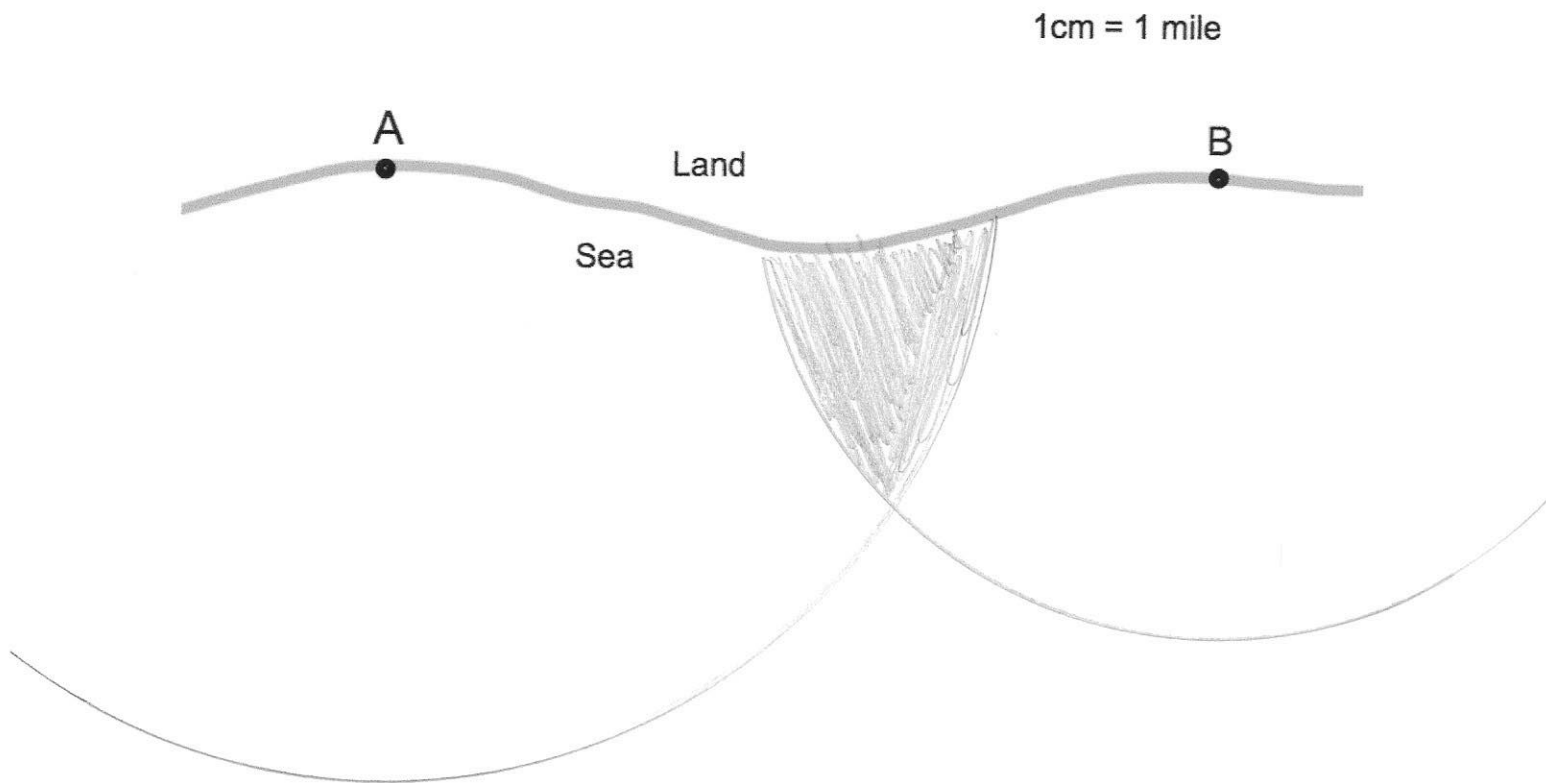

(2)

48. The front elevation of a solid shape is a circle.
The side elevation of the solid shape is a rectangle.
The plan view of the solid shape is a rectangle.

Write down the name of the shape.

Cylinder

(1)

49.

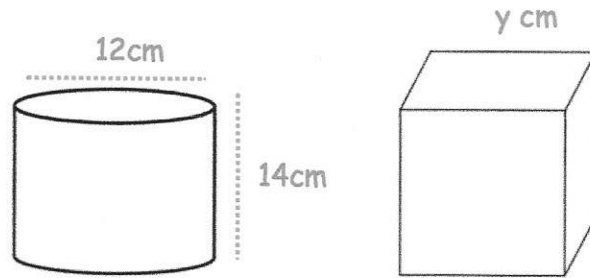

A cylinder has diameter 12cm and height 14cm.

A cube has side length y cm.

The cylinder and cube has the same volume.

Find y.

$$\begin{aligned}
 \text{Cylinder: } V &= \pi r^2 h \\
 &= \pi \times 6^2 \times 14 \\
 &= 1583.36269\dots \text{ cm}^3
 \end{aligned}$$

$$\text{Cube } y \times y \times y = 1583.36\dots$$

$$\sqrt[3]{1583.36\dots}$$

11.66

..... cm
(4)

50. Below are two triangles, ABC and BCD.

$$6^2 + 7^2 = BC^2$$

$$BC^2 = 85$$

$$BC = 9.219\dots$$

$$(\sqrt{85})^2 + 11^2 = BD^2$$

$$BD = \sqrt{206}$$

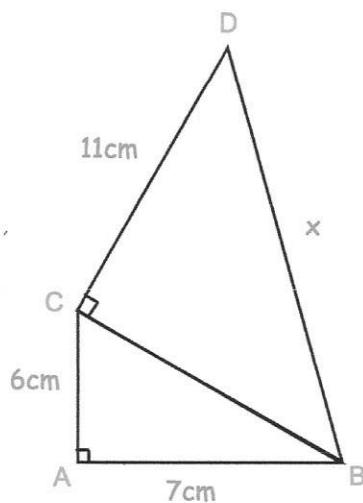

Find x

14.35

..... cm
(4)

51. The diagram shows two right-angled triangles.

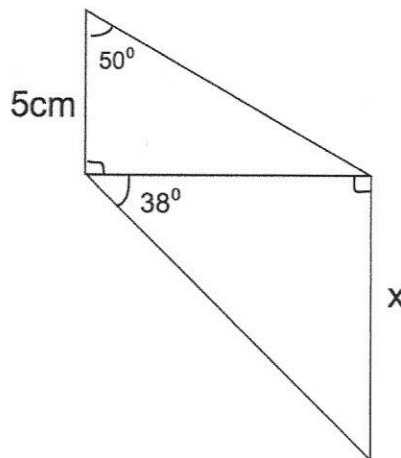

Calculate the value of x .

$$y = \tan(50) \times 5 = 5.9587$$

$$x = \tan(38) \times 5.9587$$

$$\underline{\underline{4.655}} \text{ cm}$$

(5)

52. Shown below is a right angled triangle.

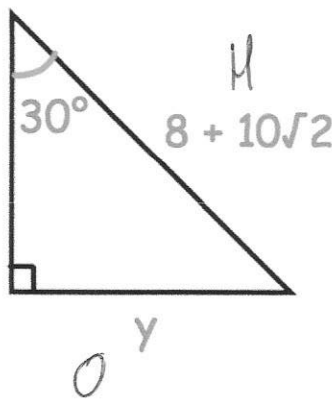

Find the exact length of the side labelled y .

$$\sin(30) \times (8 + 10\sqrt{2})$$

$$\underline{\underline{4 + 5\sqrt{2}}}$$

(4)

53. Shown below is a triangular prism.

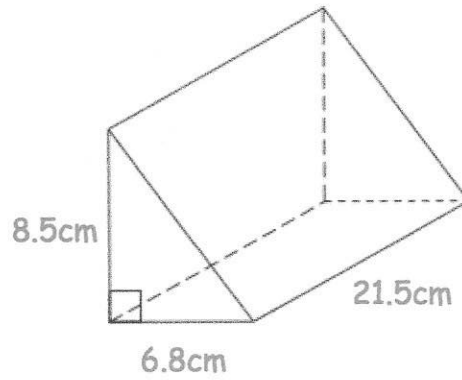

Find the volume of the triangular prism.

$$V = \frac{1}{2} \times (6.8) \times (8.5) \times (21.5)$$

$$= 621.35 \text{ cm}^3$$

..... 621.35 cm^3
(3)

54. Shown is a cone and a triangular prism.

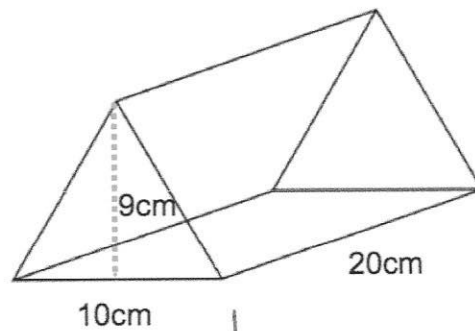
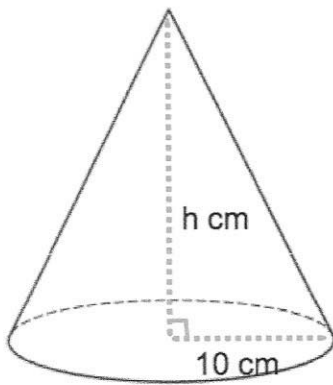

Both solids have the same volume.

Calculate the height of the cone.

↓

$$\frac{1}{2} (10)(9)(20)$$

$$= 900 \text{ cm}^3$$

$$900 = \frac{1}{3} \pi (10)^2 h$$

$$2700 = \pi (100) h$$

$$h = 8.59 \dots$$

..... 8.6 cm
(3)

55.

A cone below has base radius 10cm and height h cm.
A smaller cone radius 4cm and height 6cm is cut from the top.
The frustum is shown below.

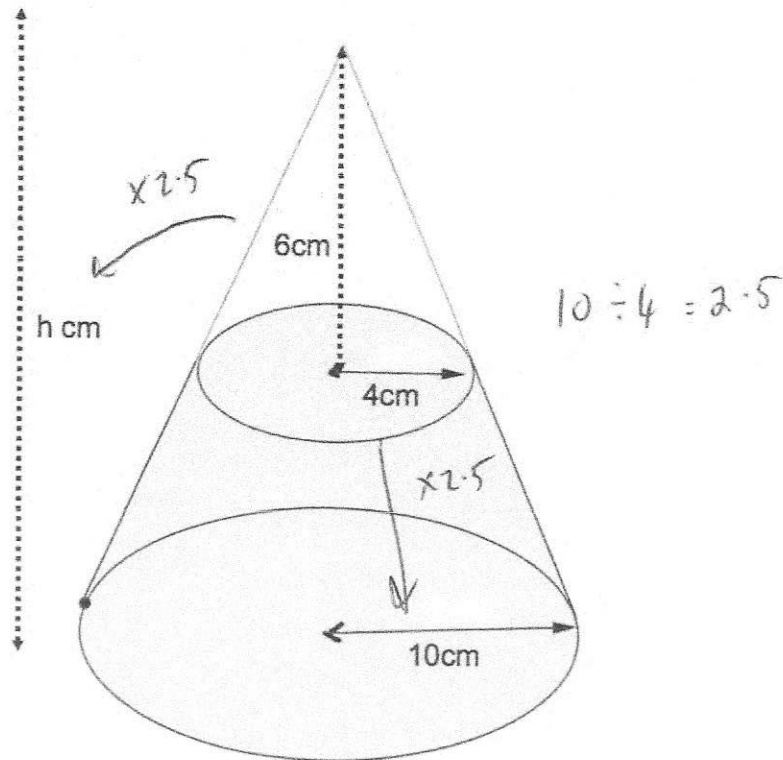

Calculate the volume of the frustum.

$$\text{large cone } \frac{1}{3} \pi \times 10^2 \times 15 = 500 \pi$$

$$\text{small cone } \frac{1}{3} \times \pi \times 4^2 \times 6 = 32 \pi$$

$$500 \pi - 32 \pi = 1470.265 \dots$$

$$\underline{\underline{1470.3}} \text{ cm}^3$$

(5)

56.

A cube has a volume of 343 cm^3

Work out the surface area of the cube.

$$\sqrt{343} = 7$$

$$7 \times 7 = 49$$

$$6 \times 49 = 294$$

$$\underline{\underline{294}} \text{ cm}^2$$

(2)

57. A sphere has a radius of 5cm.

Calculate the surface area of the sphere.

$$4 \times \pi \times 5^2 = 100\pi$$

$$\underline{\underline{314.16 \text{ cm}^2}}$$

(3)

58.

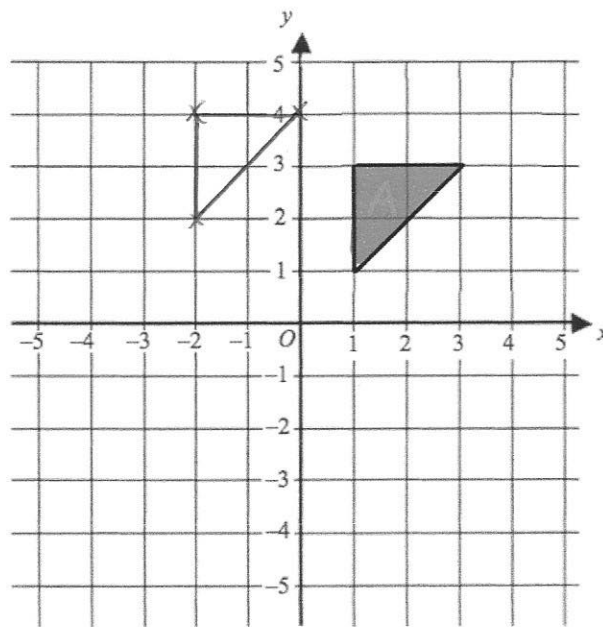

Translate triangle A by the vector $\begin{pmatrix} -3 \\ 1 \end{pmatrix}$

(2)

59

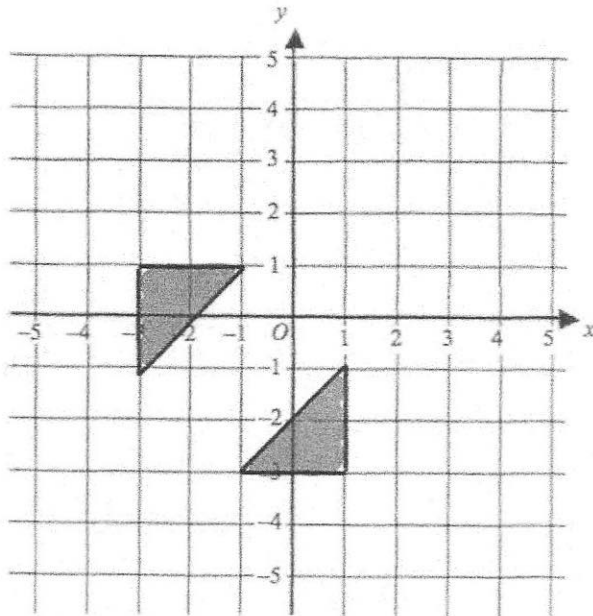

Describe fully the single transformation that maps triangle A onto triangle B.

..... Reflection in the line $y = x$

(2)

60

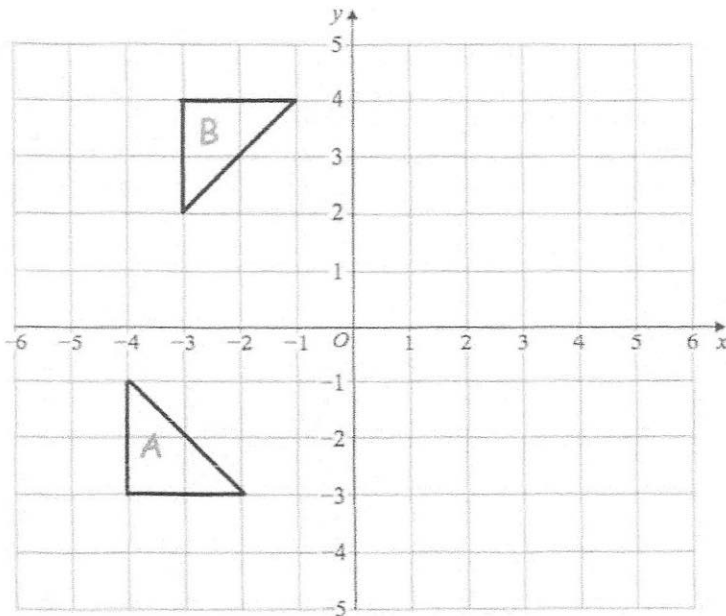

Describe fully the single transformation that maps triangle A onto triangle B.

..... Rotation 90° clockwise using $(0,0)$ as centre of rotation

(2)

61

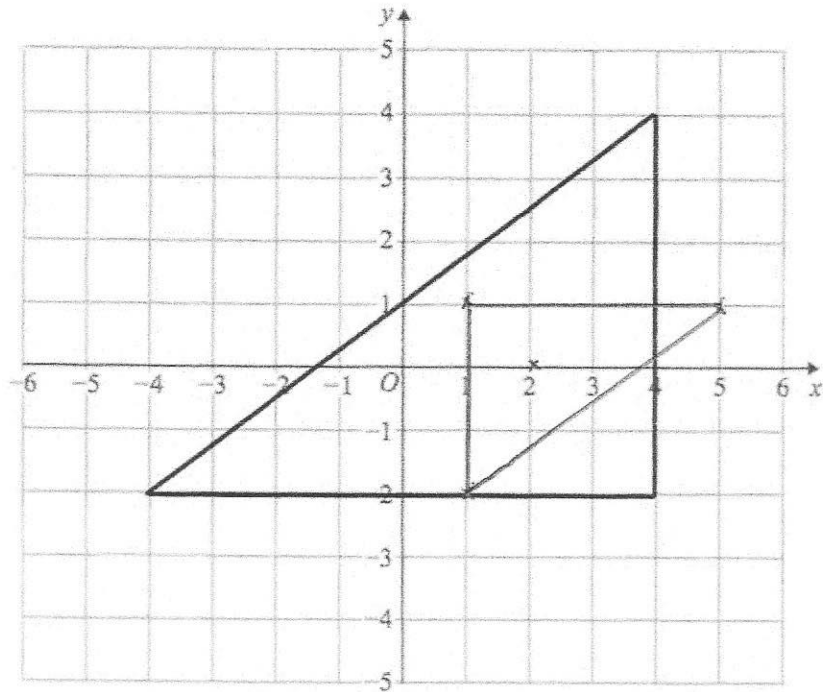

Enlarge the triangle by scale factor $-\frac{1}{2}$, using centre of enlargement $(2, 0)$

(3)

62

Mrs Hampton is potting plants.

She is using two mathematically similar pots, the smaller is 10cm tall and the larger 14cm tall.

She has two bags of soil, each containing 30 litres of soil.

With the first bag, Mrs Hampton fills 20 small pots using all of the soil in the bag.

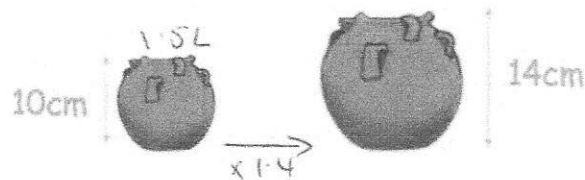

How many large pots can be filled completely using the second bag of soil?

$$30 \div 20 = 1.5 \text{ Litres}$$

$$1.5 \times 1.4^3 = 4.116 \text{ Litres}$$

$$30 \div 4.116 = 7.28$$

.....7.....

(5)

63

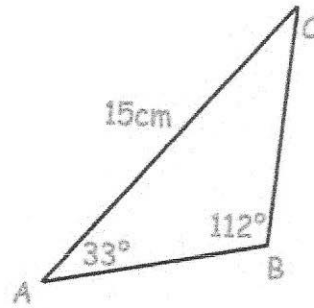

In triangle ABC the length of AC is 15cm.

Angle ABC = 112°

Angle BAC = 33°

Work out the length of BC.

$$\frac{x}{\sin 33} = \frac{15}{\sin 112}$$

8.81

.....cm

to 2dp (3)

64

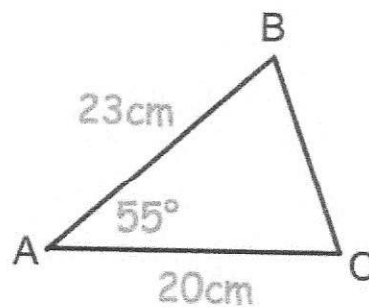

Calculate the length of BC.

$$x^2 = 23^2 + 20^2 - 2(20)(23) \cos 55$$

$$x^2 = 401.3...$$

20.03

.....cm

(3)

65

DFG is a straight line.

$$\overrightarrow{DE} = 4\mathbf{a} \quad \text{and} \quad \overrightarrow{EF} = 6\mathbf{b}$$

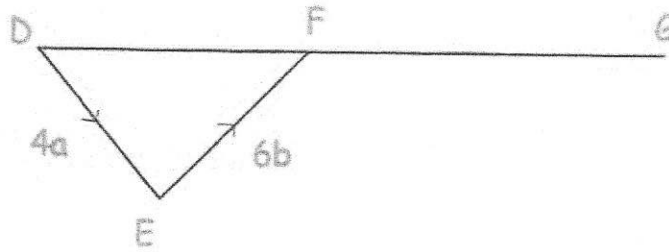

- (a) Write down the vector \overrightarrow{DF} in terms of \mathbf{a} and \mathbf{b}

$$\frac{4\mathbf{a} + 6\mathbf{b}}{\quad\quad\quad} \quad (1)$$

- (b) $DF : FG = 2 : 3$

Work out the vector \overrightarrow{DG} in terms of \mathbf{a} and \mathbf{b}
Give your answer in its simplest form.

$$(4\mathbf{a} + 6\mathbf{b}) \div 2 = 2\mathbf{a} + 3\mathbf{b}$$

$$(2\mathbf{a} + 3\mathbf{b}) \times 5$$

$$\frac{10\mathbf{a} + 15\mathbf{b}}{\quad\quad\quad} \quad (2)$$

66

$$\mathbf{a} = \begin{pmatrix} 9 \\ 6 \end{pmatrix} \quad \text{and} \quad \mathbf{b} = \begin{pmatrix} 4 \\ -1 \end{pmatrix}$$

Work out $3\mathbf{a} - \mathbf{b}$

$$3\mathbf{a} = \begin{pmatrix} 27 \\ 18 \end{pmatrix} \quad \mathbf{b} = \begin{pmatrix} 4 \\ -1 \end{pmatrix}$$

$$\begin{pmatrix} 23 \\ \dots \\ 19 \\ \dots \end{pmatrix} \quad (2)$$

67

The diagram shows a solid triangular prism.

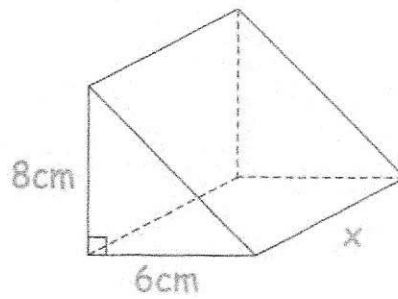

The prism is made from wood and has a mass of 643.8g
The density of wood is 1.85g/cm^3

Calculate the length of the prism.

$$V = \frac{m}{\rho} \quad \frac{643.8}{1.85} = 348$$

$$24 \times x = 348$$

14.5

.....cm
(4)

68

An object is placed on a table.
It exerts a force of 22 newtons on the table.

The pressure on the table is 500 newtons/m^2 .
Calculate the area of the crate that is in contact with the table.
Include suitable units.

$$A = \frac{F}{p} \quad \frac{22}{500} = 0.044\text{m}^2$$

or
 440cm^2

440cm²

.....
(3)

69

100 students study one language at a college.

Some students study French.

Some students study Spanish.

The rest of the students study German.

54 of the students are in Year 12.

20 of the 29 students who study Spanish are in Year 13.

31 students study German.

15 Year 13 students study French.

Work out the number of Year 12 students who study German.

	Year 12	Year 13	Total
French	25	15	40
Spanish	9	20	29
German	20	11	31
Total	54	46	100

20

(4)

70

A shop sells umbrellas.

The scatter graph shows information about the number of umbrellas sold each week and the rainfall that week, in millimetres.

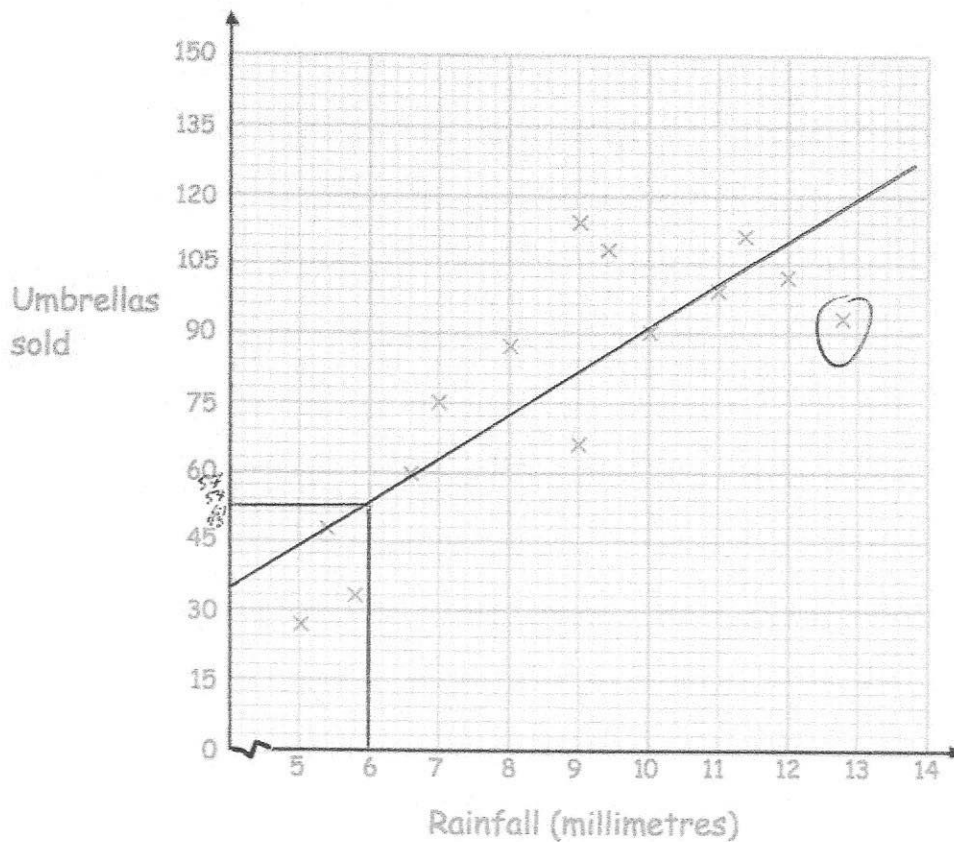

(a) Describe the relationship between the rainfall and umbrellas sold.

As the rainfall increases, so does the number of umbrellas sold.

(1)

(b) What is the greatest amount of rainfall in one week?

12.8 mm

(1)

In another week, there was 6mm of rain.

(c) Estimate the number of umbrellas sold.

53

(2)

(d) Explain why it may **not** be appropriate to use your line of best fit to estimate the number of umbrellas sold in a week with 25mm of rainfall.

It is extrapolation (beyond the range of the given data).
therefore is unreliable.

(1)

71

The histograms shows information about the time taken by 140 students to complete a puzzle.

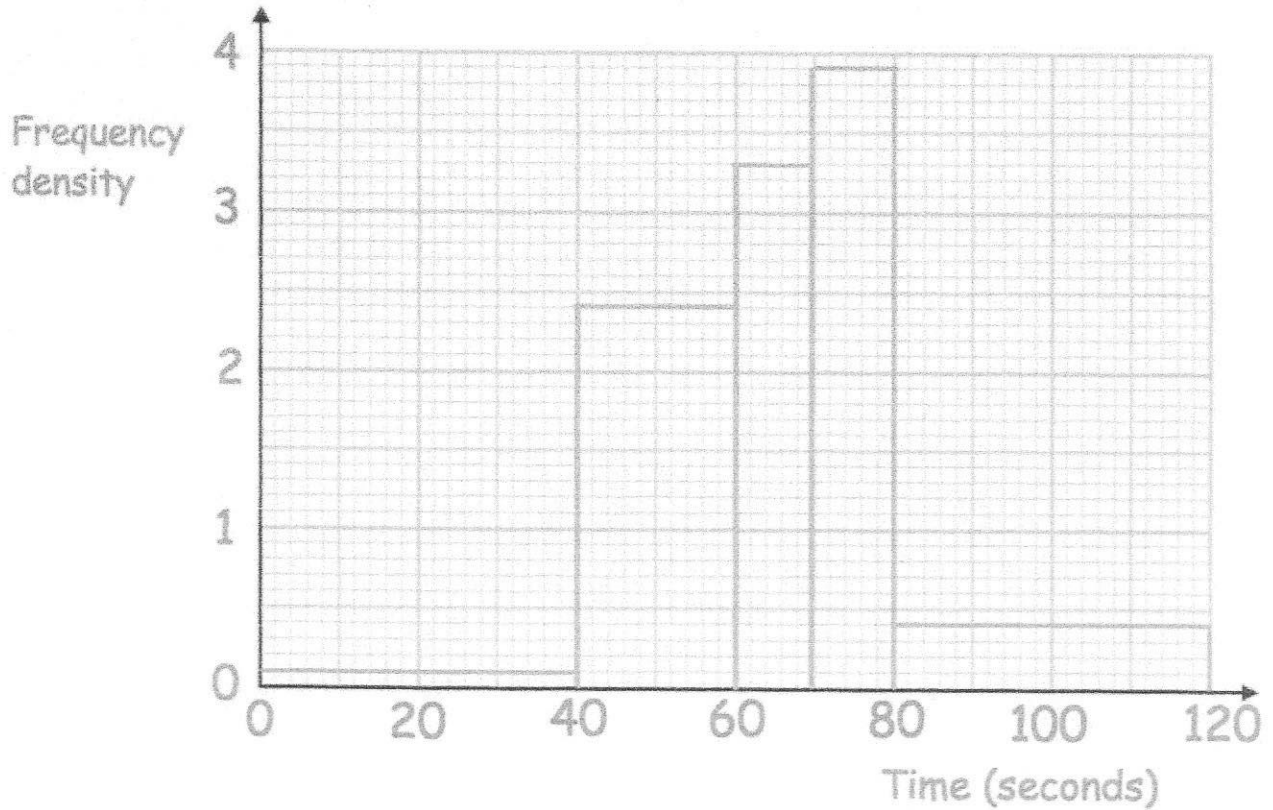

(a) Complete this frequency table.

Time, t seconds	Frequency
$0 < t \leq 40$	4
$40 < t \leq 60$	48
$60 < t \leq 70$	33
$70 < t \leq 80$	39
$80 < t \leq 120$	16

$$20 \times 2.4$$

$$3.9 \times 10$$

(2)

(b) Calculate an estimate of the median.

70th value

$$60 + \frac{18}{33} \times 10 = 65.455 \text{ seconds}$$

(3)

72

The length of time, in minutes, that 80 customers spend in a shop was recorded. A cumulative frequency diagram of this data is below.

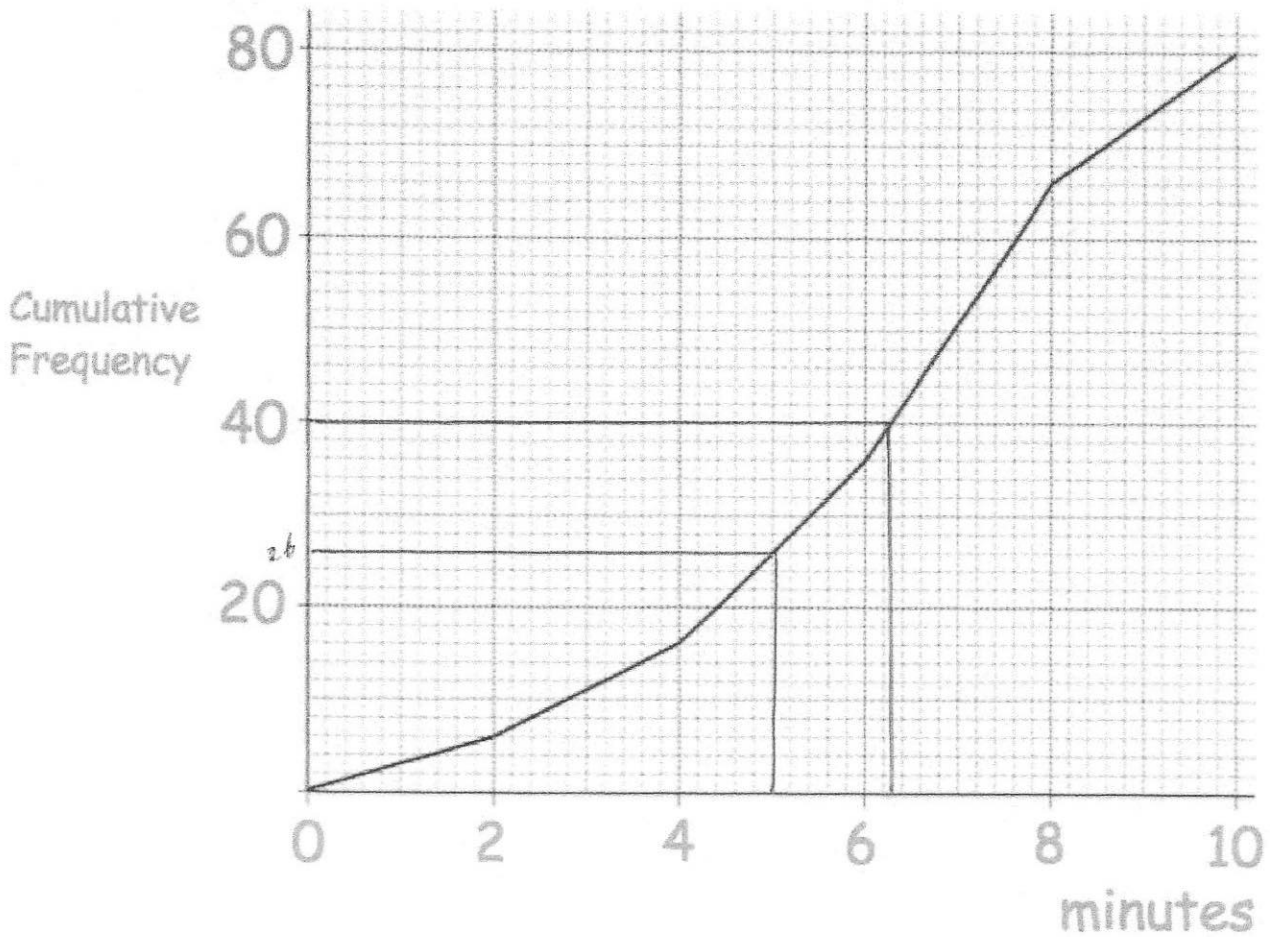

(a) Find an estimate of the median.

.....6.3.....minutes
(1)

(b) Estimate how many customers spent more than 5 minutes in the shop.

$$80 - 26 = 54$$

.....54.....
(1)

73. Timothy weighs the mass of some oranges, in grams. The table shows some information about his results.

Mass	Frequency
$20 < m \leq 25$	12
$25 < m \leq 30$	24
$30 < m \leq 35$	17
$35 < m \leq 40$	15
$40 < m \leq 45$	4

midpoint	fx
22.5	270
27.5	660
32.5	552.5
37.5	562.5
42.5	+170
	<u>2215</u>

Work out an estimate for the mean mass of an orange.

$$2215 \div 72$$

$$\begin{array}{r} 30.764 \dots \text{grams} \\ \text{to 3dp} \end{array} \quad (4)$$

74. There are 8 sweets in a bag. Three sweets are red, three sweets are blue and two sweets are green.

Three sweets are selected at random **without** replacement.

Calculate the probability that the sweets are **not** all the same colour.

$$P(RRR) = \frac{3}{8} \times \frac{2}{7} \times \frac{1}{6} = \frac{1}{56}$$

$$P(BBB) = \frac{1}{56}$$

$$P(\text{Not same}) = 1 - \frac{2}{56} = \frac{54}{56}$$

$$\frac{27}{28}$$

(4)

75. The Venn diagram shows information about the cars in a car park.

$\xi = 150$ cars in the car park

R = red cars

J = cars manufactured in Japan

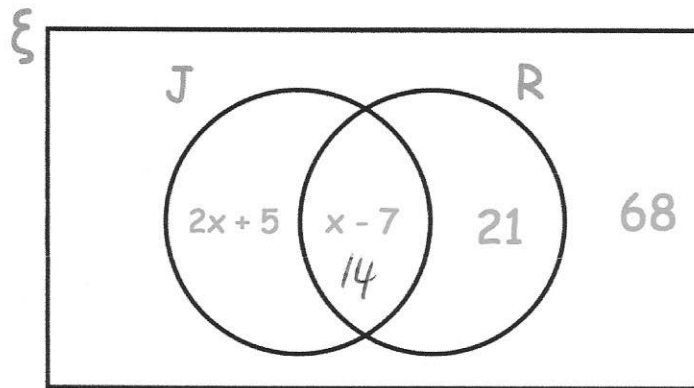

A car is chosen at random.

Work out the probability that it is red.

$$(2x + 5) + (x - 7) + 21 + 68 = 150$$

$$3x + 87 = 150$$

$$3x = 63$$

$$x = 21$$

$$14 + 21 = 35$$

$$\begin{array}{r} 35 \\ \hline 150 \end{array}$$

$$\frac{7}{30}$$

.....
(4)

76. Write down the reciprocal of 0.35



$$\frac{7}{20} \rightarrow \frac{20}{7}$$

$$\frac{20}{7}$$

.....
(1)

77.

(a) Use the fact 5 miles = 8 kilometres to draw a conversion graph on the grid.

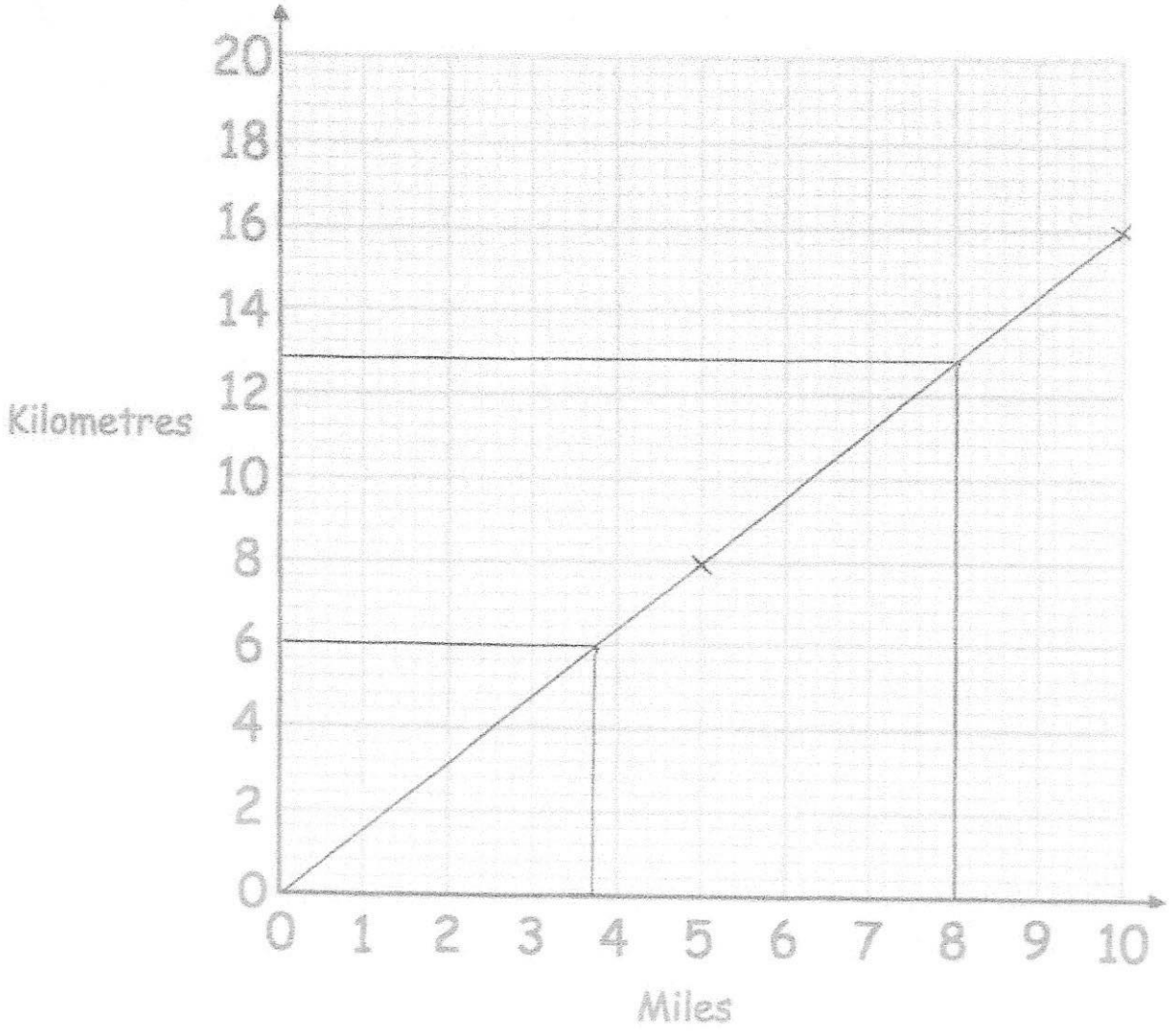

(2)

Use your graph to convert

(b) 8 miles to kilometres

..... 12.8 km
or 12.7 etc
(1)

(c) 6 kilometres to miles

..... 3.75 miles
(1)

78. Simplify

$$\frac{a^{1/5} \times a^{2/3}}{a^{3/5}}$$

$$\frac{1}{5} + \frac{2}{3} = \frac{3}{15} + \frac{10}{15} = \frac{13}{15}$$

$$\frac{13}{15} - \frac{3}{5}$$

$$\frac{13}{15} - \frac{9}{15} = \frac{4}{15}$$

$$a^{4/15}$$

(2)

79. Terry goes to the Post Office to exchange money.

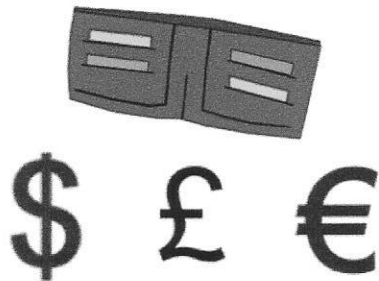

Exchange Rates

£1 : \$1.55

£1 : €1.24

*Commission Charged

Terry changes \$651 and €161.20 into pounds sterling.

The Post Office deducts their commission and gives Terry £528.

What is the percentage commission?

$$\text{\$651} \rightarrow \text{\pounds420}$$

$$\text{\pounds161.20} \rightarrow \text{\pounds130}$$

$$\underline{\text{\pounds550}}$$

4

.....%
(4)

$$\frac{22}{550} \times 100 = 4$$

80. y is directly proportional to the square of x .
When $y = 24$, $x = 2$.

Find the value of y when $x = 4$.

$$y \propto x^2$$

$$y = kx^2$$

$$24 = k \times 4$$

$$k = 6$$

$$y = 6x^2$$

$$y = 6 \times 4^2$$

$$y = 6 \times 16$$

$$y = \dots\dots\dots 96$$

(3)

81. Match each graph to the correct relationship.

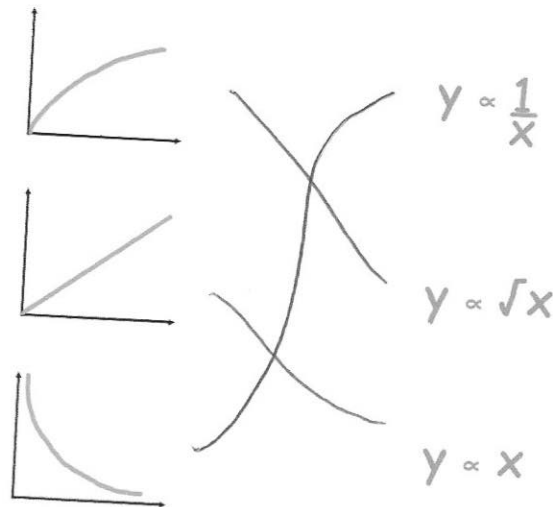

(3)

82. It takes 6 hours for 20 workers to seed 40 acres.

How long would it take 10 workers to seed 90 acres?

$$6 \times 20 = 120$$

$$120 \div 40 = 3 \text{ hrs for 1 worker for 1 acre}$$

$$90 \times 3 = 270 \text{ hrs for 1 worker}$$

$$270 \div 10 = 27 \text{ hrs for 10 workers}$$

$$\dots\dots\dots 27 \text{ hours}$$

(3)

83. Simplify $9h + 5k + 4h - 8k$

$$\frac{13h - 3k}{(2)}$$

84. Factorise fully

$$w^2y + wy^2$$

$$\frac{wy(w+y)}{(2)}$$

85. (a) Factorise $y^2 - 13y + 36$

$$\frac{(y-4)(y-9)}{(2)}$$

(b) Factorise $2w^2 - 9w + 4$

$$\frac{(2w-1)(w-4)}{(2)}$$

86. M is the midpoint of PQ

Write down the coordinates of the point Q.

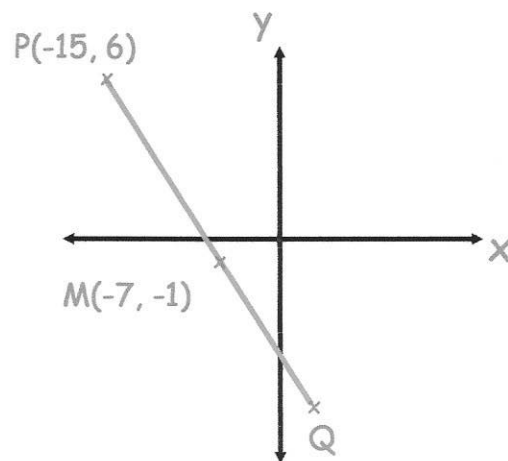

(1, -8)
(2)

87. Shown below are the points A(1, 4) and B(7, 15)

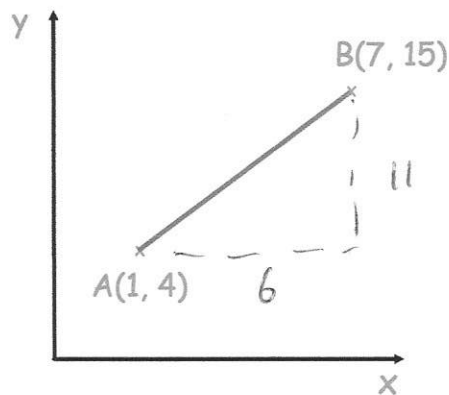

Calculate the length of the line joining A and B.

$$6^2 + 11^2 = 157$$

$$\sqrt{157} = 12.5299\dots$$

12.53
to 2dp (2)

88

The straight line $y = -2x + 4$ has been drawn on the grid.

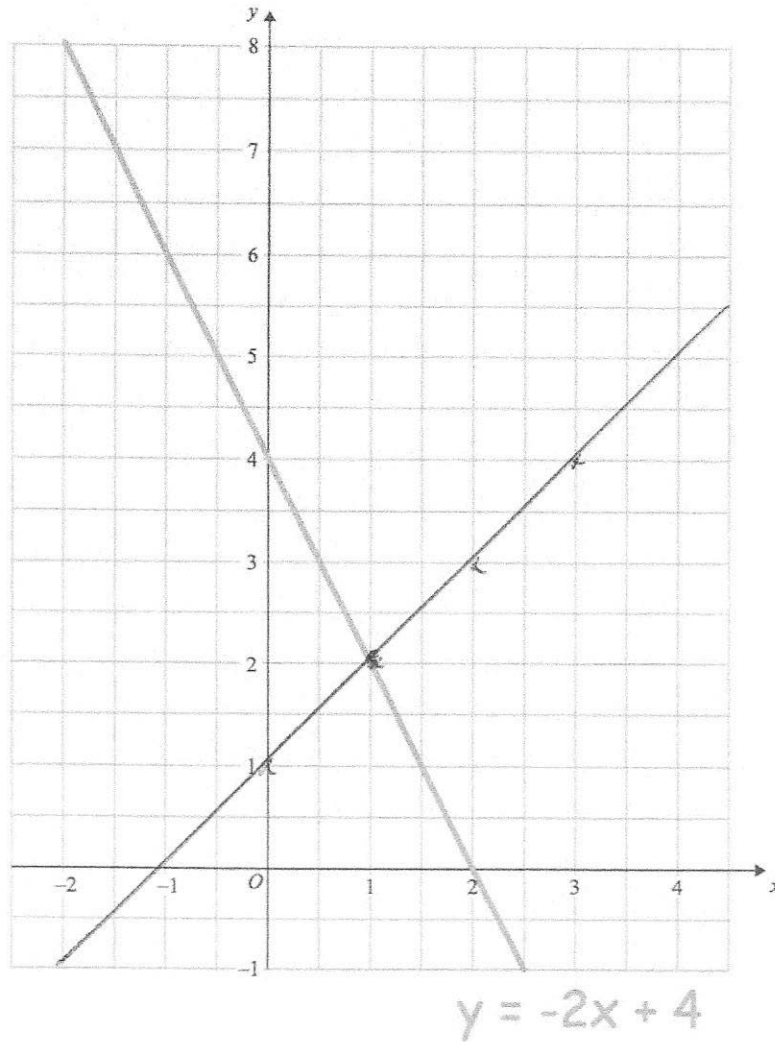

(a) On the same grid, draw the graph of $y = x + 1$

(2)

(b) Use the graphs to solve the simultaneous equations

$$y = -2x + 4$$

$$y = x + 1$$

$$x = 1, y = 2$$

(2)

89

(a) Complete the table of values for $y = x^2 + 2x + 1$

x	-3	-2	-1	0	1	2	3
y	4	1	0	1	4	9	16

(2)

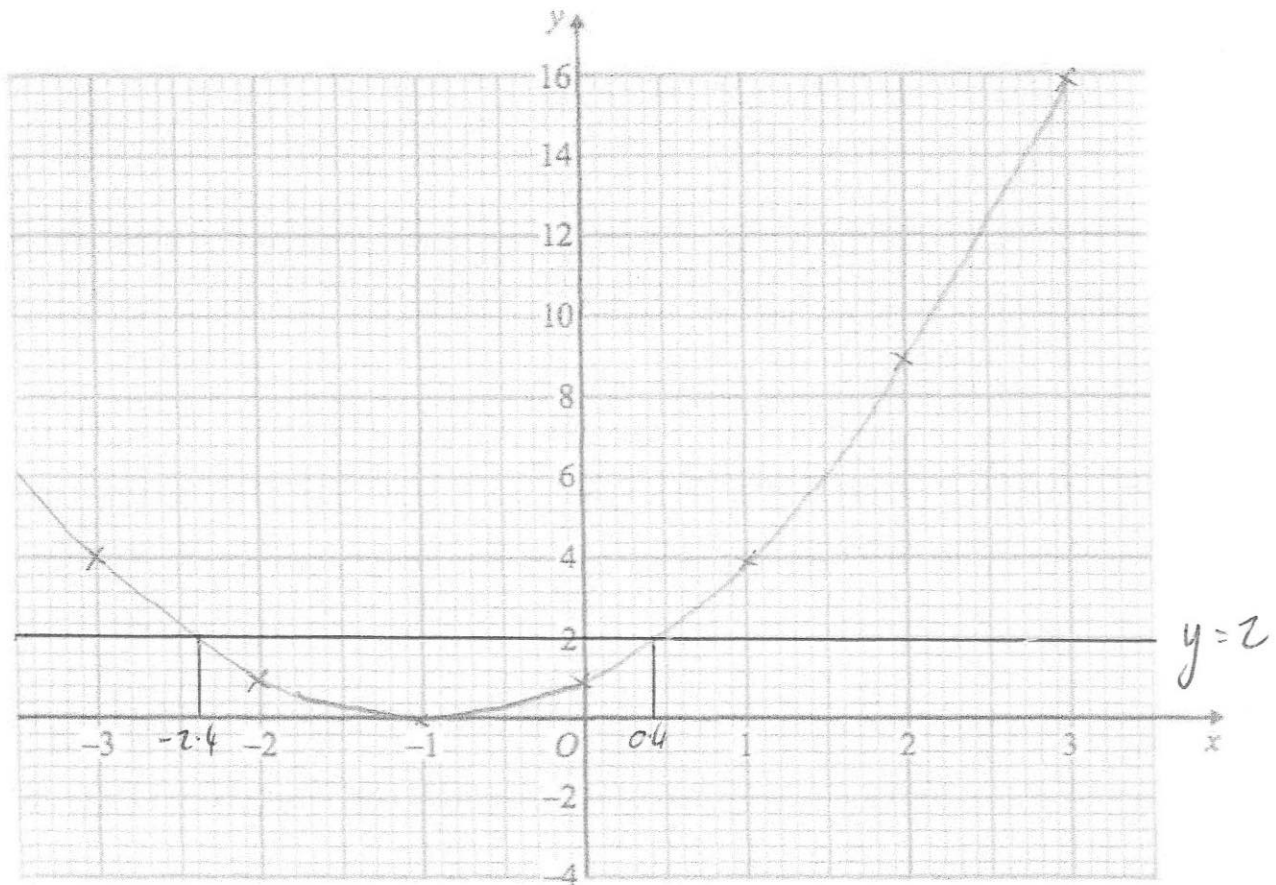
(b) On the grid, draw the graph of $y = x^2 + 2x + 1$ for the values of x from -3 to 3.

(2)

90

$$x = 0.4 \quad \text{or} \quad x = -2.4$$

91. Sketch the graph of $y = x^2 + 7x - 8$

$$0 = (x+8)(x-1)$$

$$x = -8 \quad x = 1$$

$$y = 0^2 + 0 - 8$$

$$y = -8$$

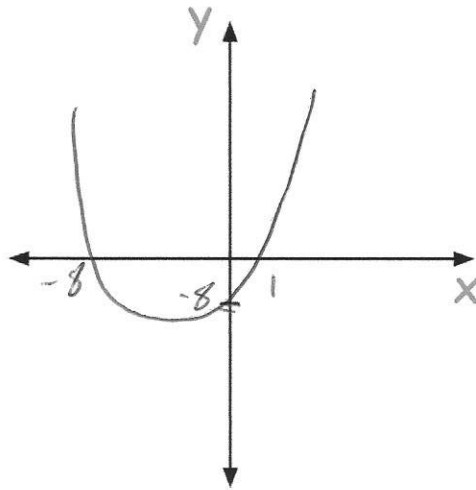

(3)

92. $9x^3 + (x+a)(x+b) + cx \equiv ax^3 + x^3 + x^2 + 12x - 24$

Work out the values of a , b and c .

$$ax^3 + x^2 + ax + bx + ab + cx \equiv ax^3 + x^3 + x^2 + 12x - 24$$

x^3

$$a = a + 1$$

$$a = 8$$

x

$$b + a + c = 12$$

$$b + 8 + c = 12$$

$$b + c = 4$$

$$c = 7$$

Constants

$$ab = -24$$

$$8b = -24$$

$$b = -3$$

$$a = \dots 8 \dots$$

$$b = \dots -3 \dots$$

$$c = \dots 7 \dots$$

(3)

93. In the diagram, AB is parallel to CD.

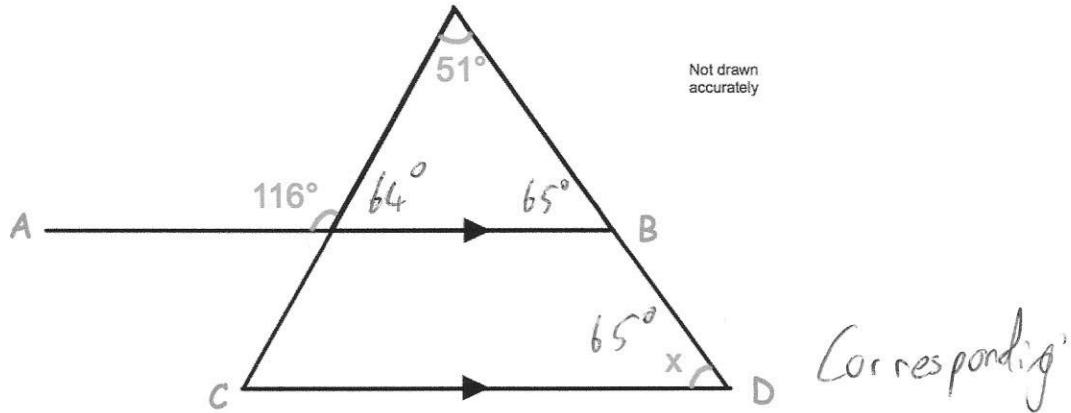

Work out the size of angle x.

You **must** show your workings.

$$180 - 116 = 64$$

$$51 + 64 = 115$$

$$180 - 115 = 65$$

$$\dots\dots\dots 65^\circ$$

(4)

94. James has a bicycle.
Each wheel has diameter 45cm.

James cycles his bicycle in a straight line in the playground.
The front wheel makes 15 complete revolutions.

How far does the bicycle travel?
Give your answer in metres.

$$\pi \times 45 = 141.37166\dots \text{ cm}$$

$$141.37166\dots \times 15 = 2120.57\dots \text{ cm}$$

$$\div 100$$

$$\dots\dots\dots 21.206 \text{ m}$$

(4)

95

A logo is designed that has four pink circles within a white square.

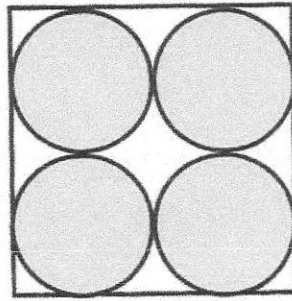

16cm

The square has side length 16cm.

Find the area of the logo that is white.

$$\begin{aligned} \pi \times 4^2 &= 50.265\dots \\ 50.265\dots \times 4 &= 201.0619\dots \\ 16 \times 16 &= 256 \\ 256 - 201.0619\dots & \end{aligned}$$

$$\underline{\underline{54.94\dots}} \text{cm}^2$$

(5)

96

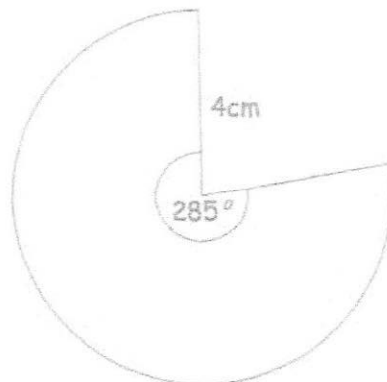

Calculate the perimeter of the sector.

$$\begin{aligned} \frac{285}{360} \times \pi \times 8 &= 19.896\dots \\ 19.896\dots + 4 + 4 &= 27.896\dots \end{aligned}$$

$$\underline{\underline{27.897\dots}} \text{cm}$$

(3)

97

Shown below is a square based pyramid.
The apex E is directly over the centre of the base.

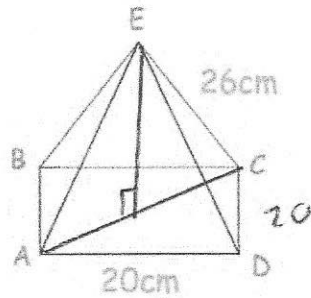

$$AD = 20\text{cm}$$

$$CE = 26\text{cm}$$

(a) Work out the length of AC

$$20^2 + 20^2 = 400 + 400 \\ = 800$$

$$AC = \sqrt{800} \quad AC = 20\sqrt{2}$$

$$\begin{array}{r} 28.3 \\ \hline \text{to 1 dp (2)} \end{array}$$

(b) Calculate angle CAE

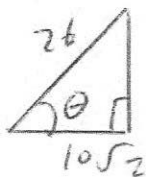

$$\cos \theta = \frac{10\sqrt{2}}{26}$$

$$\begin{array}{r} 57.05 \\ \hline \text{to 2 dp (2)} \end{array}$$

(c) Work out the height of the pyramid

$$26^2 - (10\sqrt{2})^2 \\ = 476 \\ \sqrt{476}$$

$$\begin{array}{r} 21.82 \\ \hline \text{to 2 dp (2)} \end{array}$$

98

Convert 552 cm^2 into m^2

$$552 \div 100^2$$

$$\begin{array}{r} 0.0552 \\ \hline \text{m}^2 \\ \text{(1)} \end{array}$$

99. A remote control car drives in a straight line.
It starts from rest and travels with constant acceleration for 20 seconds reaching a velocity of 12m/s.
It then travels at a constant speed for 20 seconds.
It then slows down with constant deceleration of 4m/s^2 .

(a) Draw a velocity time graph

Velocity, m/s

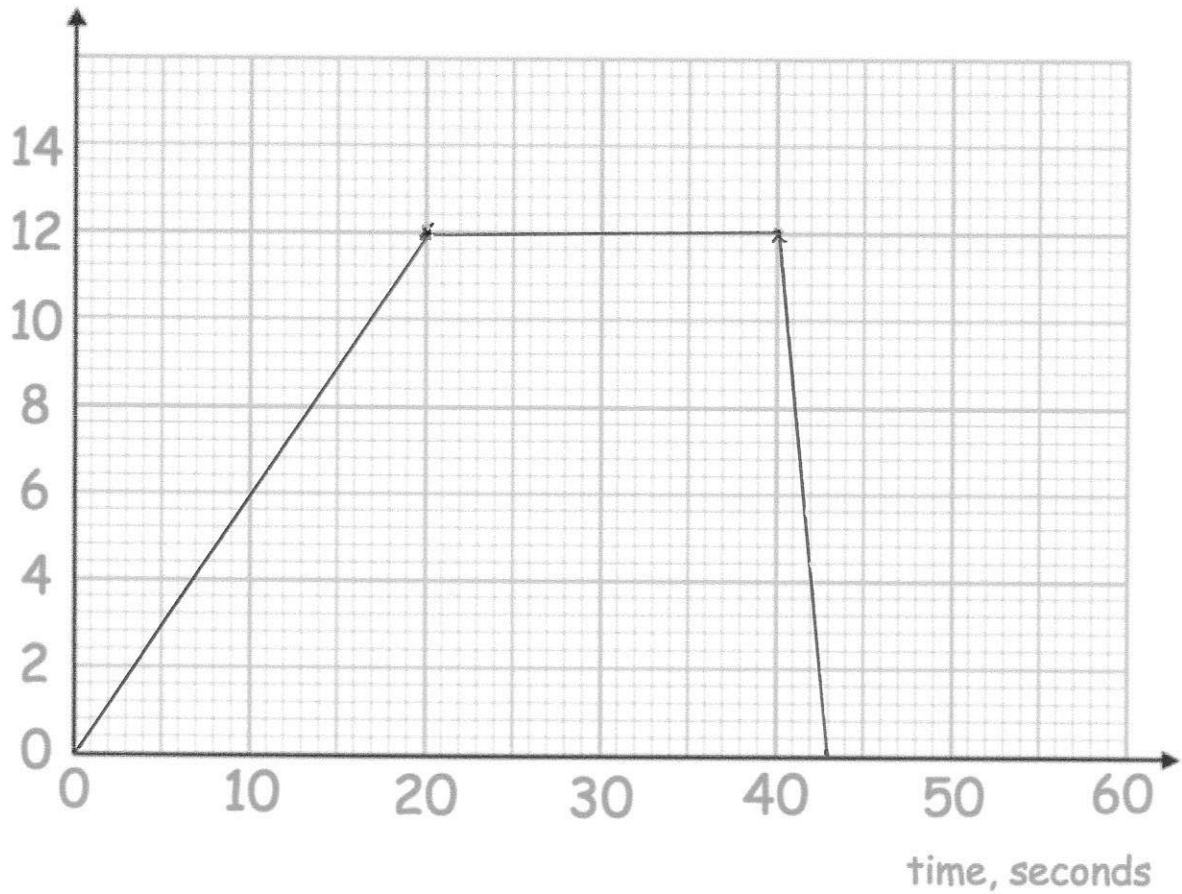

100. For each pair below, state the condition why they are congruent.

(a)

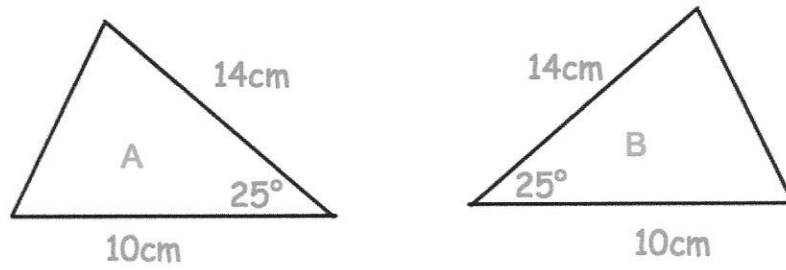

Condition: *SAS*
(1)

(b)

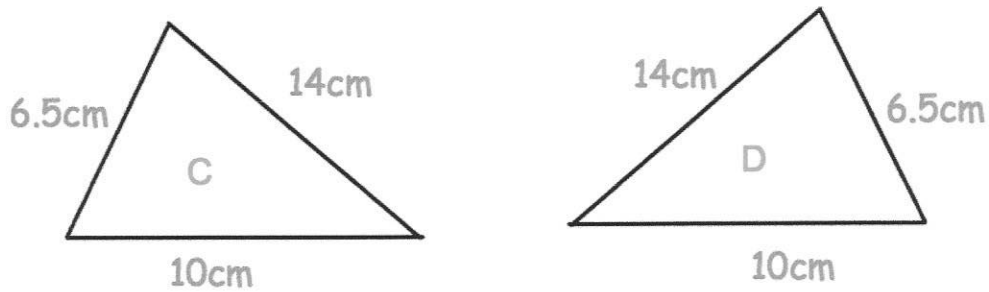

Condition: *SSS*
(1)

(c)

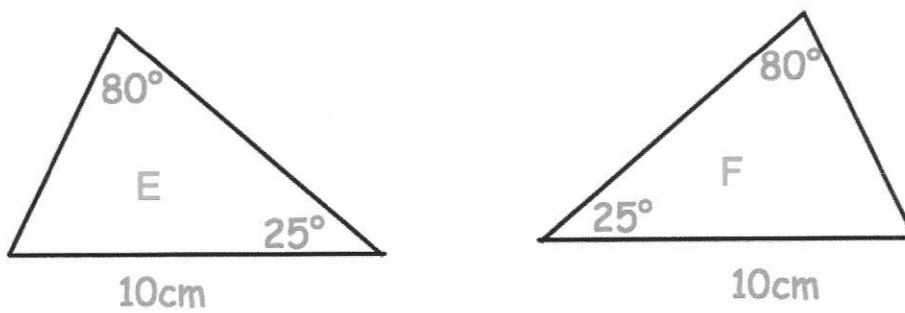

Condition: *ASA*
(1)

1018

Here is shape ABCDEF

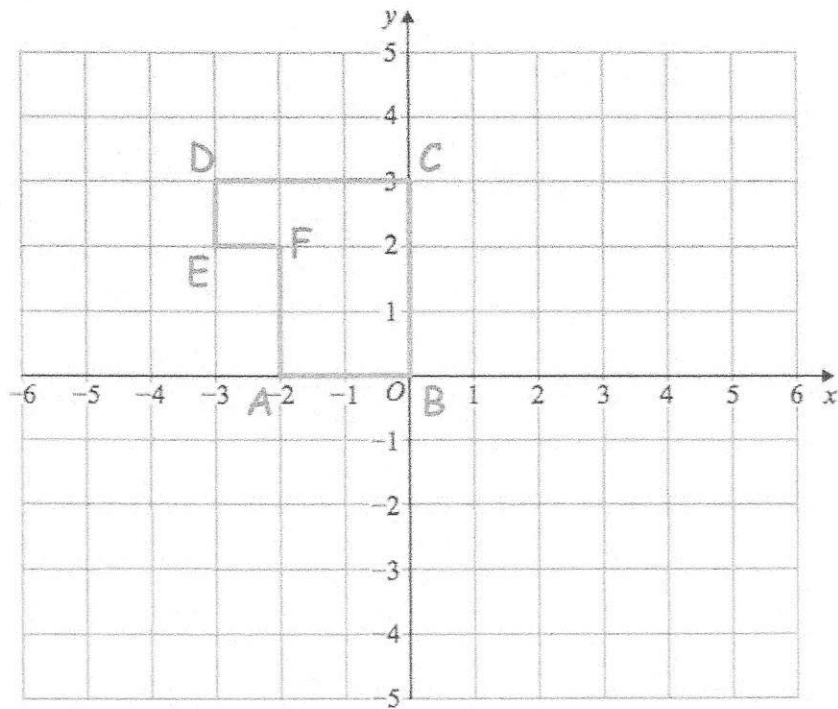

Describe fully a **single** transformation so that only vertex F is invariant.

Rotation of 180° about centre $(-2, 2)$

.....

.....

.....

102. 140 students sign up for a college course.
 At the end of the course, each student has two attempts to pass a test.
 If a student passes either attempt, they are awarded a certificate

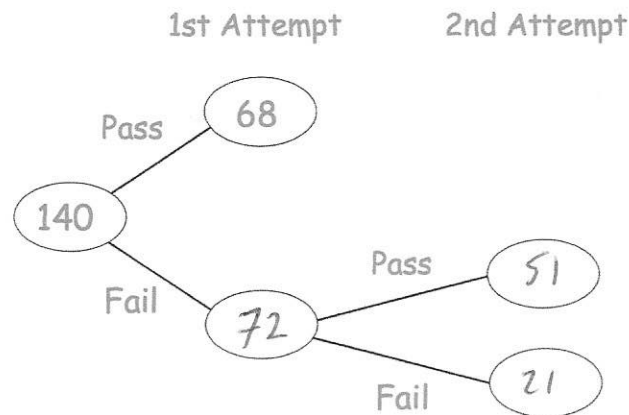

85% of the students receive a certificate.

Work out how many students passed the test in their 2nd attempt.

$$85\% \text{ of } 140 = 119$$

$$119 - 68 = 51$$

(3)

103. A biased coin is flipped twice.

The probability of the coin landing on tails is 0.7

$$P(\text{head}) = 0.3$$

Find the probability the coin lands on heads twice.

$$0.3 \times 0.3$$

$$\underline{\underline{0.09}}$$

(2)

104

5 Year 10 students and 45 Year 11 students sit a test.

The mean mark for the whole group is 70

The mean mark for the Year 11 students is 72

Work out the mean mark for the Year 10 students.

$$50 \times 70 = 3500$$

$$45 \times 72 = 3240$$

$$\underline{260}$$

$$260 \div 5 = 52$$

$$\underline{52}$$

(2)

105

A manager recorded how long each customer spent in his supermarket.
The table shows his results.

$$\frac{200}{2} = 100^{\text{th}}$$

or

$$\frac{201}{2} = 100.5^{\text{th}}$$

Time, t (minutes)	Frequency
$0 < t \leq 10$	24
$10 < t \leq 20$	31
$20 < t \leq 30$	50
$30 < t \leq 40$	35
$40 < t \leq 50$	60

200

Which class interval contains the median?

$$\underline{20 < t \leq 30}$$

(1)

106

The table shows the number of pages in 100 books.

Number of pages, x	Frequency
$0 < x \leq 100$	7
$100 < x \leq 200$	25
$200 < x \leq 300$	40
$300 < x \leq 400$	12
$400 < x \leq 500$	16

Write down the modal class interval.

$$\underline{200 < x \leq 300}$$

(1)

A three-sided spinner is labelled A, B and C.

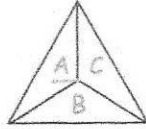

The spinner is spun and the frequency the letter A is recorded every 10 spins. The table below shows this information.

Spins	10	20	30	40
Frequency of an A	5	12	21	26

$$\frac{5}{10} = 0.5 \quad \frac{12}{20} = 0.6 \quad \frac{21}{30} = 0.7 \quad \frac{26}{40} = 0.65$$

(a) Complete plot the relative frequencies on the graph below.

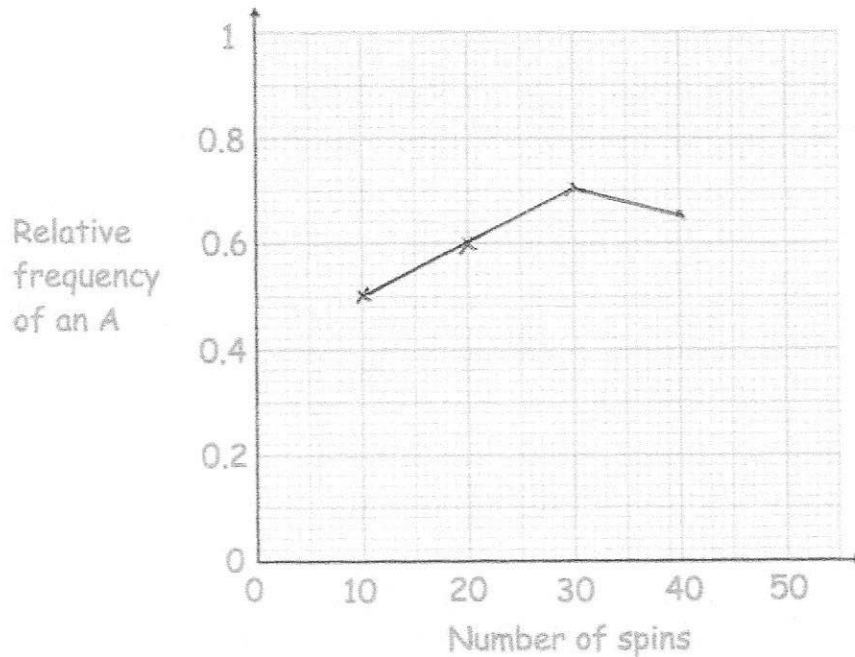

(3)

(b) Neil says the relative frequency after 50 spins is 0.8
Explain why Neil must be wrong

$50 \times 0.8 = 40$, that would mean 14 more A
in 10 spins - not possible.

(2)

108. 480 students attend a school.

A teacher asks 50 students which colour they would like the new school blazer to be.

The table shows the results.

Colour	Number of students
Black	20
Navy	15
Green	9
Maroon	6

Estimate how many of the 480 students would like a black blazer.

$$\frac{20}{50} \times 480$$

$$\frac{192}{\dots\dots\dots}$$

(2)