

Paper 2 and Paper 3 Preparation Paper

OCR Foundation



Corbettmαths

Ensure you have: Pencil, pen, ruler, protractor, pair of compasses and eraser

You will need a calculator

Guidance

1. Read each question carefully before you begin answering it.
2. Check your answers seem right.
3. Always show your workings

Paper 2 and 3 Checklist



Question	Topic	Video number
Starred Topics		
1	Angle Facts	35,30,34,39
2	Types of Angle	38
3	Angle in Parallel Lines	25
4	Angles in a Triangle	37
5	Angles in a Quadrilateral	33
6	Angles in Polygons	32
7	Area of Rectangles/Triangles	45, 49
8	Area of a Trapezium	48
9	Line Symmetry	316
10	Rotational Symmetry	317
11	Constructions	72,78,83
12	Loci	75,76,77
13	Faces, Edges, Vertices	5,3
14	Nets	4
15	Views and Elevations	354
16	Time Calculations	322
17	Timetables	320
18	Speed	299
19	Density	384
20	Translations	325, 326
21	Rotations	275
22	Enlargements	104,105,107
23	Volume of a Cylinder	357
24	Exact Trig Values	341
25	Volume of a Cuboid/Prism	355,356
26	Volume of a Cone/Sphere	359,361
27	Surface Area	310

Question	Topic	Video number
28	Surface area of Sphere/Cone	313,314
29	Multiplication	199,200
30	Division	98
31	Addition	6
32	Subtraction	304
33	Rounding	276,277a,277b,278,280
34	Estimation	215
35	Order of Operations	211
36	Arithmetic with Decimals	90,91,92,93,94
37	Square Numbers and Square Roots	226,228
38	Fractions of Amounts	137
39	Adding Fractions	133
40	Multiplying Fractions	142
41	Dividing Fractions	134
42	Reciprocals	145
43	Expressing as Fraction or %	136,237
44	Percentages of Amounts	234,235,238
45	Percentage Change	233
46	Reverse Percentages	240
47	Ratio	269,270,271
48	Currency	214a
49	Recipes	256
50	Error Intervals	377
51	Money	400
52	Best Buys	210
53	Two-way Tables	319
54	Pictograms	161,162
55	Bar Charts	147,148
56	Probability	245,246,248
57	Listing Outcomes	253

Question	Topic	Video number
58	Combined Mean	53a
59	Estimated Mean	55
60	Venn Diagrams	380
61	Tree Diagrams	252
62	Writing Expressions	16
63	Collecting Like Terms	9
64	Sequences	286,287,290,287a
65	Geometric Progressions	375
66	The nth Term	288
67	Expanding Brackets	14
68	Factorising	117
69	Factorising Quadratics	118,120
70	Solving Equations	110,113,266
71	Forming Equations	114,115
72	Drawing Linear Graphs	186
73	Real Life Graphs	171a
74	Changing the Subject	7
75	Simultaneous Equations	295,297
76	Quadratic graphs	264
Other Unseen Topics (or usually more prominent)		
77	Perimeter	241
78	Units	347,349
79	Sensible Estimates	285
80	Distance Charts	318
81	Travel Graphs	171
82	Pressure	385
83	Reflections	272, 273
84	Parts of the Circle	61
85	Area of a Circle	59
86	Area of a Sector	46

Question	Topic	Video number
87	Pythagoras	257
88	Trigonometry	329,330,332
89	Similar Shapes (sides)	292
90	Congruent Triangles	67
91	Ordering Decimals	95
92	Multiples	220
93	Prime Numbers	225
94	Cube Roots	214
95	LCM/HCF	218,219,224
96	Indices	172
97	Negative Indices	175
98	Fractions, Decimals, Percentages	121 to 129
99	Compound Interest	236
100	Negative Numbers	205 to 209
101	Place Value	222,22a
102	Tally Charts	321
103	Line Graphs	160
104	Relative Frequency	248
105	Mode: Frequency Table	56a
106	Median: Frequency Table	51
107	Reading Tables	387
108	Function Machines	386
109	Laws of Indices	174
110	Inequalities	177,178,179
111	Conversion Graphs	151
112	$y = mx + c$	191
113	Gradient	189
114	Cubic Graphs	344
Seen Topics (remember they may still appear, so they may be worthwhile recapping)		
See website	Bearings	26, 27

Question	Topic	Video number
See website	Circumference	60, 243
See website	Arc Length	58
See website	Vectors	353a, 353
See website	Factors	216
See website	Cube Numbers	212
See website	Simple Interest	236a
See website	Proportion	255a, 254
See website	Use of a Calculator	352
See website	Frequency Trees	376
See website	Pie Charts	163, 164
See website	Scatter Graphs	165 to 168
See website	Averages and Range	56, 50, 53, 57
See website	Samples	281a
See website	Coordinates	84
See website	Multiplying and Dividing Terms	18, 11
See website	Parallel Graphs	196
See website	Scales and Maps	283
See website	Substitution	20

1.

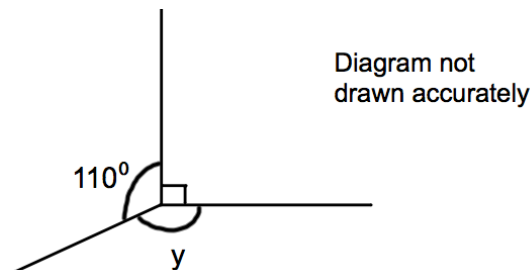

Work out the size of the angle marked y .

.....°
(1)

2.

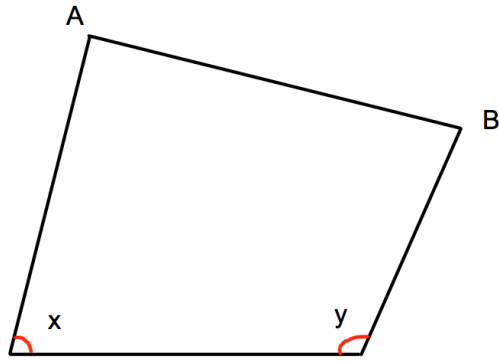

What type of angle is x ?

.....
(1)

3.

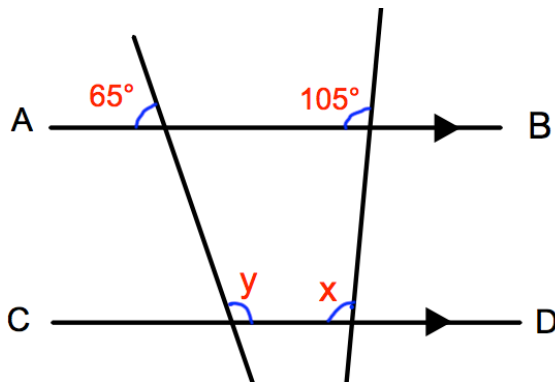

AB is parallel to CD.

(a) Work out the size of the angle marked x .

.....°

Give a reason for your answer.

.....

.....
(2)

(b) Work out the size of the angle marked y .

.....°

(2)

4.

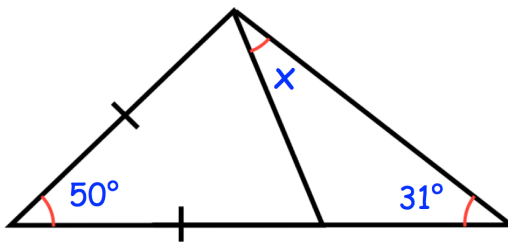

Find the size of the angle marked x.

.....°
(3)

5.

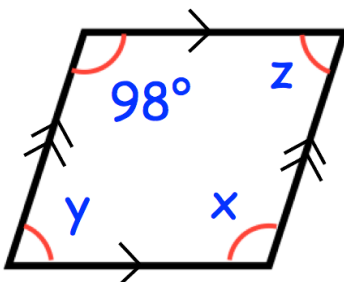

(a) Find x

.....°
(1)

(b) Find y

.....°
(1)

(c) Find z

.....°
(1)

6. Shown is a regular hexagon and a regular octagon.

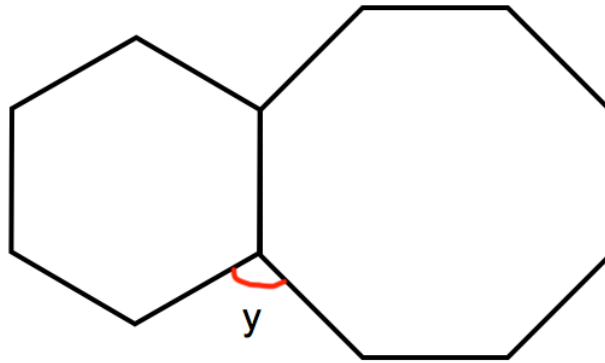

Calculate the size of angle y .

$y = \dots\dots\dots^\circ$
(3)

7. Shown below is a right-angled triangle.

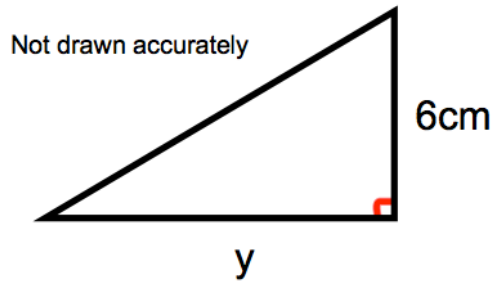

The area of the triangle is 21cm^2
Calculate y , the length of the base.

$\dots\dots\dots\text{cm}$
(2)

8.

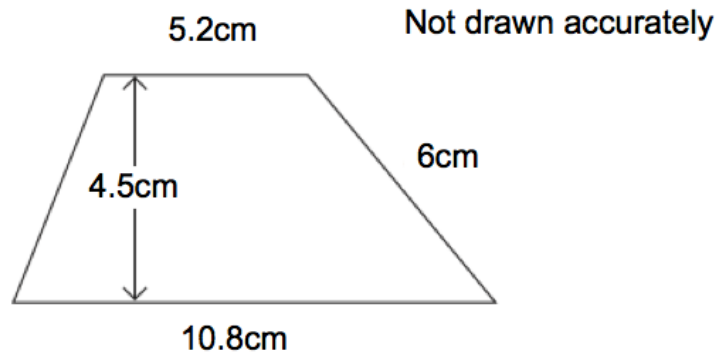

Calculate the area of the trapezium.

.....cm²
(2)

9.

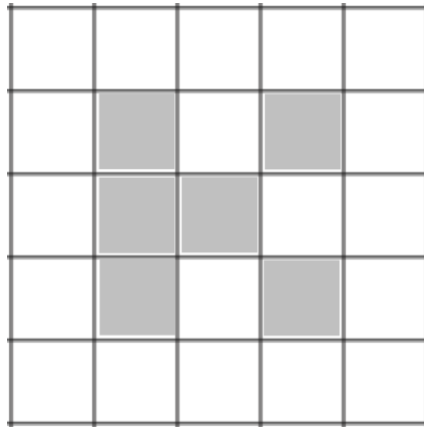

Shade one more square to make a pattern with 1 line of symmetry.

(1)

10.

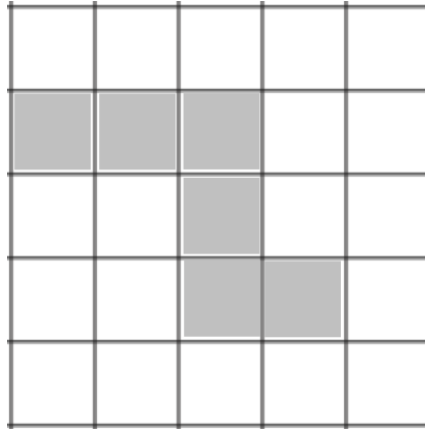

Shade one more square to make a pattern with rotational symmetry order 2.

(1)

-
11. Use ruler and compasses to construct the perpendicular bisector of AB.
You **must** show clearly all your construction arcs.

A .

. B

(2)

12. The diagram shows two lighthouses.
A boat is within than 8 miles of lighthouse A.
The same boat is within 6 miles of lighthouse B.
Shade the possible area in which the boat could be.



13. Below is a solid.

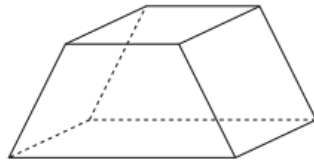

(a) Write down the number of faces

.....
(1)

(b) Write down the number of vertices

.....
(1)

14. Below are the nets of two solid shapes.

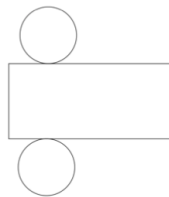

A

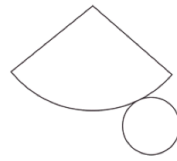

B

(a) Write down the shape that is made from Net A.

.....
(1)

(b) Write down the shape that is made from Net B.

.....
(1)

15. Shown below is a solid shape made from centimetre cubes.

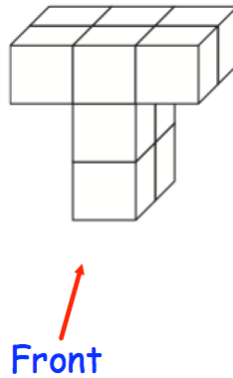

(a) On the centimetre square grid, draw the front elevation.

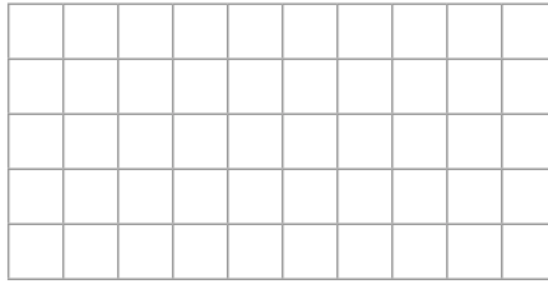

(2)

(b) On the centimetre square grid, draw the plan view.

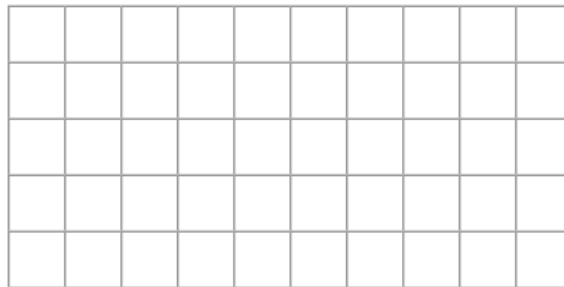

(2)

16. Connor's watch is 17 minutes slow
Joseph's watch is 5 minutes fast
The time on Joseph's watch is 19:01

What time is shown on Connor's watch?

.....
(1)

17. Here is part of a timetable for a bus.

Southville	09 18	10 38	12 05
Leek	09 28	10 48	-----
Milton	09 41	11 01	-----
Newtown	09 49	11 09	-----
Red Island	09 55	11 15	12 36
Sandville	10 13	11 33	-----
Bakerstown	10 31	11 51	13 00

A bus leaves Southville at 10 38

(a) At what time should the bus arrive at Newtown?

.....
(1)

(b) How long will the journey take?

.....minutes
(1)

James arrives at the Milton bus stop at 09 29.
He waits for the next bus to Red Island.

(c) (i) How many minutes should he wait?

.....minutes
(1)

(ii) At what time should James arrive at Red Island?

.....
(1)

Sally wants to travel from Southville to Bakerstown.
The 12 05 is an 'express' bus.

(d) How many minutes shorter is the journey if she takes the 'express bus'?

.....minutes
(2)

18. The distance from Leek to Milton is 310 miles.
A train travels this distance in 4 hours 15 minutes.

Calculate the average speed of the train.

.....mph
(3)

19. Iron has a density of 7.8g/cm^3 .
A solid iron statue has a mass of 877.5g .
Work out the volume of the statue.

..... cm^3
(2)

20.

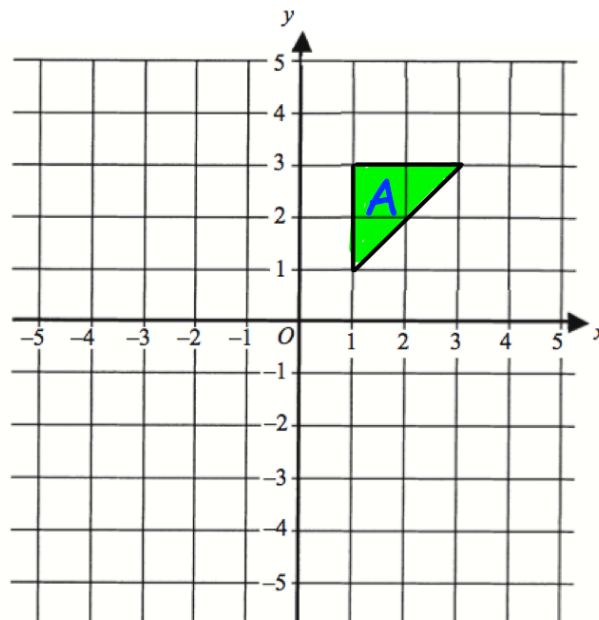

Translate triangle A by the vector $\begin{pmatrix} -3 \\ 1 \end{pmatrix}$

(2)

21.

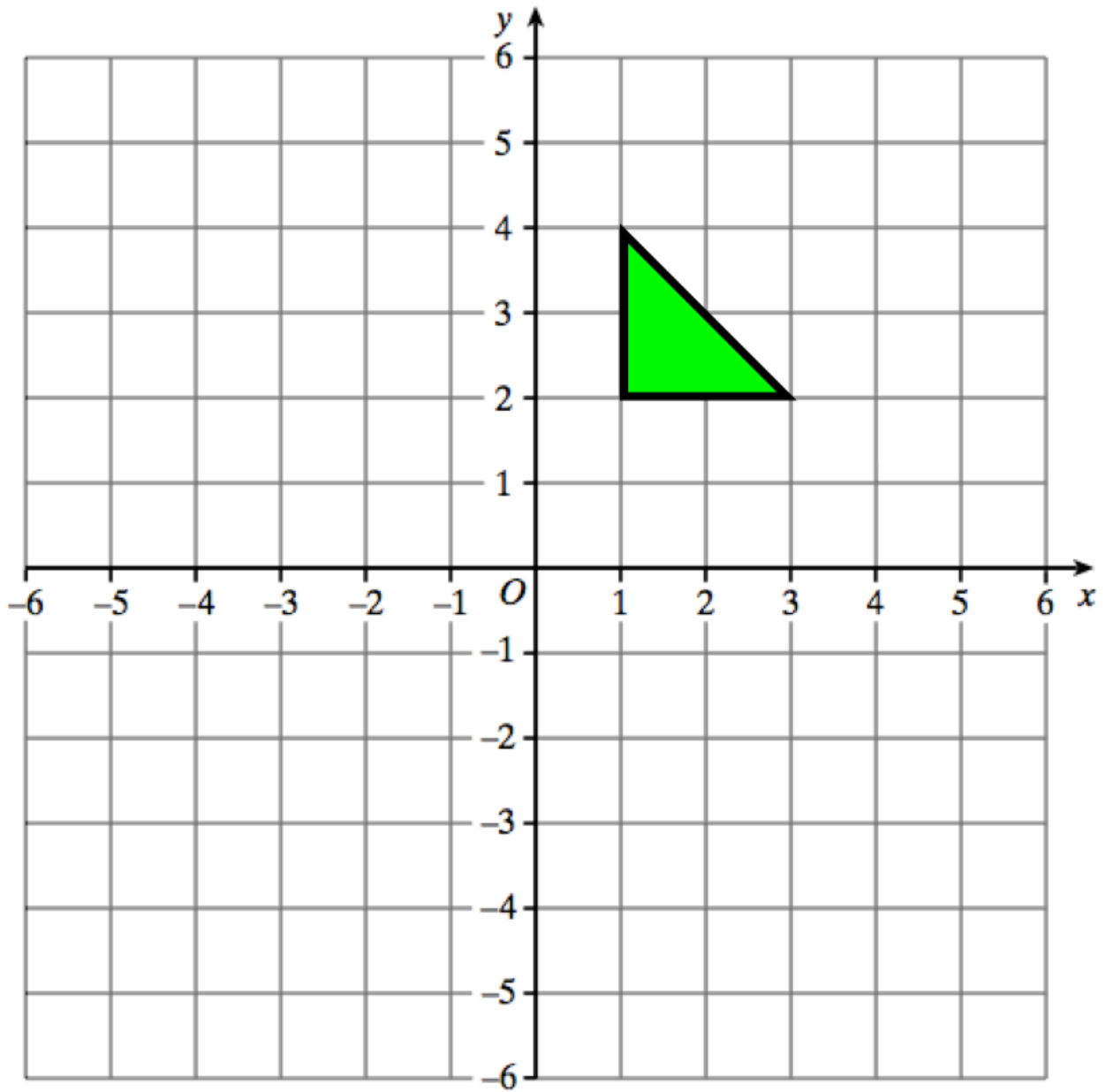

Reflect the triangle in the line $y = -1$
Label the new triangle B.

(2)

22.

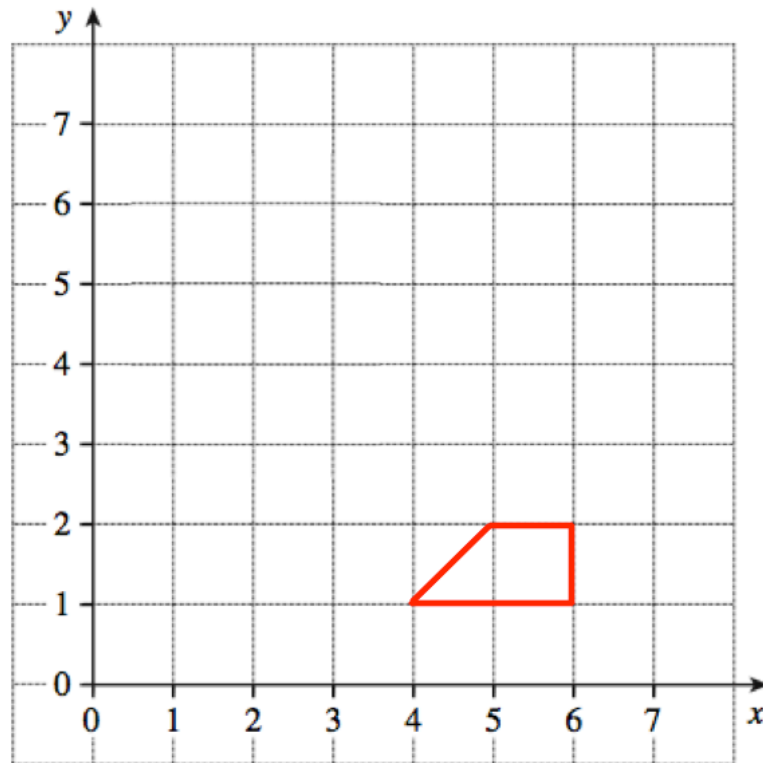

Enlarge the trapezium by scale factor 3, centre (6, 0).

(2)

23. Below is a cylinder with radius 2cm and height 5cm.

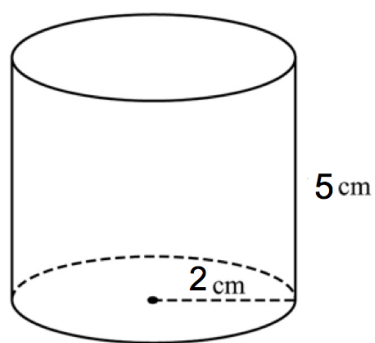

Calculate the volume of the cylinder.

.....cm³
(3)

24. Write down the exact value of $\sin 30^\circ$

.....
(1)

25. A store room measures $4.2\text{m} \times 3\text{m} \times 2\text{m}$
A box measures $60\text{cm} \times 50\text{cm} \times 25\text{cm}$

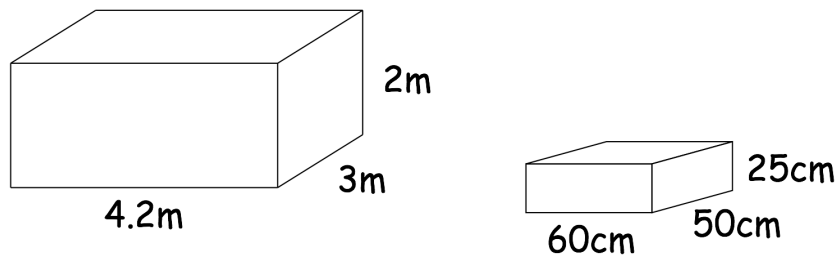

Work out the greatest number of boxes that can be stored in the store room.

.....
(3)

26. A cone has base radius 5cm and perpendicular height 9cm.

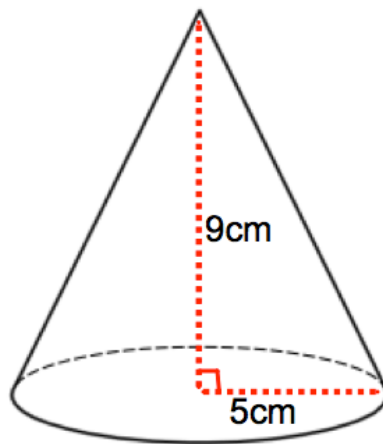

Work out the volume of the cone.

..... cm^3
(3)

27.

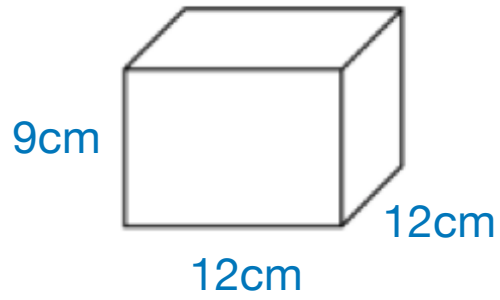

Work out the surface area of this cuboid.
State the units of your answer.

.....
(3)

28. A sphere has a radius of 5cm.

Calculate the surface area of the sphere.

.....
(3)

29. A theatre has 46 rows.
There are 42 seats in each row.



During a show at the theatre, there are 50 empty seats.

Work out how many people are watching the show.

.....
(3)

30. Paul has £10 to buy rulers at 60p each.



What change should he get if he buys as many as possible?

.....
(3)

31. The table below shows how many washing machines and dishwashers were sold by a shop over three months.



	Washing Machines	Dishwashers
April	92	65
May	70	72
June	104	68

Work out how many more washing machines than dishwashers were sold in total over the three months.

.....
(3)

32. Find the missing numbers below.



$$\begin{array}{r} \square 2 4 \\ - 1 5 \square \\ \hline 6 \square 9 \end{array}$$

(2)

33. Holly works out the answer to $135.66 + 193.88$ on a calculator.

Her answer is 329.54

(a) Round her answer to the nearest 10.

.....
(1)

(b) Round her answer to the nearest 100.

.....
(1)

(c) Round her answer to the nearest integer.

.....
(1)

(d) Round her answer to one decimal place.

.....
(1)

34. Use approximations to estimate the value of



$$\frac{596.4 \times 2.06}{0.521}$$

.....
(3)

35. Given



$$a = 11 - 3^2$$

$$b = \frac{60}{2 + 3}$$

$$c = 18 - 3 \times 2 + 1$$

Work out the value of $a + b + c$

.....
(4)

36. Roy is saving money.



In January, he saves £28.65

In February, he saves £14.82

In March, he saves £22.77

Work out how much money Roy has saved in total.

£.....
(2)

37. Megan says “when you square root a number, the answer is always smaller.”



Show she is wrong.

(2)

38. The attendance at Frome United versus Trowbridge Rovers was 8,701.



Of this crowd, five-sevenths supported Frome United.
Calculate how many people did not support Frome United.

.....
(3)

39. Hannah is baking two cakes.



One cake needs $1\frac{1}{3}$ cups of milk.
Hannah has $1\frac{1}{4}$ cups of milk.

How much more milk does Hannah need?

.....cups
(3)

40. Work out



$$1\frac{1}{3} \times 2\frac{2}{5}$$

Give your answer as a mixed number.

.....
(3)

41. Work out



$$\frac{5}{13} \div \frac{2}{3}$$

.....
(1)

42. Write down the reciprocal of 0.35

.....
(1)

43. Express 42 as a percentage of 64

.....%
(2)

44. Joanne sees this special offer in a shop.



Special Offer

Laptop	£465
Printer	£109

Buy both items and receive a 10% discount

Joanne buys both items.

How much does she pay?

£.....
(3)

45. Sarah bought a TV for £250
Three years later she sold it for £180

Work out the percentage loss

.....%
(3)

46. Lauren is given a 12% pay rise.
Her new salary is £24,080

What was Lauren's salary before the pay rise?

£.....
(3)

47. Chris and Molly win money in a competition.
They share the money in the ratio 2 : 3
Molly receives £240.

(a) How much money does Chris receive?

£.....
(2)

(b) How much money did they win in the competition?

£.....
(1)

48. Sophie went to Spain.
She changed £225 into euros (€).

The exchange rate was £1 = €1.62

(a) Change £225 into euros (€).

€.....
(2)

On her return to England, Sophie changed €66 into pounds (£)

The new exchange rate was £1 = €1.50

(b) Change €66 into pounds (£).

£.....
(2)

49. Thomas has a recipe for making Rice Krispie cakes.
The recipe uses 120g of chocolate and 80g of Rice Krispies to make 12 cakes.

(a) How much chocolate should Thomas use to make 30 cakes?

.....g
(2)

(b) What is 120g out of 200g expressed as a percentage?

.....%
(1)

50. A number, n , is rounded to 1 decimal place.
The result is 1.3

Using inequalities, write down the error interval for n .

.....
(2)

51. Florence buys a car for £17100

She pays a deposit of £6750 and pays the rest in equal monthly payments.
Each monthly payment is £230

How many monthly payments does Florence make?

.....
(3)

52. A supermarket sells Baked Beans in two different size cans.



215g

40p



395g

74p

Which size can is the best value for money?
You must show all your working.

(4)

53. 100 students study one language at a college.

Some students study French.

Some students study Spanish.

The rest of the students study German.

54 of the students are in Year 12.

20 of the 29 students who study Spanish are in Year 13.

31 students study German.

15 Year 13 students study French.

Work out the number of Year 12 students who study German.

54. The pictogram shows the amount of money raised by students in some tutor groups at a school.

Key ○ = £10

Tutor group		Raised
S	○ ○ ○ ○ ○ ○	
T	○ ○ ○	
E		£45
P	○ ○ ○ ◐	

- (a) Complete the raised column.

(2)

- (b) Complete the pictogram for tutor group E.

(2)

- (c) How much money was raised altogether?

£.....
(1)

55. Miss Jackson asked the 32 students in her tutor group which language they study.

Each student studies one language only.

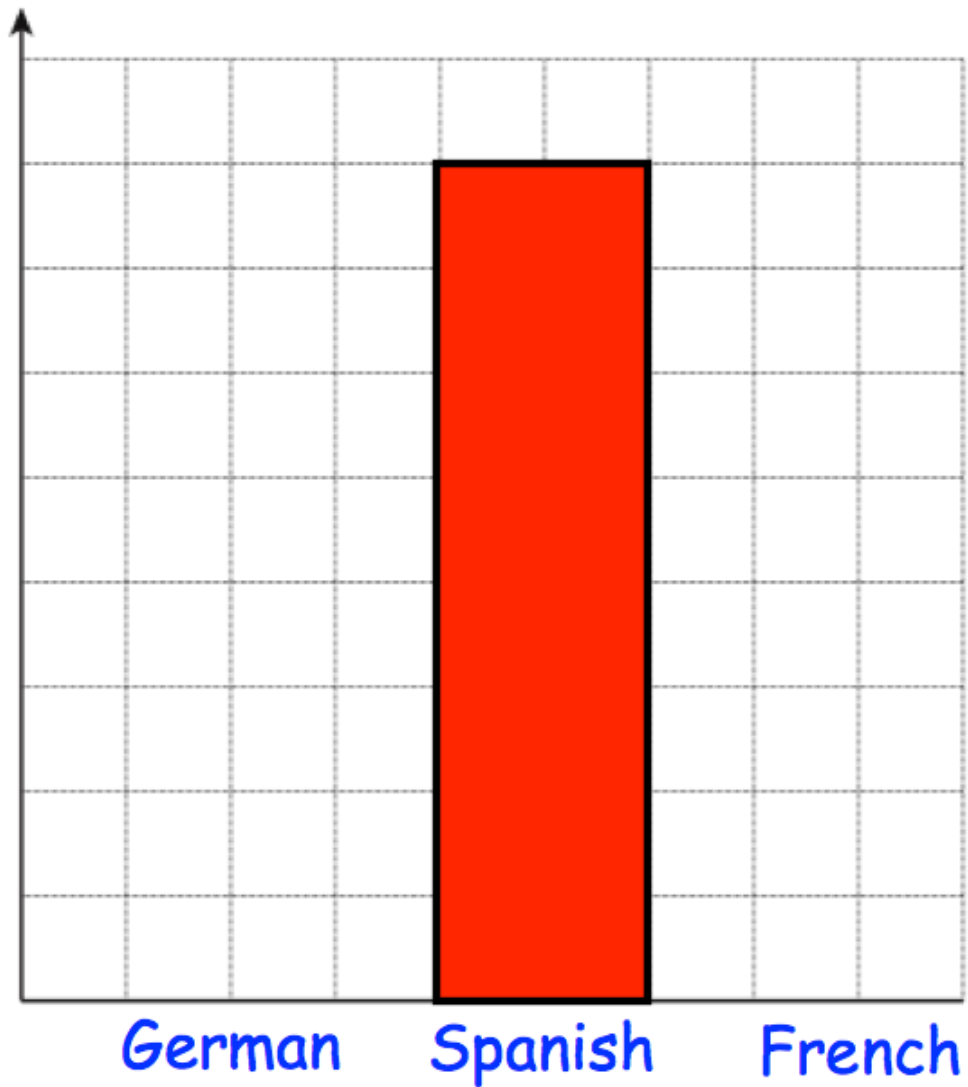

Half of the students in the tutor group study Spanish.
Six more students study German than French.

Complete the bar chart.

56. A rugby team can win, draw or lose a match.
The table shows the probabilities of each result.

Result	Win	Draw	Lose
Probability	0.4	0.35	

- (a) Calculate the missing probability in the table.

.....
(2)

Each win is worth 2 points.
Each draw is worth 1 point.
Each loss is worth 0 points.
The rugby team plays 20 games in a season.

- (b) Work out how many points the rugby team should receive in one season.

.....
(3)

57. William is going to attend a two day summer camp at his local leisure centre. He can take part in one activity on Monday and one activity on Tuesday.

Monday	Tuesday
Golf	Ice-skating
Football	Swimming
Rugby	Dodgeball
Hockey	Basketball

List all the possible combinations of activity he can take part in.

.....

.....

.....

.....

.....

.....

(2)

-
58. 5 Year 10 students and 45 Year 11 students sit a test.

The mean mark for the whole group is 70
The mean mark for the Year 11 students is 72

Work out the mean mark for the Year 10 students.

.....
(2)

59. Timothy asked 30 people how long it takes them to get to school. The table shows some information about his results.

Time (t minutes)	Frequency
$0 < t \leq 10$	2
$10 < t \leq 20$	8
$20 < t \leq 30$	12
$30 < t \leq 40$	7
$40 < t \leq 50$	1

Work out an estimate for the mean time taken.

.....minutes
(4)

60. There are 80 students in year 11.

9 students study French and German.
35 students only study French
2 students do not study French or German.

- (a) Complete the Venn diagram

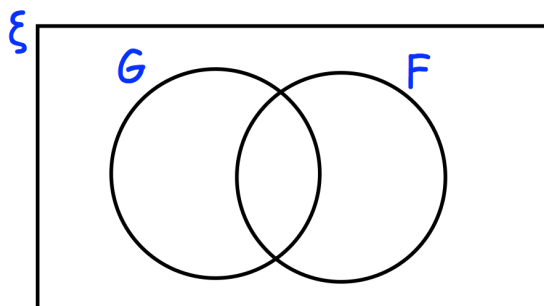

(2)

- (b) Work out how many students study only German.

.....
(1)

62. An airplane has economy and first class seating.
There are s seats in each row in economy.
There are t seats in each row in first class.
There are 8 rows in first class and 18 rows in economy.

Write down an expression, in terms of s and t , for the number of seats on the airplane.

.....
(2)

63. Simplify $9h + 5k + 4h - 8k$

.....
(2)

64. Here is a pattern of dots

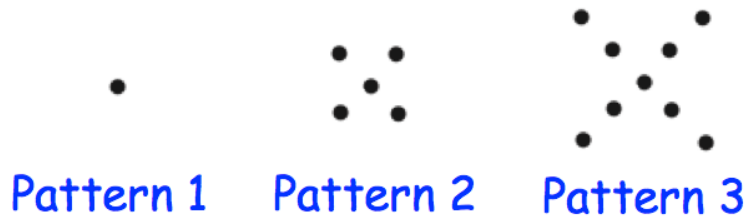

(a) Continue the pattern to show Pattern 4

(2)

(b) How many dots will there be in Pattern 6?

.....
(1)

(c) Which pattern will use 77 dots?

.....
(1)

(d) Explain why there will **not** be a pattern that uses 200 dots.

.....
.....
(1)

65. Circle the geometric progression.

11, 9, 7, 5 ...

1, 4, 9, 16 ...

11, 21, 31, 41 ...

1, 4, 16, 64 ...

.....
(1)

66. Work out the n th term for this sequence

8 17 26 35 44

.....
(2)

67. Expand and simplify $(w - 3)(w - 8)$

.....
(2)

68. Factorise

$$15y + 20$$

.....
(2)

69. (a) Factorise $x^2 + 2x - 24$

.....
(2)

(b) Factorise $x^2 - 25$

.....
(1)

70. Solve $4y + 1 = 6y + 26$

$y = \dots\dots\dots$
(2)

71.

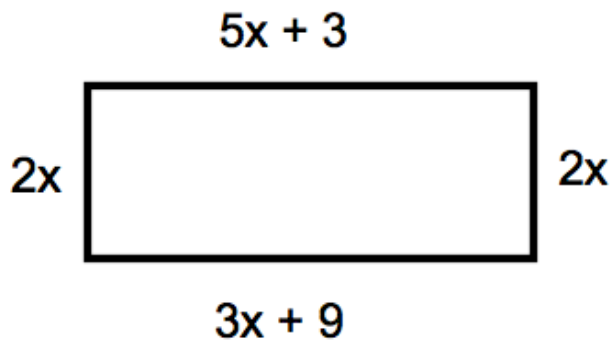

The diagram shows a rectangle. The sides are measured in centimetres.

(a) Explain why $5x + 3 = 3x + 9$

.....
.....
(1)

(b) Solve $5x + 3 = 3x + 9$

$x = \dots\dots\dots$ cm
(2)

(c) Calculate the perimeter of the rectangle.

.....cm
(2)

72. On the grid, draw $x + 2y = 6$ for values of x from -2 to 2 .

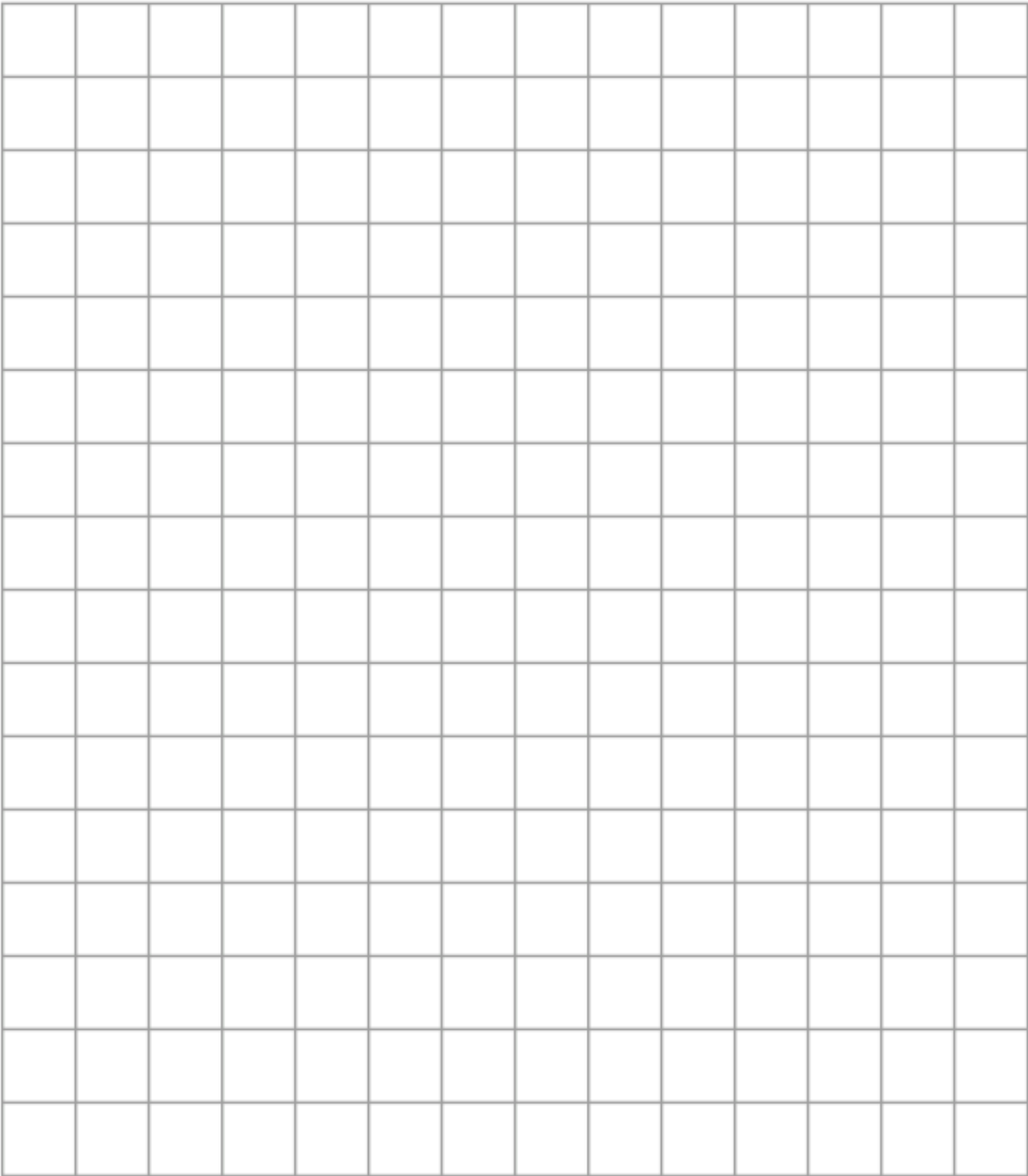

73. The graph below shows the depth of water in a container.

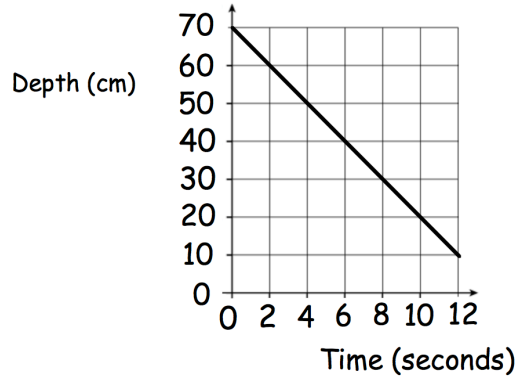

(a) Write down the gradient of the line

.....
(1)

(b) What does the gradient of the line represent?

.....
(1)

74. Make w the subject of the formula

$$y = 3w - a$$

$w =$
(2)

75. Solve the simultaneous equations

$$2x + 4y = 26$$

$$3x - y = 4$$

Do not use trial and improvement

$x =$ $y =$
(3)

76. (a) Complete the table of values for $y = x^2 - 3x$

x	-2	-1	0	1	2	3	4
y	10		0	-2		0	

(2)

(b) On the grid, draw the graph of $y = x^2 - 3x$ for the values of x from -2 to 4.

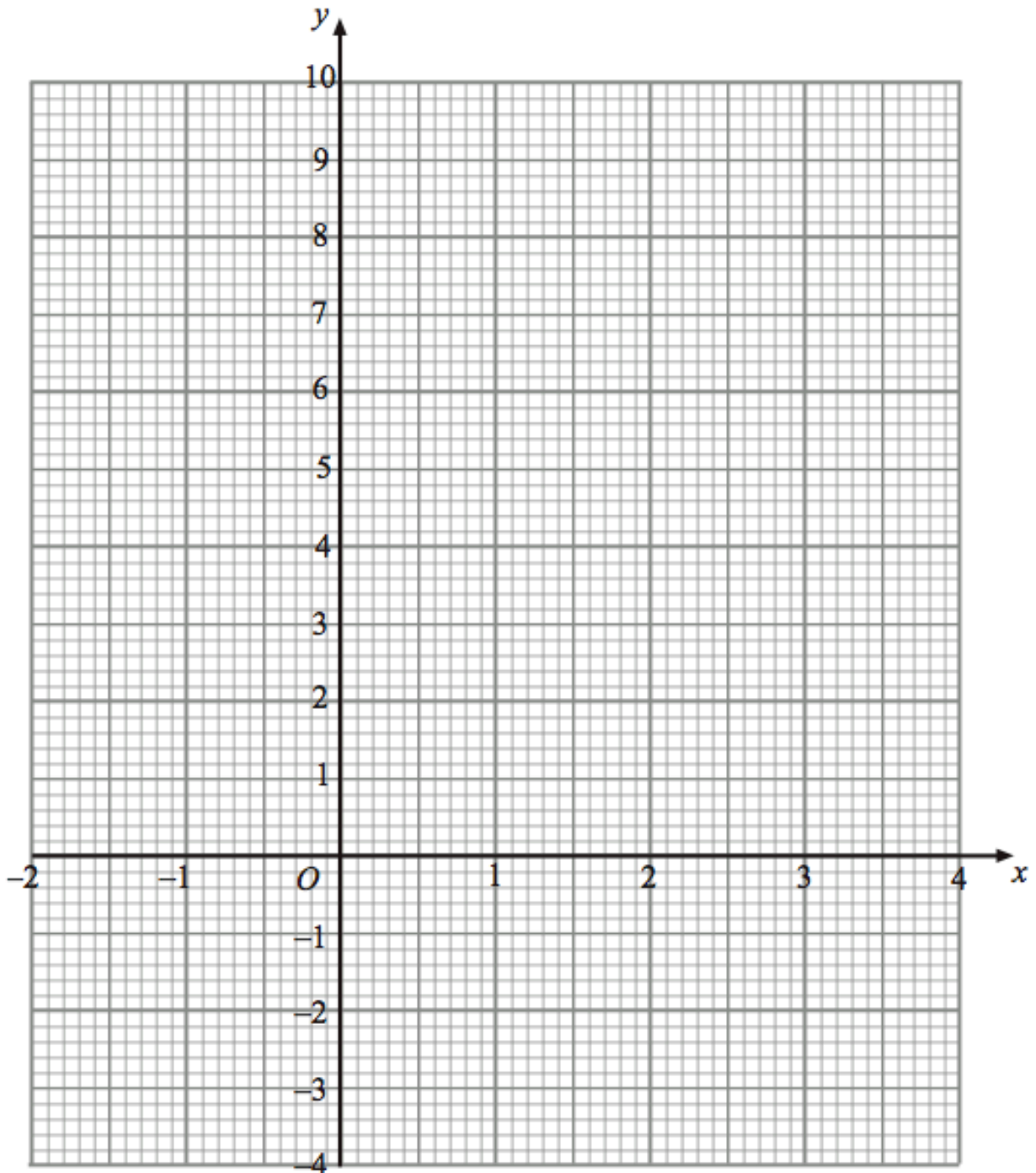

(2)

77. The perimeter of a parallelogram is 17cm.
The length of each long side is 5cm.



Work out the length of each short side.

.....cm
(2)

78. The mass of a 2p coin is 7g.
Find the mass of £6 worth of 2p coins.
Give your answer in kilograms.

.....kilograms
(4)

79. A glass contains water.
Below are four estimates of the amount of water in the glass.
Circle the most appropriate estimate.

25ml 25L 250ml 2.5L

(1)

80. The distance chart below shows the distance, in miles, between some towns and cities.

Cambridge			
54	Ipswich		
64	45	Norwich	
43	82	78	Peterborough

(a) Write down the distance between Ipswich and Peterborough.

..... miles
(1)

(b) Write down the distance between Norwich and Cambridge.

..... miles
(1)

(c) Write down the names of the places that are 78 miles apart

..... and.....
(1)

81. Bethany drove to a family meal and then back home.
The meal was at a restaurant that is 70 kilometres from her home.

Bethany left home at 10:00 and arrived at the restaurant at 11:30.
She stayed at the family meal for 2 hours.
Bethany then drove home at a speed of 35 kilometres per hour.

Show this information on the distance-time graph.

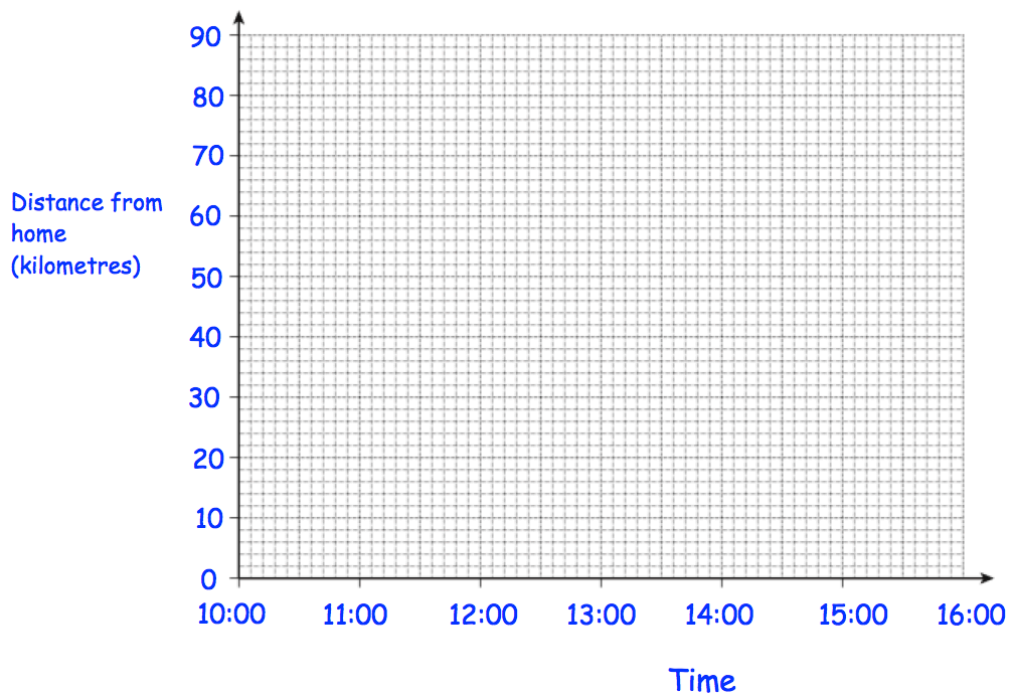

(3)

-
82. An object is placed on a table.
It exerts a force of 22 newtons on the table.

The pressure on the table is 500 newtons/m²

Calculate the area of the crate that is in contact with the table.
Include suitable units.

.....
(3)

83.

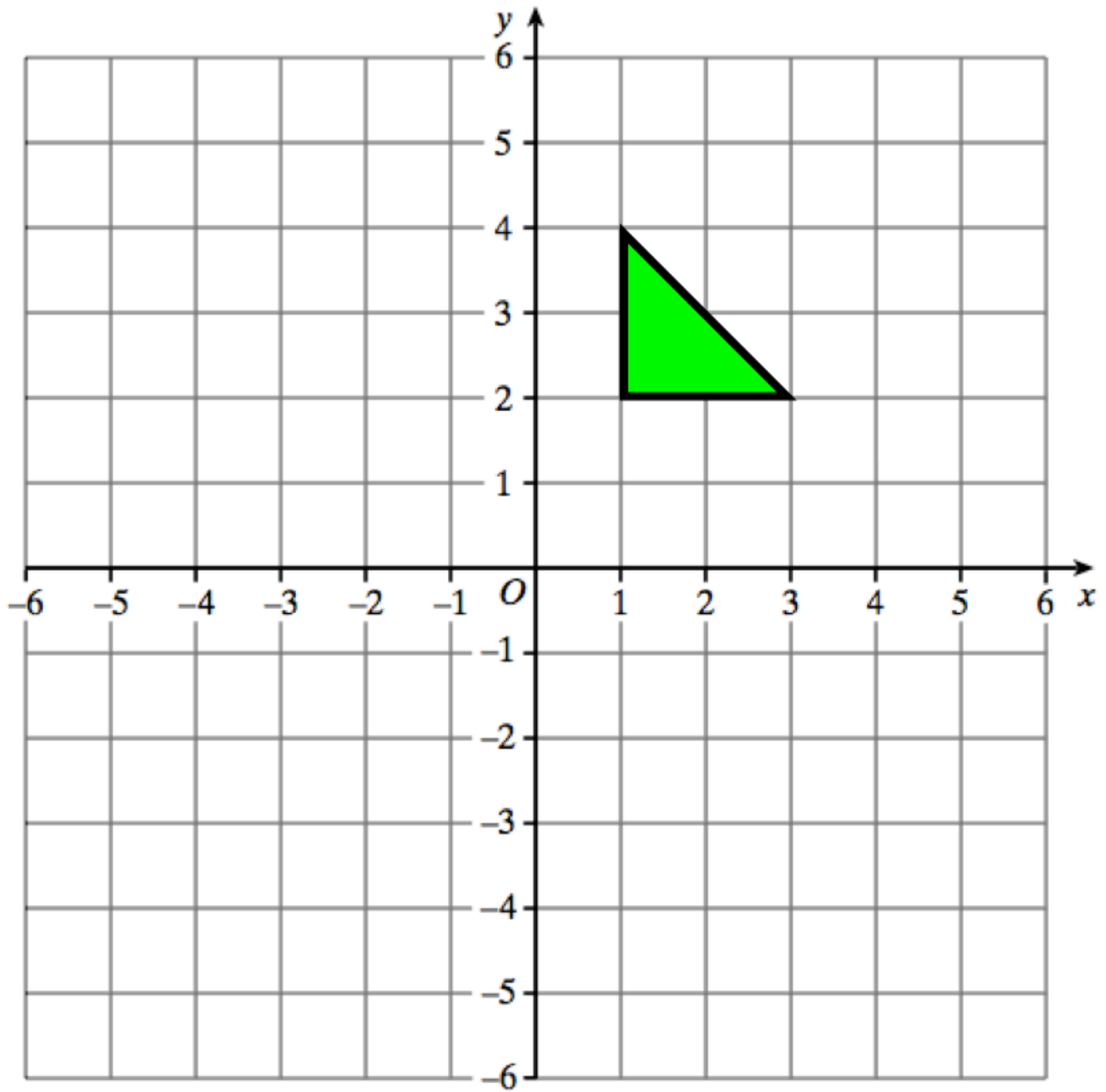





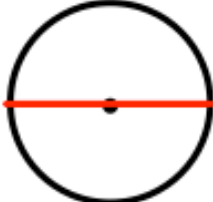

Reflect the triangle in the line $y = -1$
Label the new triangle B.

(2)

84. Here are 6 diagrams and 6 labels.
In the diagram the centre of the circle is shown with a dot.

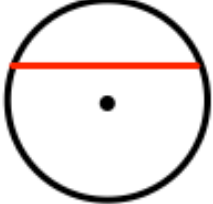
Match each diagram to its label.
One has been done for you.

Label	Diagram
Circle and radius	
Circle and segment	
Circle and arc	
Circle and diameter	
Circle and tangent	
Circle and chord	

85. The diagram shows a rectangle with a circle cut out.

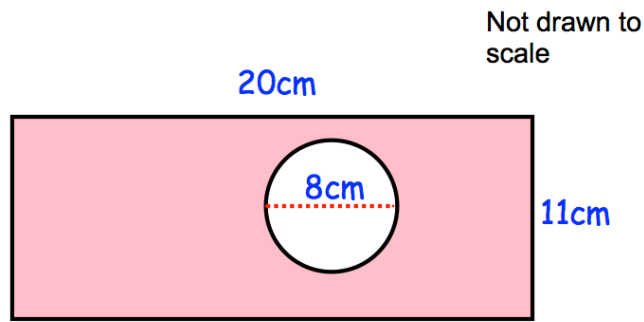

The rectangle has length 20cm and width 11cm.
The circle has diameter 8cm.

Work out the shaded area.
Give your answer correct to 2 decimal places.

.....cm²
(4)

86.

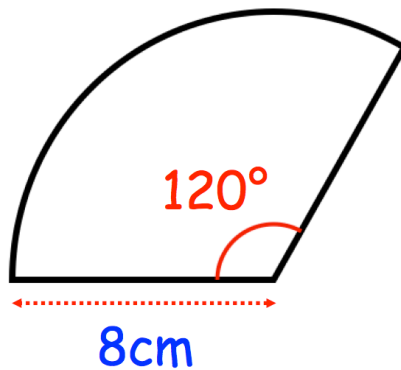

Calculate the area of the sector.

.....cm²
(2)

87.

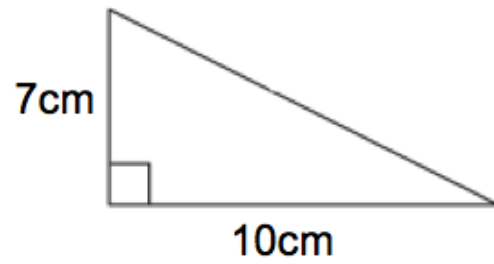

Shown is a right-angled triangle.

Work out the perimeter of the triangle

..... cm
(4)

88. Triangle ABC has a right angle.
Angle BAC is 25°
AC = 12.5cm

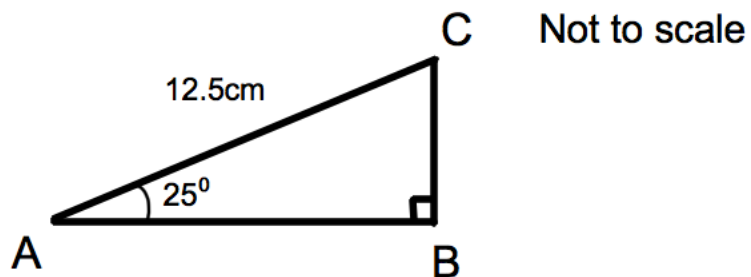

Calculate the length of AB

.....cm
(3)

89.

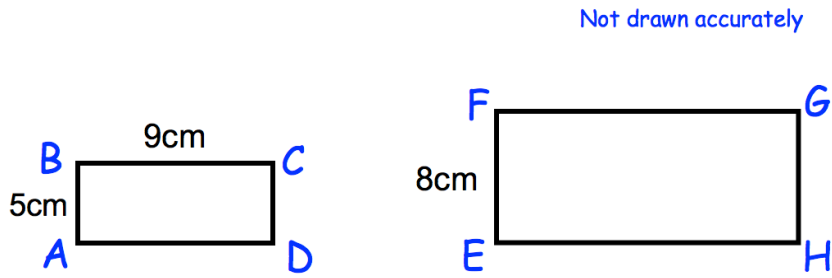

Rectangles $ABCD$ and $EFGH$ are similar.

$$AB = 5\text{cm}$$

$$BC = 9\text{cm}$$

$$EF = 8\text{cm}$$

Work out the length of FG .

.....cm
(2)

90. Shown below are six triangles that are not drawn accurately.

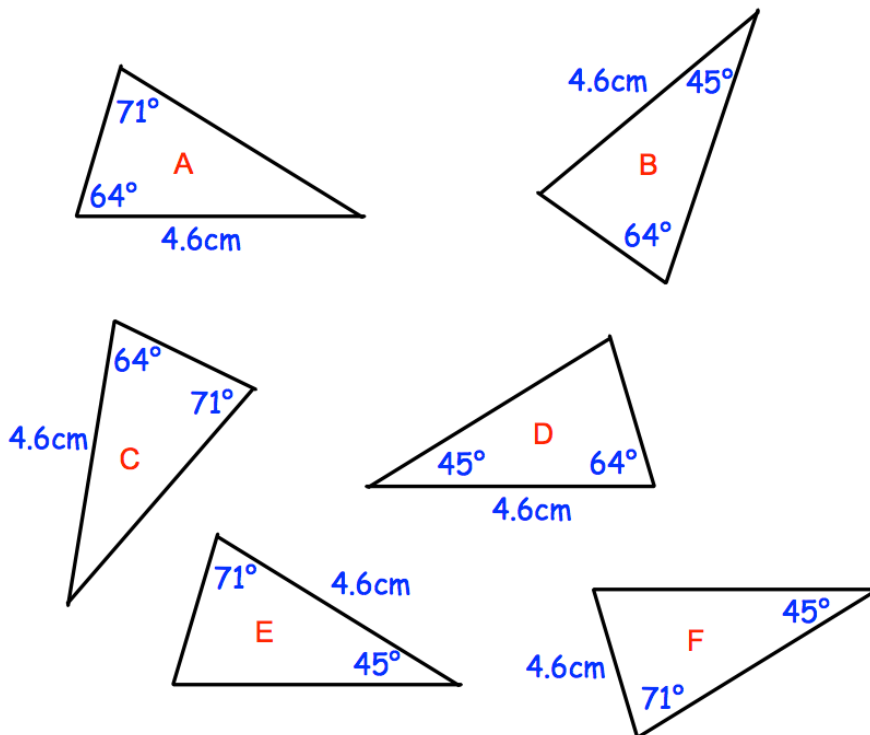

Which two triangles are congruent to triangle A ?

..... and

(2)

91. Write the following numbers in order of size.
Start with the largest number.

0.7 0.09 0.269 0.47 0.9

.....
(1)

92. (a) Write down two multiples of 7.

..... and
(1)

(b) Write down two multiples of 9.

..... and
(1)

(c) Write down a number which is a multiple of both 7 and 9.

.....
(1)

93. Write down all the prime numbers between 10 and 20.

.....
(2)

94. From the list of numbers

3 6 8 14 16 28 41 64

write down the cube root of 27.

.....
(1)

95. Tilly the dog barks every 9 seconds.
Billy the dog barks every 12 seconds.
They both bark at the same time.

After how many seconds will they next bark at the same time?

.....seconds
(2)

96. Calculate 3^6

.....
(1)

97. Work out



$$10^{-2}$$

Give your answer as a decimal.

.....
(2)

98. Complete the table.



Fraction	Decimal	Percentage
		85%
	0.12	
$\frac{23}{25}$		

(4)

99. Fiona leaves £1600 in the bank for four years.
It earns compound interest of 4% each year.

Calculate the total amount Fiona has in the bank at the end of the four years.

£.....
(3)

100. Work out the difference between -3°C and 4°C



..... $^{\circ}\text{C}$
(1)

At 5am the temperature is -6°C

By 2pm the temperature went up by 9°C

From 2pm to 11pm the temperature went down by 15°C

- (b) Work out the temperature at 11pm

..... $^{\circ}\text{C}$
(2)

101. Here are four digits.

9 4 7 5

(a) Use two of these digits to make the largest possible two-digit number.

.....
(1)

(b) Use all four of these digits to make the four-digit number closest to 5000.

.....
(1)

102. Sophie asks 20 of her friends to choose their favourite sport.

Their replies are

Rugby	Football	Rugby	Hockey	Cricket
Football	Football	Rugby	Hockey	Football
Rugby	Cricket	Hockey	Football	Football
Football	Rugby	Football	Football	Rugby

Complete the tally and the frequency columns in the table below.

Sport	Tally	Frequency
Rugby		
Football		
Hockey		
Cricket		

(2)

103. Below is a line graph that shows the population of a village.

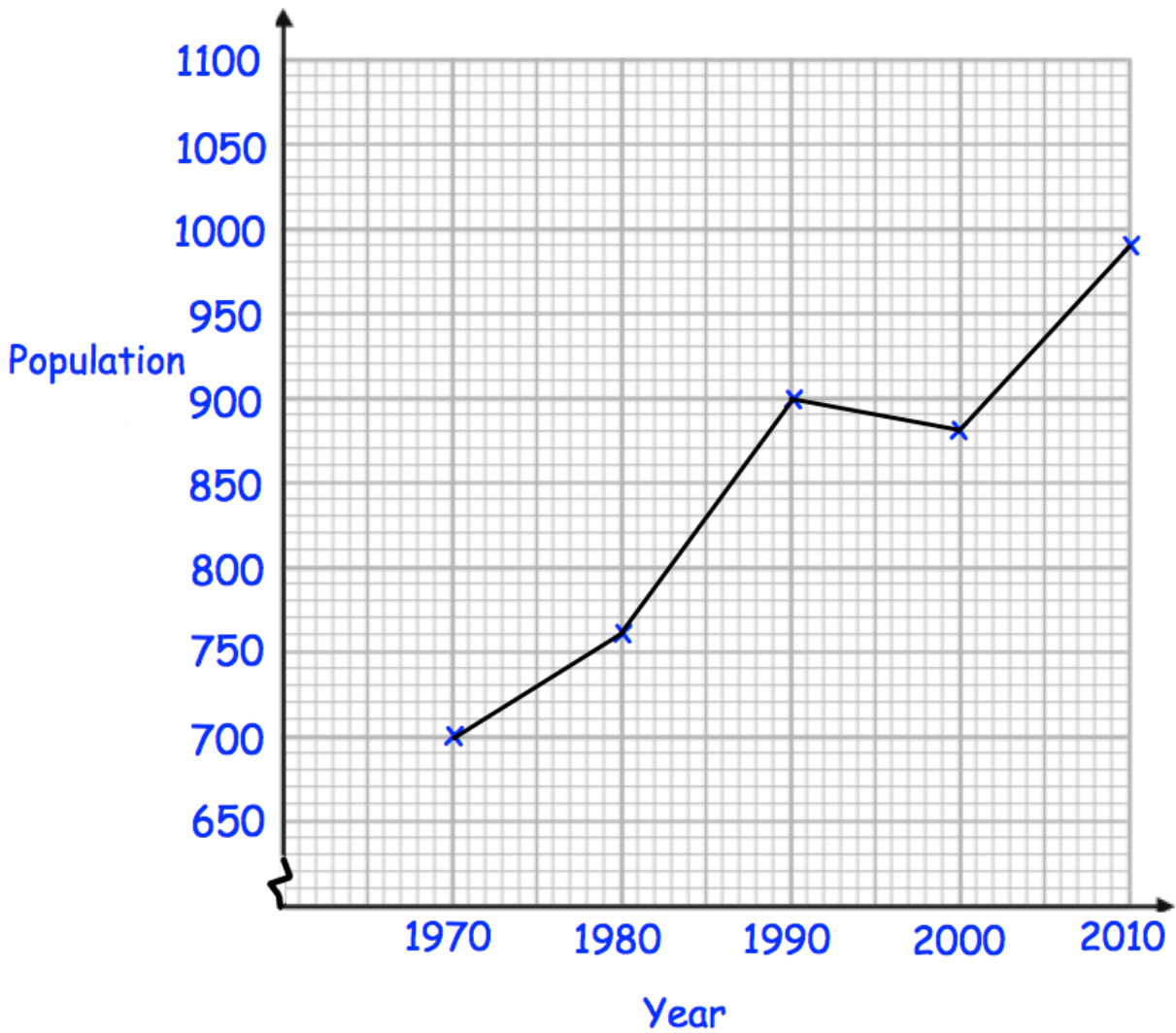

(a) What was the population in 1980?

.....
(1)

(b) In which year was the population 700?

.....
(1)

The population increased by 120 by 2020.

(c) Work out the population in 2020.

.....
(2)

104. A three-sided spinner is labelled A, B and C.

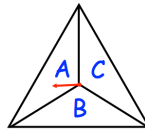

The spinner is spun and the frequency the letter A is recorded every 10 spins. The table below shows this information.

Spins	10	20	30	40
Frequency of an A	5	12	21	26

(a) Complete plot the relative frequencies on the graph below.

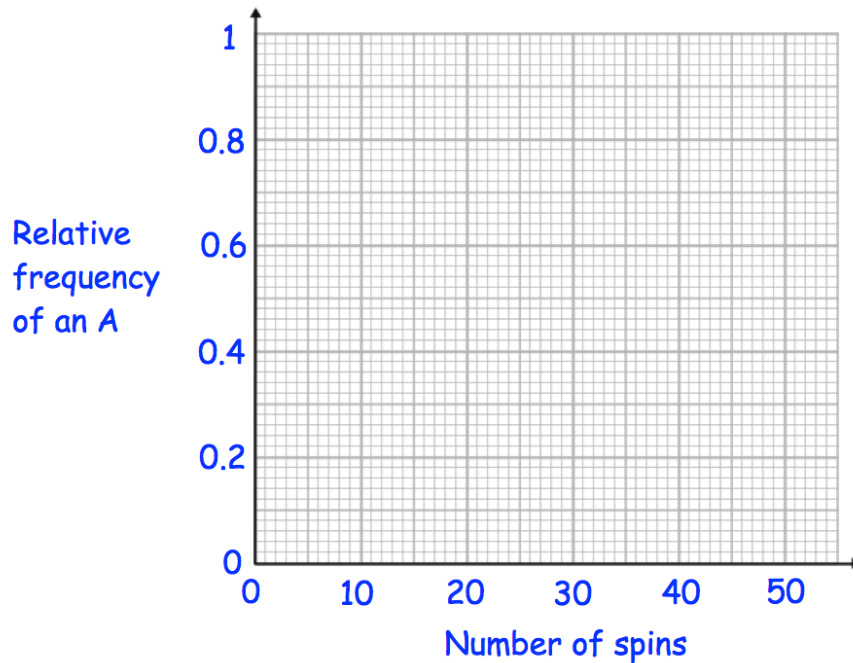

(3)

(b) Neil says the relative frequency after 50 spins is 0.8
Explain why Neil must be wrong

.....

.....

(2)

105. The table shows the number of pages in 100 books.

Number of pages, x	Frequency
$0 < x \leq 100$	7
$100 < x \leq 200$	25
$200 < x \leq 300$	40
$300 < x \leq 400$	12
$400 < x \leq 500$	16

Write down the modal class interval.

.....
(1)

106. A manager recorded how long each customer spent in his supermarket. The table shows his results.

Time, t (minutes)	Frequency
$0 < t \leq 10$	24
$10 < t \leq 20$	31
$20 < t \leq 30$	50
$30 < t \leq 40$	35
$40 < t \leq 50$	60

Which class interval contains the median?

.....
(1)

107.

Name	Price (£)	Mass (kg)	Thickness (cm)	Battery (minutes)
Epic	£799	1.23	1.89	690
Bell	£1249	1.2	1.52	650
Lemon	£1599	1.37	1.49	720
HB	£799	1.28	1.7	740
Lazer	£1049	1.35	1.66	660

(a) Which laptop is the thickest?

.....
(1)

(b) How much longer does the HB battery last than the Bell battery?

.....
(1)

108.

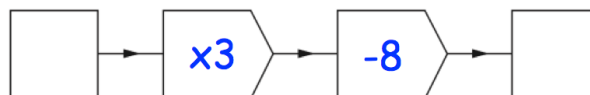

(a) Work out the output, when the input is 10.

.....
(1)

(b) Work out the input, when the output is 13.

.....
(1)

(c) If the input is the same as the output, work out the input.

.....
(1)

109.

(a) Simplify

$$m^9 \times m^2$$

.....
(1)

(b) Simplify

$$\frac{m^{10}}{m^2}$$

.....
(1)

(c) Simplify

$$(m^3)^6$$

.....
(1)

110. Solve the inequality $5x + 11 \geq 2$

.....
(2)

111.

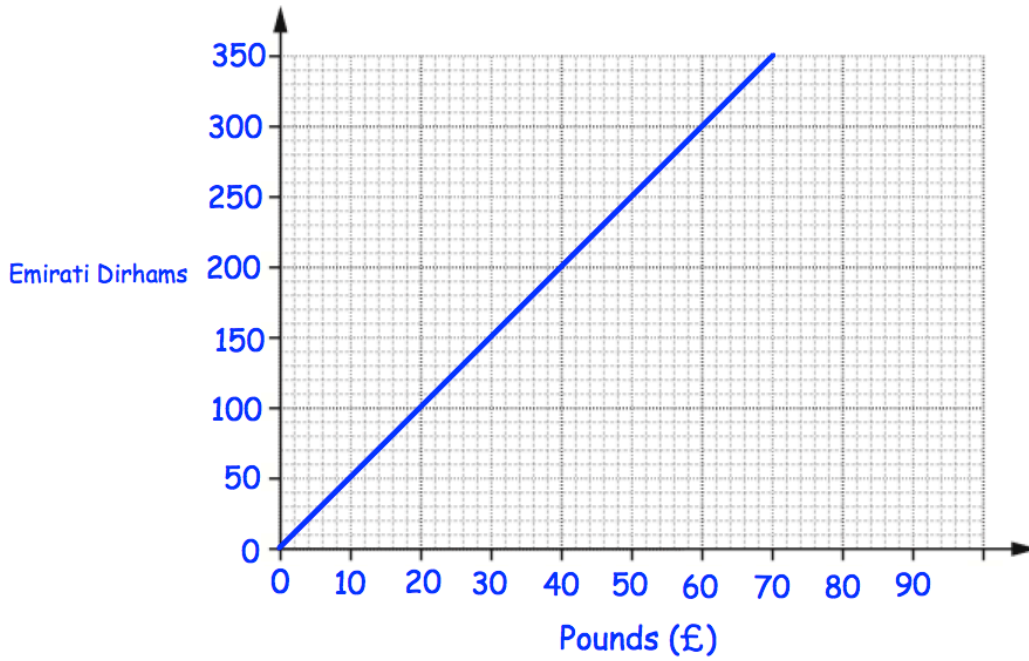

Tom wants to buy a camera.
In London the camera costs £380.
In Abu Dhabi the camera costs 2000 Dirhams.

In which city is the camera cheaper and by how much?
Give your answer in pounds.

City:..... £.....

(1)

112. A straight line L is shown on the grid.

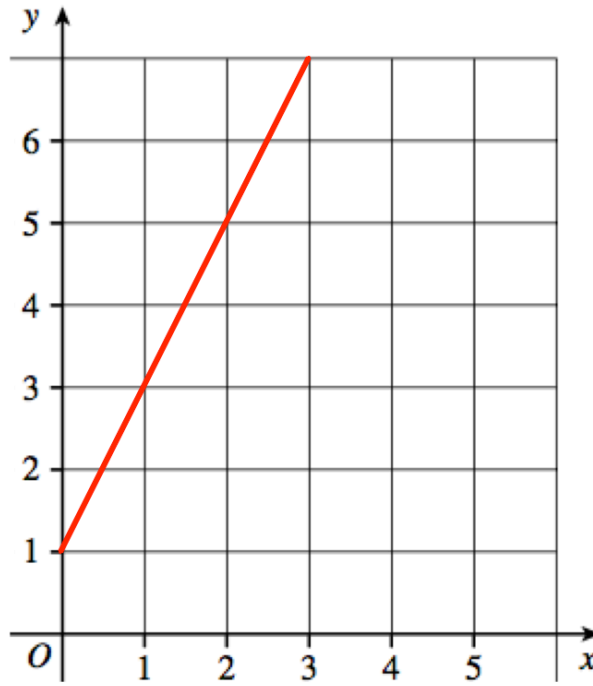

Work out the equation of line L

.....
(3)

113. A is the point with coordinates (1, 4).
B is the point with coordinates (7, 22).

Find the gradient of AB.

.....
(2)

114.

(a) Complete the table of values for $y = x^3 - 2x + 3$

x	-2	-1	0	1	2
y					

(2)

(b) On the grid, draw the graph of $y = x^3 - 2x + 3$ for the values of x $-2 \leq x \leq 2$

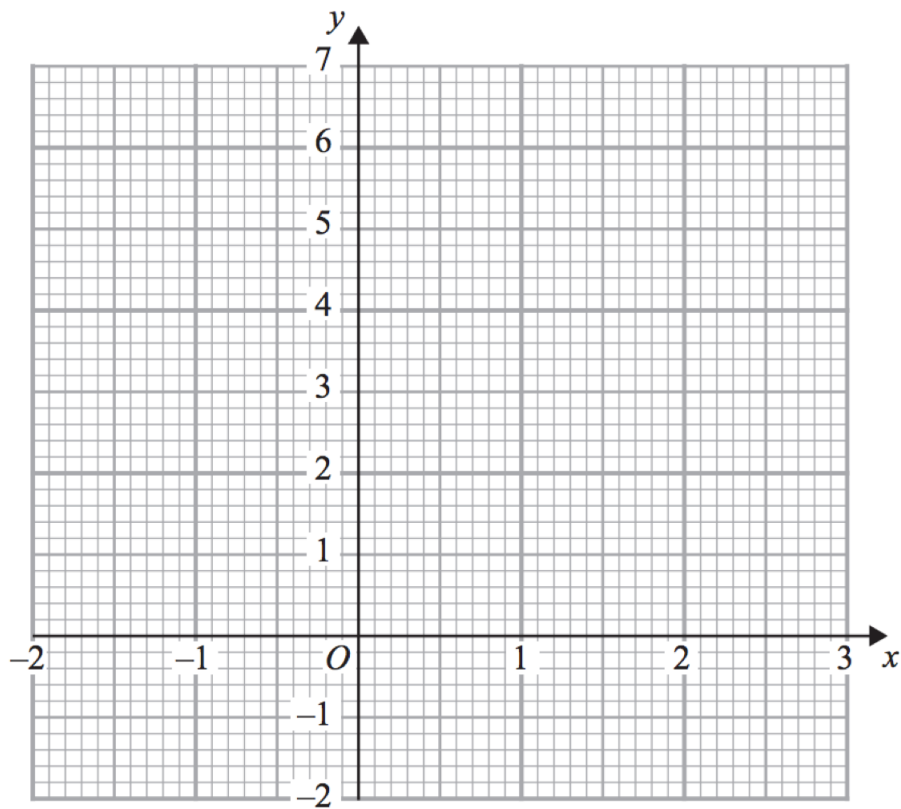

(2)