

Paper 3 Preparation Paper

AQA Higher



Corbettmaths

The topics highlighted in green (and bold) are the starred topics from the Paper 3 Revision Checklist

Guidance

1. Check your answers seem right.
2. Always show your workings
3. Take your time when working through this collection of questions

Revision for this test

1. Two shops sell the same type of perfume.
A 100ml bottle of perfume normally costs £40.

Shop A

50% extra free → 150ml



Only £40

Shop B

Buy one get the second
HALF PRICE



Normal price £40
for 100ml

£60 for 200ml

Rebecca says that both offers give the same value for money.
Is she correct? Show your working.

No

Shop A $4000 \div 150 = 26.6p$ per ml

Shop B $6000 \div 200 = 30p$ per ml

Shop A is better value

(5)

2. The table below shows information about the monthly rent of an apartment and the distance of the apartment from a city centre, in miles.

Distance (miles)	3.2	1.5	5.7	8.2	0.7	0.9	4.4	5.8	9.3	0.4
Monthly rent (£)	340	420	250	190	500	470	300	260	170	510

- (a) Plot the data on the scatter graph below.
Clearly label your axes.

(3)

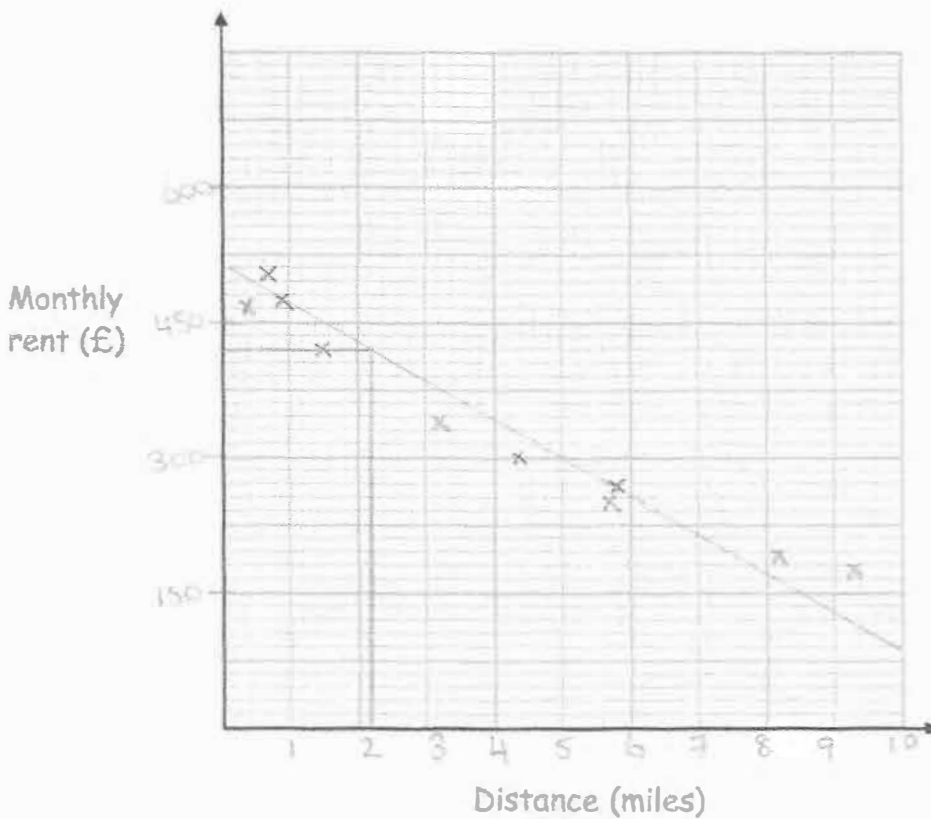

- (b) Describe the relationship between the distance from the city centre and the monthly rent.

The further away from the centre, the less the rent.

(1)

An apartment is 2.2 miles from the city centre.

- (c) Find an estimate for the monthly rent

£ 420

(2)

3. The population of England is 5.301×10^7
 The number of people who live in London is 8.308×10^6

What percentage of the population of England live in London?

$$\frac{8.308 \times 10^6}{5.301 \times 10^7} \times 100$$

.....
 15.67%

(2)

4.

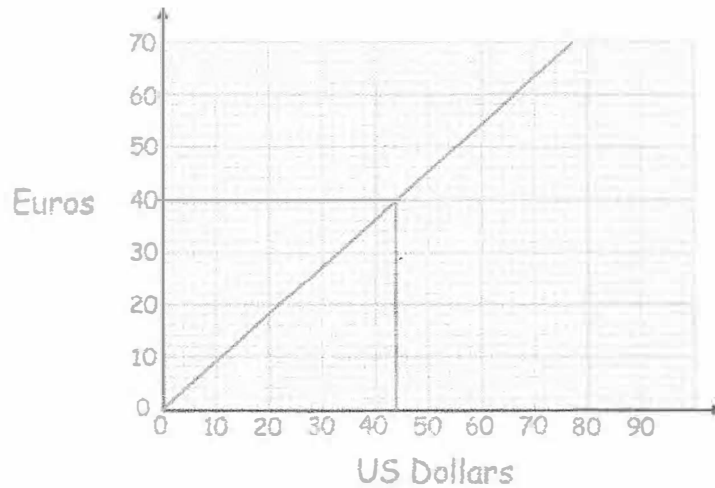
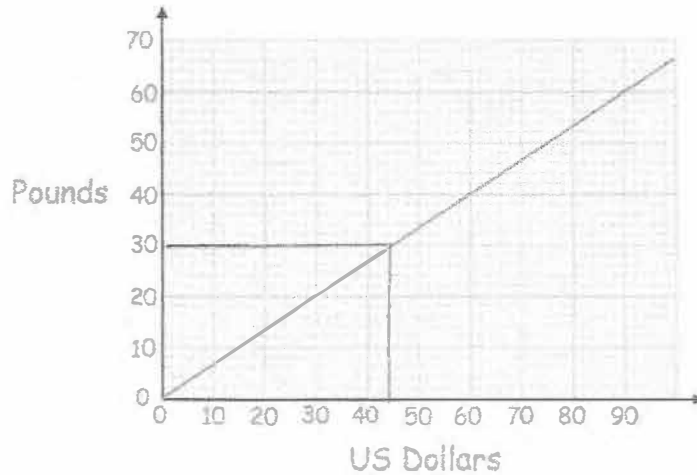

(a) Change £30 into Euros.

.....40.....Euros
 (2)

(b) Change 200 Euros into Pounds (£)

$$\begin{aligned} \text{€ } 40 &= \text{£ } 30 \\ \times 5 & \quad \times 5 \\ \text{€ } 200 &= \text{£ } 150 \end{aligned}$$

.....£ 150.....
 (2)

5. Use a ruler and compasses to construct the perpendicular to the line segment AB that passes through the point P.

You must show all construction lines.

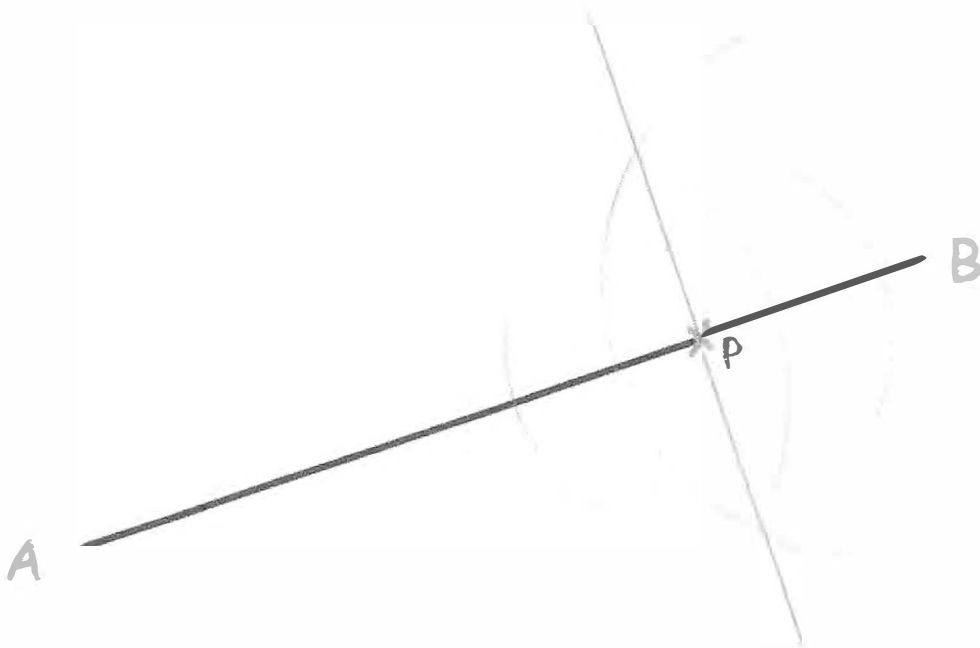

(2)

6.

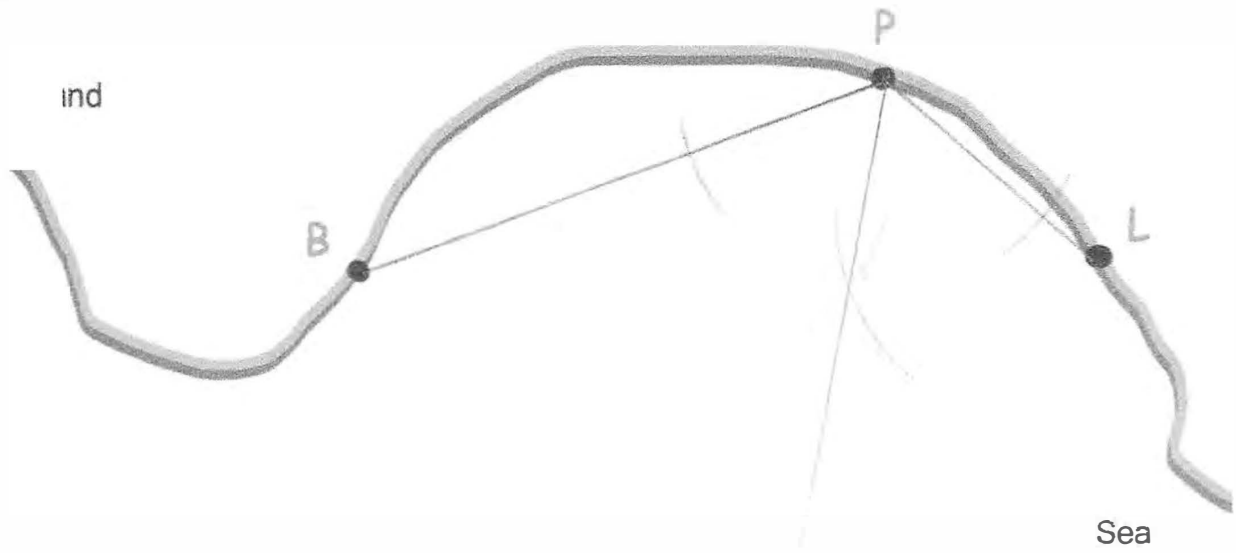

A yacht leaves the port, P, on a course that is an equal distance from PB and PL.

Using ruler and compasses only, construct the course on the diagram.
You must show your construction arcs.

(2)

7. A shape has been made from joining a rectangle, trapezium and triangle.

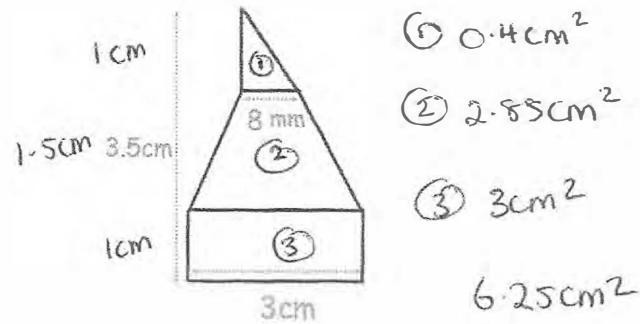

The height of the shape is 3.5 cm.
 The ratio of the height of the rectangle to the height of the trapezium to the height of the triangle is 2:3:2. = 7 parts
 Calculate the area of the shape.

$$3.5 \div 7 = 0.5$$

$$0.5 \times 2 = 1$$

$$0.5 \times 3 = 1.5$$

$$0.5 \times 2 = 1$$

$$(1) \frac{1}{2} \times 0.8 \times 1 = 0.4 \text{ cm}^2$$

$$(2) \frac{1}{2} (0.8 + 3) \times 1.5 = 2.85$$

$$(3) 1 \times 3 = 3$$

6.25 cm^2
 (3)

8.

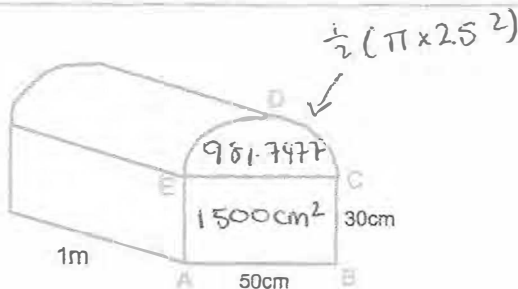

Shown above is a ~~prism~~ ^{trunk} that is 1 m long.
 ABCDE is the cross-section of the ~~prism~~ ^{trunk}.
 ABCE is a rectangle and CDE is a semi-circle.
 Calculate the volume of the ~~prism~~ ^{trunk}.
 Give your answer correct to 1 decimal place.

$$2481.74 \dots \times 100$$

$$248174.8 \text{ cm}^3$$

248174.8 cm^3
 (4)

9. The swimming pool in a leisure centre is shown below.

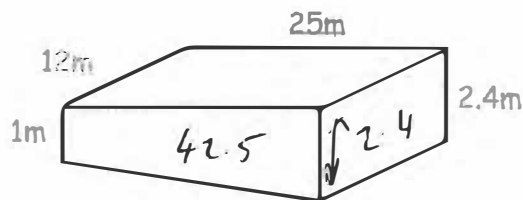

The length of the swimming pool is 25m and the width is 12m.
The depth of the shallow end is 1m and the depth of the deep end is 2.4m.
Given $1\text{m}^3 = 1000$ litres
Work out how much water, in litres, the swimming pool holds.

$$\frac{1}{2} (1 + 2.4) \times 25 = 42.5$$
$$42.5 \times 12 = 510\text{m}^3$$

$$510 \times 1000$$

$$\dots\dots\dots 510000 \text{ litres}$$

(4)

10. Factorise $100 - 81x^2$

$$(10 - 9x)(10 + 9x)$$

.....
(2)

11. A teacher surveys 64 children on how they travelled to school.

20 of the students were in Year 7.

The teacher surveyed 30% more students in Year 9 than in Year 7.

The rest of the students surveyed were in Year 11.

75% of the students in Year 7 walked to school.

8 more students in Year 9 walked to school than did not walk.

Out of students surveyed, more Year 11 students walked to school than Year 9 students.

One of these students is picked at random

Write down the probability that the student chosen will walk to school.

	yr 7	yr 9	yr 11	Total
walk	15	17	18	50
Other	5	9	6	14
Total	20	26	18	64

25
32

.....
(4)

12. Barry won £420 in a competition.

The pie chart shows how he shared the money with his brother, Nick, and sister, Helen.

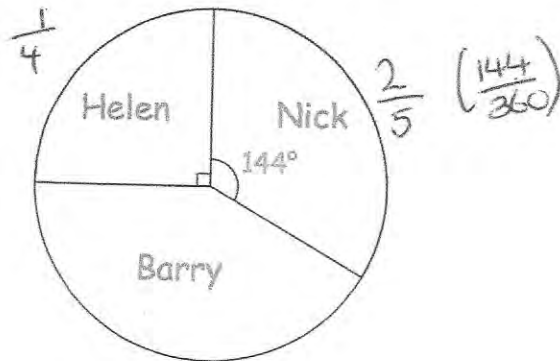

With the money Barry kept for himself, he spent some and invested some, in the ratio 5:2. \Rightarrow 7 parts

How much money did Barry invest?

$$\text{Helen: } \frac{420}{4} = \pounds 105$$

$$\text{Nick: } \frac{2}{5} \text{ of } \pounds 420 = \pounds 168$$

$$\text{Barry: } 420 - (105 + 168) = \pounds 147$$

$$\pounds 147 \div 7 = 21$$

$$21 \times 2 = \pounds 42$$

£42
(4)

13. The diagram shows a cone.
 The vertical height is 20cm.
 The radius of the base is 4.5cm.
 The slant height is y

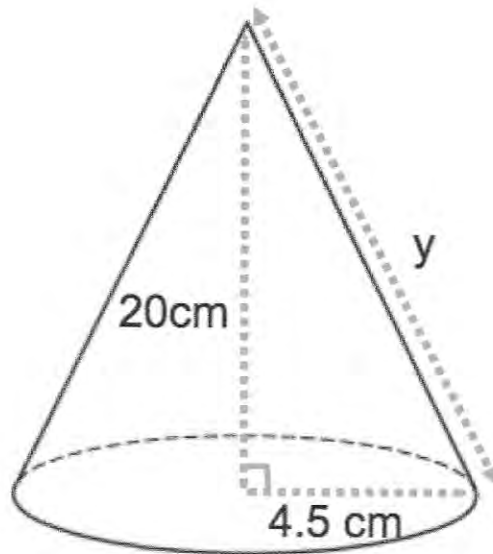

- (a) Work out the value of y .

$$20^2 + 4.5^2 = 420.25$$

$$\sqrt{420.25}$$

$$\dots\dots\dots 20.5 \text{ cm}$$

(3)

- (b) Work out the surface area of the cone.
 Give your answer to one decimal place.

$$\pi \times 4.5 \times 20.5 = 289.8119$$

$$\pi \times 4.5^2 = 63.6172$$

$$\dots\dots\dots 353.4 \text{ cm}^2$$

(3)

14. Trains to Portadown leave a train station every 28 minutes.
Trains to Portrush leave a train station every 16 minutes

A train to Portadown and a train to Portrush both leave the train station at 8am.

When will a train to Portadown and a train to Portrush both leave the train station at the same time?

28 56 84 112
16 32 48 64 80 96 112

9:52 am

.....
(3)

15. Simplify

$$\frac{10m^5n^4}{2m^2n}$$

$5m^3n^3$

.....
(2)

16. Bethan owns 10 shops and 5 restaurants. She is going to visit three of her businesses and writes her list in order. The order will be:

shop, restaurant, shop
or
restaurant, shop, restaurant

How many different lists can Bethan write?

$$10 \times 5 \times 9 = 450$$

or

$$5 \times 10 \times 4 = 200$$

$$\begin{array}{r} 650 \\ \hline \end{array} \quad (3)$$

-
17. $v = u + at$

- (a) Work out v when $u = 23$, $a = 4$ and $t = 3$

$$v = 23 + (4)(3)$$

$$\begin{array}{r} 35 \\ \hline \end{array} \quad (2)$$

- (b) Work out u when $v = 30$, $a = 2$ and $t = 8$

$$30 = u + (2)(8)$$

$$\begin{array}{r} 14 \\ \hline \end{array} \quad (2)$$

- (c) Work out t when $v = 40$, $u = 12$ and $a = 4$

$$40 = 12 + (4)t$$

$$\begin{array}{r} 7 \\ \hline \end{array} \quad (2)$$

18. Make m the subject of

$$w(m + n) = x(m - n)$$

$$m = \frac{n(w+x)}{x-w}$$

$$mw + nw = mx - nx$$

$$nw + nx = mx - mw$$

$$nw + nx = m(x - w)$$

$$\frac{nw + nx}{x - w} = m$$

$$\frac{n(w+x)}{x-w} = m$$

.....
(3)

19. On the grid, draw the graph of $3x - 2y = 6$

x	0	1	2	3	4
y	-3	-1.5	0	1.5	3

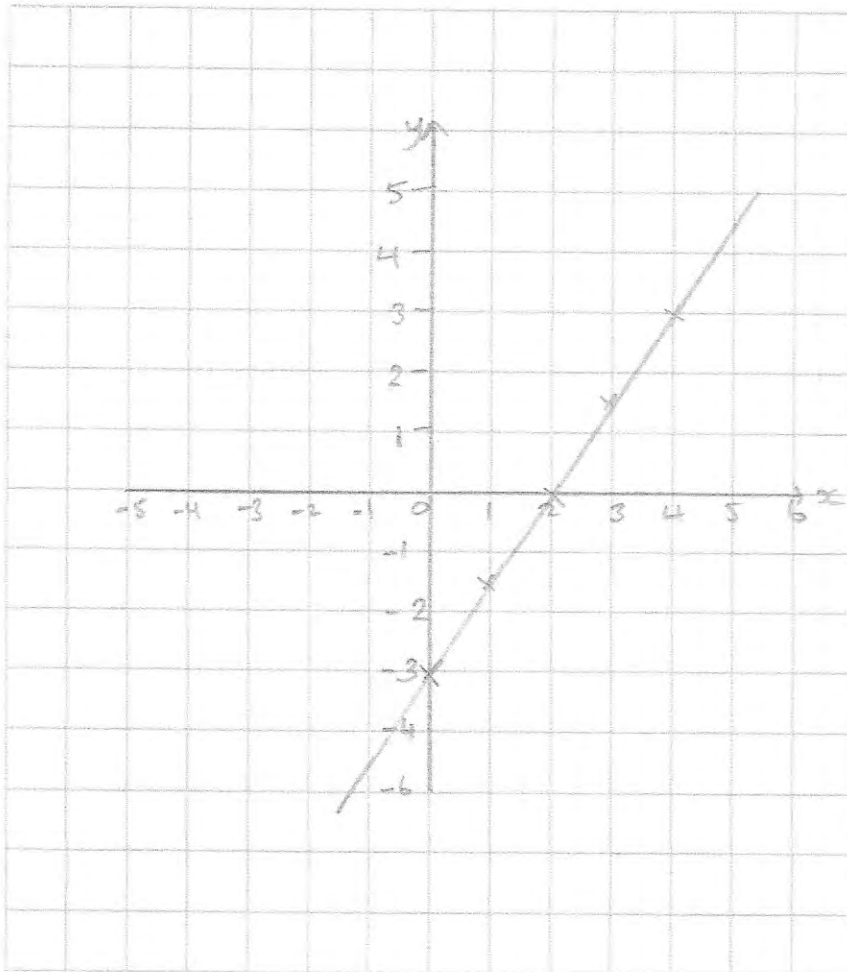

(4)

20. Four chairs and two tables cost £218.
Six chairs and seven tables cost £587.

Find the total cost of buying twenty chairs and five tables.

$$\begin{array}{r}
 4x + 2y = 218 \text{ ①} \times 3 \\
 6x + 7y = 587 \text{ ②} \times 2 \\
 \hline
 12x + 6y = 654 \\
 - 12x + 14y = 1174 \\
 \hline
 -8y = -520 \\
 y = \text{£}65
 \end{array}$$

$$\begin{array}{r}
 4x + 2(65) = 218 \\
 4x = 88 \\
 x = \text{£}22 \\
 20(22) + 5(65) = 765
 \end{array}$$

£ 765
(4)

21. Here is a conversion graph to convert between GB pounds and Polish zloty.

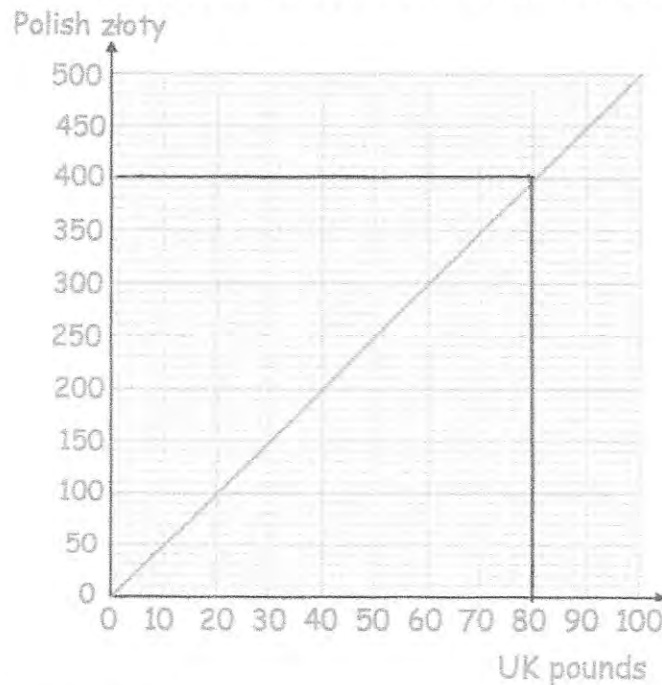

Jack has £400 and 1200 zloty.
His hotel bill is 2000 zloty

He pays the bill with 1200 zloty and some of the pounds.

Work out how much money Jack has left.

$$\begin{array}{r}
 800 \text{ zloty} = \text{£}160 \\
 \text{£}400 - \text{£}160 = 240
 \end{array}$$

£ 240
(4)

22. Nancy goes to the Post Office to exchange money.



Exchange Rates

£1 : \$1.31

£1 : €1.14

*Commission Charged

Nancy changes \$759.80 and €342 into pounds sterling.
The Post Office deducts their commission and gives Nancy £827.20
What is the percentage commission?

$$\$759.80 \div 1.31 = \pounds 580$$

$$\pounds 342 \div 1.14 = \frac{\pounds 300}{\pounds 880}$$

She has changed $880 - 827.20 = \pounds 52.80$

$$\frac{52.8}{880} = 6\%$$

.....6.....%
(4)

23. The ratio of the red cards to black cards in a deck is 3:10
2 more red cards are added to the deck.
The ratio of red cards to black cards is now 1:3

Work out the number of black cards in the deck.

$$\begin{aligned} &+2 \text{ red} && 3x : 10x \\ & && 3x+2 : 10x \\ \text{Since } 1:3 & && 9x+6 = 10x \\ & && x = 6 \end{aligned}$$

$$10 \times 6 = 60$$

.....60.....
(3)

24. The population of a country is increasing by 5% a year.

How many years will it take the population of the country to double?

$$100 \times 1.05^{14} = 197.99\dots$$

$$100 \times 1.05^{15} = 207.89\dots$$

15 years
(3)

25. The length of each side of a regular hexagon is 4.7cm to 1 decimal place.

Write the error interval for the perimeter, P

$$4.65 \times 6 = 27.9$$

$$4.75 \times 6 = 28.5$$

$27.9\text{cm} \leq P < 28.5\text{cm}$
(3)

26. CE and FI are parallel lines.

Angle EDH = 50°

Angle DGF = 100°

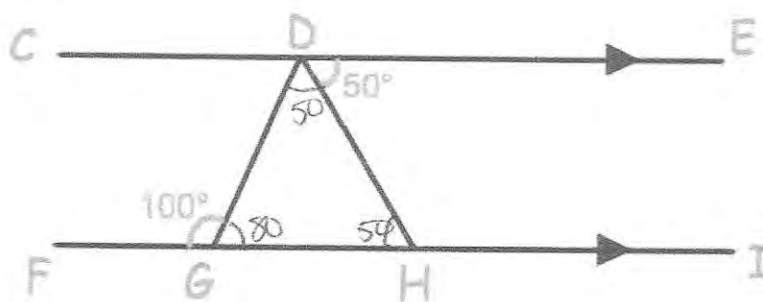

Show, giving reasons, that triangle DGH is isosceles.

$$\angle DGH = 80^\circ \text{ (angles on straight line add to } 180^\circ)$$

$$\angle DHG = 50^\circ \text{ (alternate angles are equal)}$$

$$\angle GDH = 50^\circ \text{ (angles in triangle add to } 180^\circ)$$

Since two angles are equal, DGH is isosceles (4)

27. The diagram shows the position of two towns, A and B.

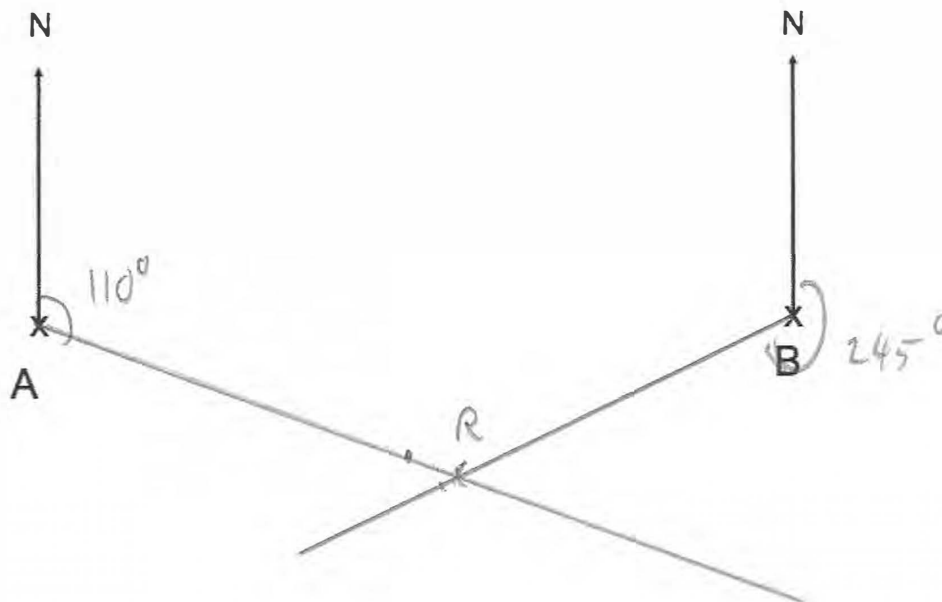

A rugby club, R, has bearing of 110° from town A.
The rugby club, R, has bearing 245° from town B.

In the space above, show the position of the rugby club R.
Mark the position with a cross (x) and label it R.

(3)

28. Shown below is an interior angle from a regular polygon.

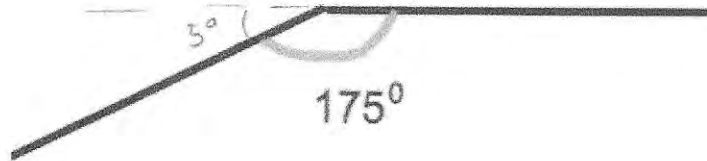

Calculate the number of sides the polygon has.

$$\frac{360}{5} = 72$$

.....72 sides.....
(2)

29. A circular wheel has a diameter of 30cm.
The wheel rolls a distance of 60m.

Calculate the number of complete revolutions completed.

$$\pi \times 30 = 94.2477 \dots \text{cm}$$

$$6000 \div 94.2477 \dots$$

$$= 63.6619 \dots$$

.....63.....
(4)

30. Write the numbers below in the form 2^n

(a) 4

$$\frac{2^2}{\dots\dots\dots} \quad (1)$$

(b) 8

$$\frac{2^3}{\dots\dots\dots} \quad (1)$$

(c) 32

$$\frac{2^5}{\dots\dots\dots} \quad (1)$$

(d) $\frac{1}{2}$

$$\frac{2^{-1}}{\dots\dots\dots} \quad (1)$$

(e) $\frac{1}{4}$

$$\frac{2^{-2}}{\dots\dots\dots} \quad (1)$$

(f) $\sqrt{2}$

$$\frac{2^{1/2}}{\dots\dots\dots} \quad (1)$$

(g) $\sqrt{8}$

$$\begin{aligned} \sqrt{2^3} &= (2^3)^{1/2} \\ &= 2^{3/2} \end{aligned}$$

$$\frac{2^{3/2}}{\dots\dots\dots} \quad (2)$$

31. There are 1500 people at an ice hockey match.
The announcer says that this is exactly 30% more people than the previous match.

Explain why the announcer is wrong.

It would mean there were 1153.846... people at the previous match which is not possible.

$$130\% = 1500$$

$$1\% = 11.538\dots$$

$$100\% = 1153.846\dots$$

(3)

-
32. Expand and simplify $(x - 6)(x + 1)(x - 2)$

$$(x^2 - 6x + x - 6)(x - 2)$$

$$(x^2 - 5x - 6)(x - 2)$$

$$x^3 - 5x^2 - 6x - 2x^2 + 10x + 12$$

$$x^3 - 7x^2 + 4x + 12$$

$$\underline{\underline{x^3 - 7x^2 + 4x + 12}}$$

(3)

33. ABC and BCD are right angle triangles.

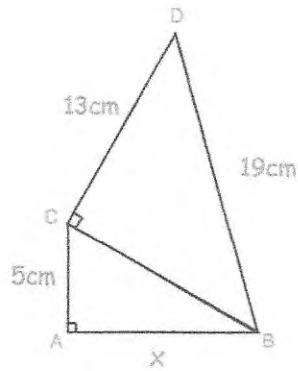

Find the length of AB

$$19^2 - 13^2 = 192$$

$$CB = \sqrt{192}$$

$$= 8\sqrt{3}$$

$$(8\sqrt{3})^2 - 5^2 = 167$$

$$AB = \sqrt{167}$$

$$= 12.9228\dots$$

$$\dots 12.923 \dots \text{cm}$$

(4)

34. Draw the graph of $y = (x - 1)(x - 2)$

$$y = x^2 - x - 2x + 2$$

$$y = x^2 - 3x + 2$$

x	-2	-1	0	1	2	3
y	12	6	2	0	0	2

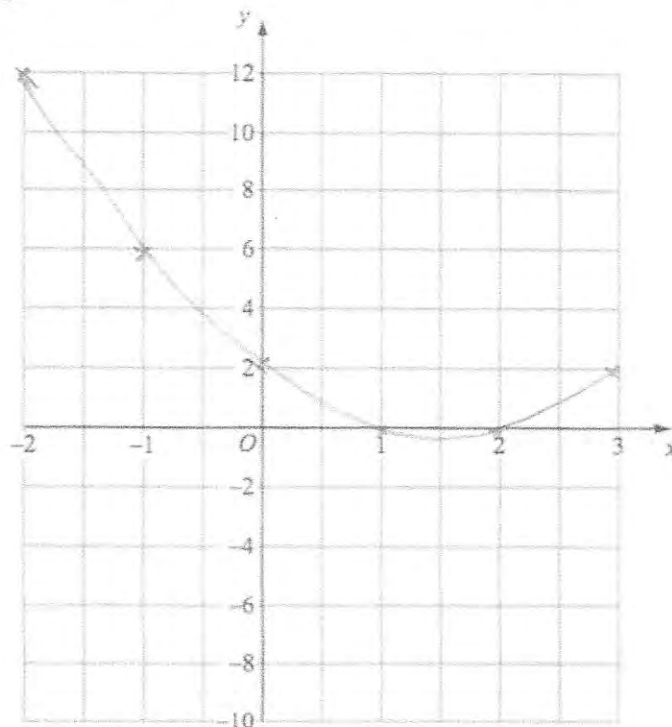

(3)

35. A rectangular lawn is 100m long and 45m wide.
There are 3 circular ponds, with diameters of 20m, 10m and 5m respectively.

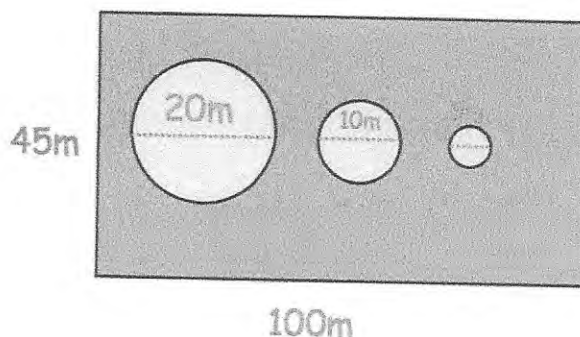

Mrs Jones wants to cover the lawn with grass seed.
Each packet of grass seed covers 50m^2 and costs £1.49

How much will it cost Mrs Jones to cover the lawn with grass seed?

$$45 \times 100 = 4500\text{m}^2$$

$$4500 - 412.33 = 4087.66\text{m}^2$$

$$\pi \times 10^2 = 314.159\dots$$

$$4087.66 \div 50 = 81.7532$$

$$\pi \times 5^2 = 78.539\dots$$

$$82 \times 1.49 = 122.18$$

$$\pi \times 2.5^2 = 19.634\dots$$

$$\underline{412.33\dots}$$

$$\underline{\underline{\pounds 122.18\dots}}$$

(5)

36. The perimeter of this sector is 36cm

Perimeter = 36cm

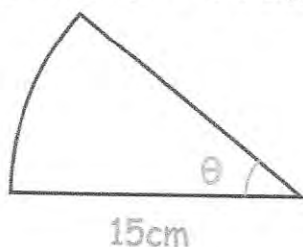

Find the size of the angle, θ

$$\frac{\theta}{360} \times \pi \times 30 = 6$$

$$\frac{\theta}{360} = 0.063$$

$$\underline{\underline{22.9^\circ}}$$

$$\theta = 22.918\dots$$

(3)

37. The areas of these two sectors are equal.

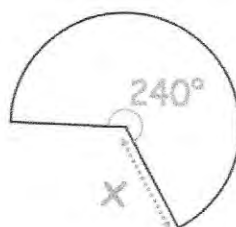
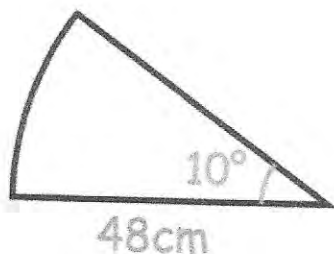

Find the length of x

$$\frac{10}{360} \times \pi \times 48^2 = 64\pi$$

$$\frac{2}{3} x^2 = 64$$

$$x = 4\sqrt{6}$$

$$= 9.7979\dots$$

$$\frac{240}{360} \times \pi \times x^2 = 64\pi$$

$$\frac{240}{360} \times x^2 = 64$$

$$\underline{\underline{9.8}} \dots \text{cm} \quad (4)$$

38. Two right-angled triangles are shown below.

PQ is 10cm.

QR is 3cm.

Angle QRS is 65°

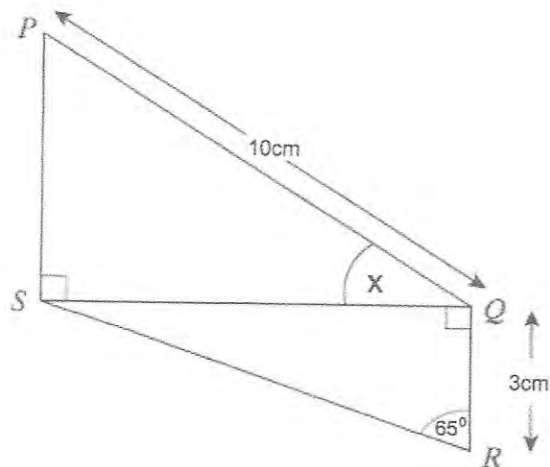

Calculate the size of angle PQS

$$QS = \tan(65) \times 3$$

$$= 6.4335\dots$$

$$\cos x = \frac{6.4335\dots}{10}$$

$$\cos^{-1}\left(\frac{6.4335\dots}{10}\right)$$

$$= 49.96$$

$$\underline{\underline{49.96^\circ}}$$

(5)

39.

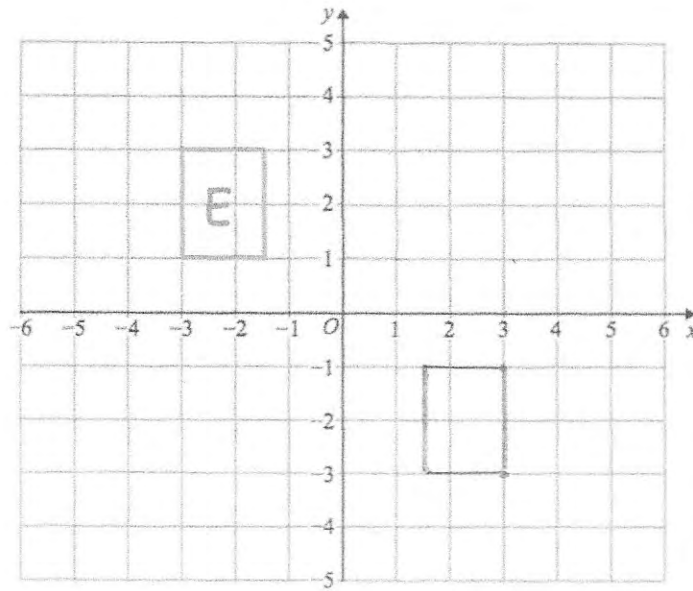

Translate E by $\begin{pmatrix} 4.5 \\ -4 \end{pmatrix}$

(2)

40.

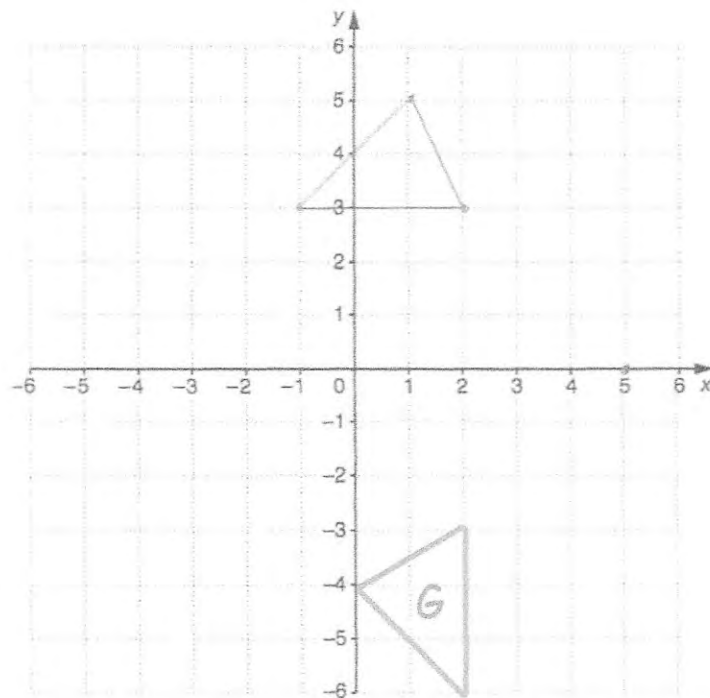

rotate 90° clockwise about $(5, 0)$

(2)

41.

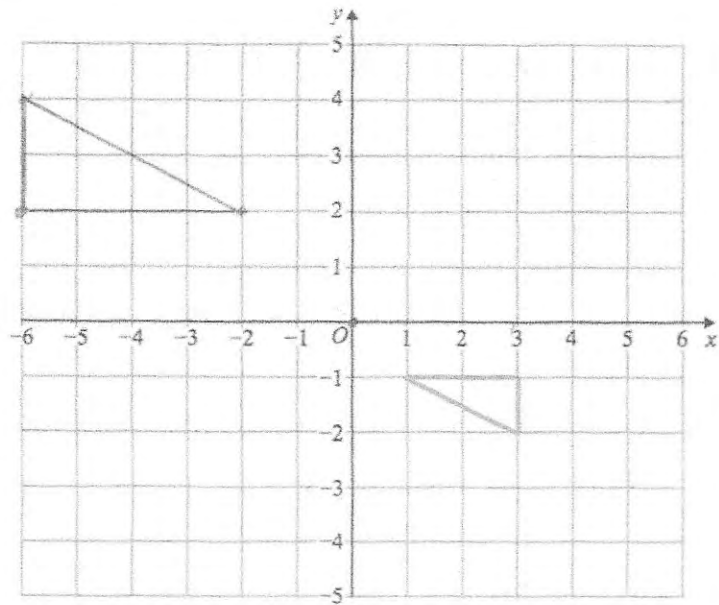

Enlarge by scale factor -2 using $(0, 0)$ as the centre of enlargement

(2)

42.

Reflect shape A in the line $y = x$

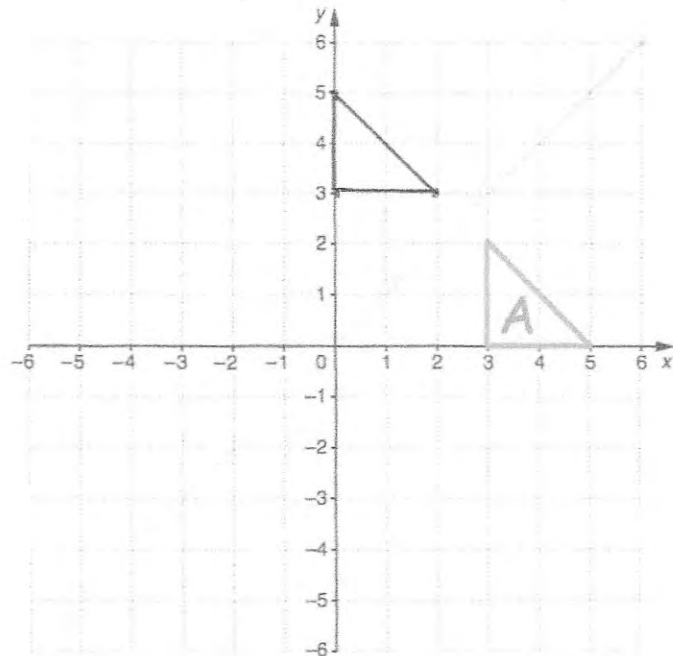

43.

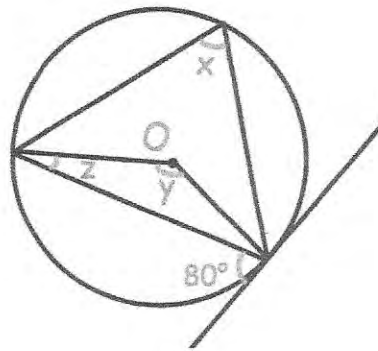

(a) Find the size of angle x.

.....80.....°
(1)

(b) Find the size of angle y.

.....160.....°
(1)

(c) Find the size of angle z.

.....10.....°
(1)

44
mm

11. Teddy leaves home at 13:00
He drives at an average speed of 60km/h for 2½ hours $60 \times 2.5 = 150\text{km}$
Teddy stops for 30 minutes.
He then drives home at an average speed of 50km/h

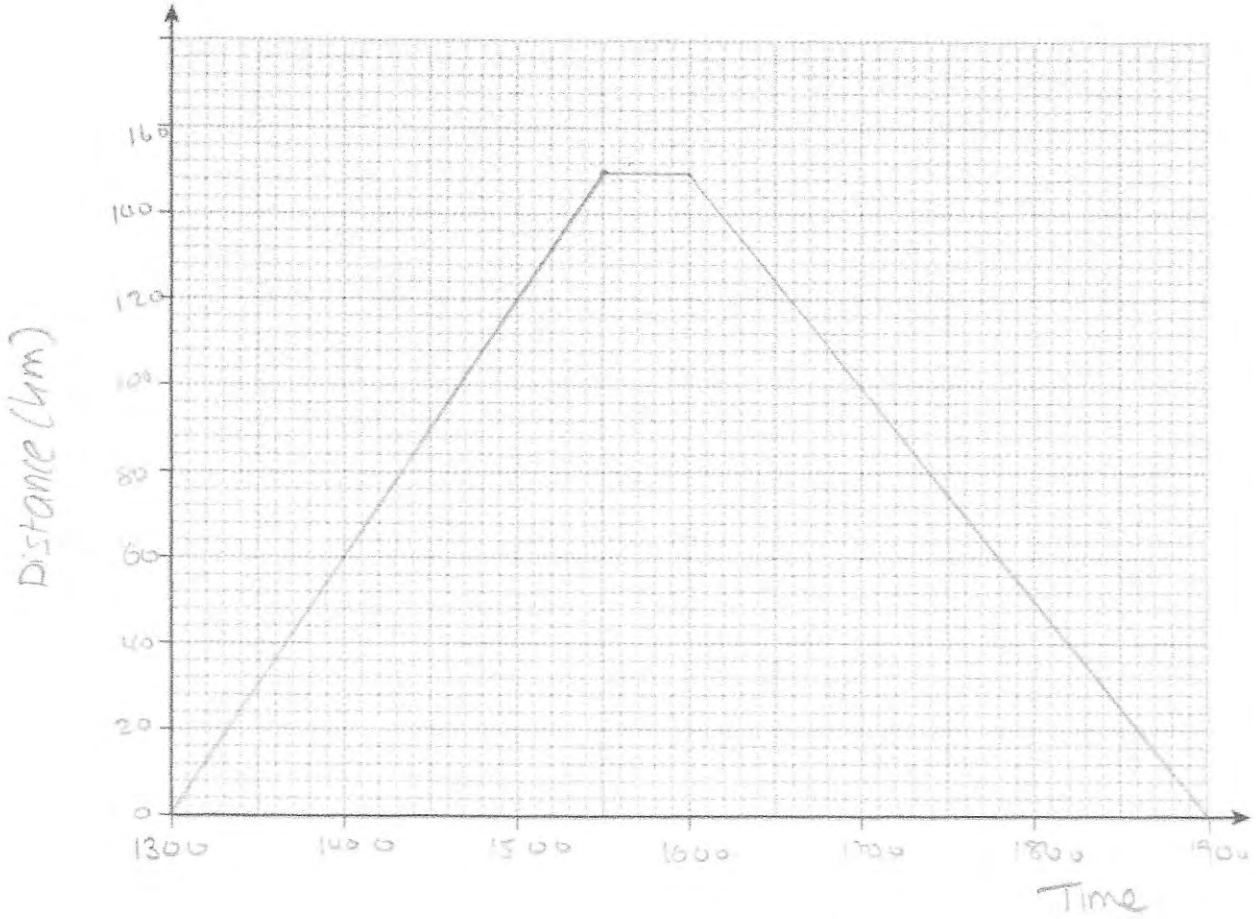

(a) Show this information on a distance-time graph.

(4)

(b) A film starts at 18:45

Does Teddy get home in time for the start?
Explain your answer.

No, he arrives home at 19:00

(1)

45. Michael drives 143 miles from town A to town B in 2 hours 36 minutes.
He then drives from town B to town C at the same speed and it takes 21 minutes.

How far did Michael drive in total?

$$S = \frac{143}{2.6}$$

$$= 55 \text{ mph}$$

$$55 = \frac{D}{0.35}$$

$$= 19.25$$

$$143 + 19.25 = 162.25$$

.....162.25.....miles
(4)

46. Material A has a density of 5.8 g/cm^3 .
Material B has a density of 4.1 g/cm^3 .

377g of Material A and 1.64kg of Material B form Material C.

Work out the density of Material C.

Volume:

$$\text{Material A: } \frac{377}{5.8} = 65 \text{ cm}^3$$

$$\text{Material B: } \frac{1640}{4.1} = 400 \text{ cm}^3$$

$$\underline{\hspace{10em}} \\ 465 \text{ cm}^3$$

$$= \frac{2017}{465} = 4.3376 \text{ g/cm}^3$$

.....4.3376.....g/cm³
(4)

47. The cumulative frequency diagram shows the distribution of speeds for 60 cars on a road.

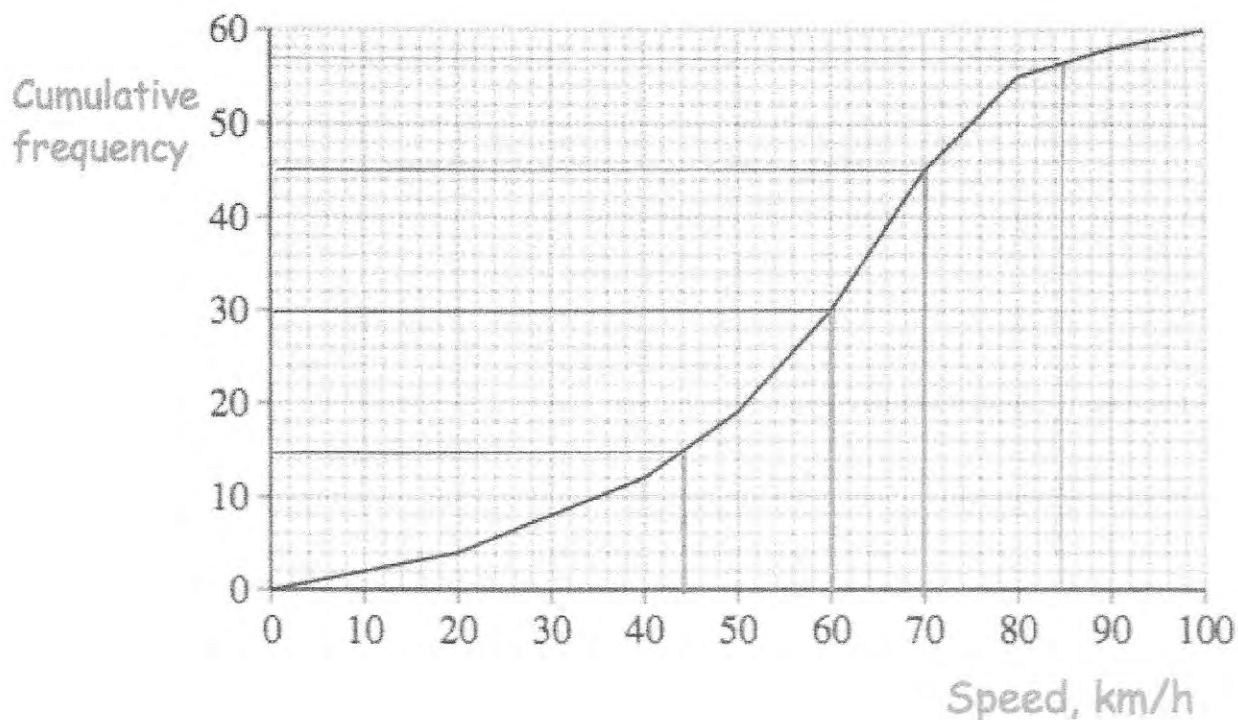

- (a) Estimate the median speed.

60 km/h
(1)

- (b) Estimate the interquartile range of the speeds.

70 - 44

26 km/h
(2)

The speed limit on the road is 85 km/h.

- (c) How many cars exceeded the speed limit?

60 - 57

3
(2)

48. The table shows the heights of the child at a school.

Height	Frequency	x	fx
$120 < h \leq 130$	51	125	6375
$130 < h \leq 140$	120	135	16200
$140 < h \leq 150$	66	145	9570
$150 < h \leq 160$	59	155	9145
$160 < h \leq 170$	4	165	660
	300		<u>41950</u>

Work out an estimate for the mean height.

$$\frac{41950}{300} = 139.8333\dots$$

.....139.8.....cm
(4)

50. A spinner has four sections, each labelled A, B, C and D. Susan and Helen spins the spinner a number of times. The table shows some information.

	Number of spins	Number of B's	Relative frequency of spinning a B
Susan	20	8	0.4
Helen	120	42	0.35

Complete the table.

(2)

51. The Venn diagram shows information about the cars in a car park.

ξ = 150 cars in the car park

R = red cars

J = cars manufactured in Japan

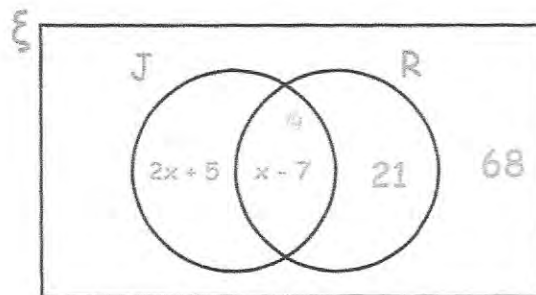

A car is chosen at random.

Work out the probability that it is red.

$$(2x + 5) + (x - 7) + 21 + 68 = 150$$

$$3x + 87 = 150$$

$$3x = 63$$

$$x = 21$$

$$14 + 21 = 35$$

$$\frac{35}{150} = \frac{7}{30}$$

(4)

52. The histogram shows information about how far 150 children swam, when trying to get their swimming certificates.

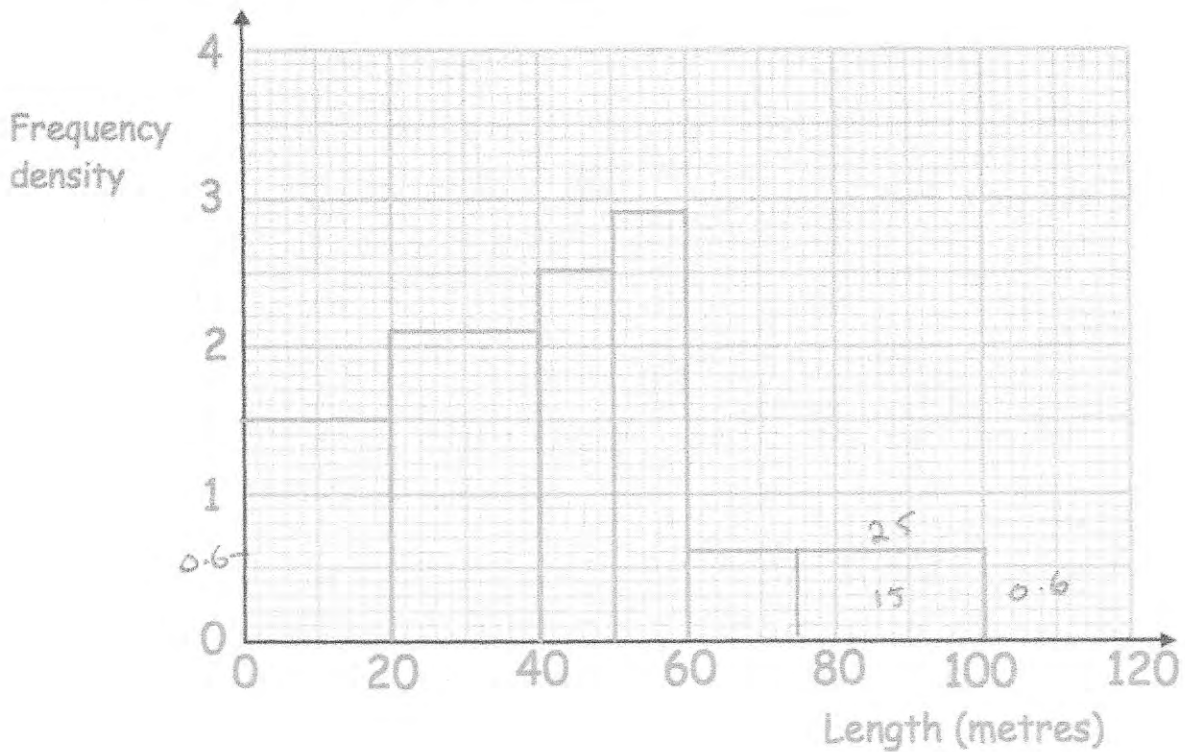

(a) Complete this frequency table.

Length, l metres	Frequency
$0 < l \leq 20$	30
$20 < l \leq 40$	42
$40 < l \leq 50$	25
$50 < l \leq 60$	29
$60 < l \leq 100$	24

$$20 \times 2.1$$

$$10 \times 2.9$$

(2)

- (b) 10% of the swimmers swam further than y metres.
Calculate an estimate of y .

$$0.6 \times \boxed{25} = 15$$

$$10\% \text{ of } 150 = 15$$

75m

(2)

53. Two solid clay models of the Statue of Liberty are mathematically similar.



The smaller model has a height of 15cm.
The larger model has a height of 20cm.

The smaller model has a mass of 108g.

Work out the mass of the larger model.

$$\begin{array}{l}
 15\text{cm} \xrightarrow{\times \frac{4}{3}} 20\text{cm} \\
 108\text{g} \xrightarrow{\times \left(\frac{4}{3}\right)^3} 256\text{g}
 \end{array}$$

$$\begin{array}{r}
 \dots\dots\dots 256 \dots\dots\dots \text{g} \\
 \text{(3)}
 \end{array}$$

- 54.

$$w = aT$$

LB UB

Given $a = 15$ correct to 2 significant figures
and $w = 700$ correct to 2 significant figures
Calculate the upper bound for T

$$T = \frac{w}{a}$$

$$\begin{aligned}
 T_{\max} &= \frac{w_{\max}}{a_{\min}} \\
 &= \frac{705}{14.5}
 \end{aligned}$$

$$48.62$$

$$\begin{array}{r}
 \dots\dots\dots \\
 \text{(3)}
 \end{array}$$

$$T_{\max} = 48.6206896552$$

55. Factorise fully $32y^3 + 24y^2$

$$8y^2(4y+3)$$

$$\frac{8y^2(4y+3)}{(2)}$$

56. (a) Factorise $x^2 - x - 72$

$$\frac{(x+8)(x-9)}{(2)}$$

(b) Factorise $4x^2 + 12x - 7$

$$\frac{(2x-1)(2x+7)}{(2)}$$

57. Solve $\frac{x+3}{4} = \frac{3}{x-1}$

$$(x+3)(x-1) = 12$$

$$x^2 + 3x - x - 3 = 12$$

$$x^2 + 2x - 15 = 0$$

$$\frac{(x+5)(x-3)}{(3)}$$

Answer

$$\boxed{\begin{array}{l} x = -5 \\ \text{or } x = 3 \end{array}}$$

58. Solve $x^2 - 6x - 20 = 0$

Give your answers to 1 decimal place.

$$x = \frac{-b \pm \sqrt{b^2 - 4ac}}{2a}$$

$$= \frac{-(-6) \pm \sqrt{(-6)^2 - 4(1)(-20)}}{2(1)}$$

$$= 3 \pm \sqrt{29}$$

$$= 8.38 \text{ or } -2.38$$

$$\underline{\underline{8.4 \text{ or } -2.4}} \quad (3)$$

59. Here are the n th terms of 4 sequences.

Sequence 1	nth term	$3n + 1$	4	7	10
Sequence 2	nth term	$5n + 10$	15	20	25
Sequence 3	nth term	$10n$	10	20	30
Sequence 4	nth term	$5n - 1$	4	9	14

For each sequence state whether the numbers in the sequence are

- A Always multiples of 5
- S Sometimes multiples of 5
- N Never multiples of 5

Sequence 1 ... S

Sequence 2 ... A

Sequence 3 ... A

Sequence 4 ... N

(4)

60. Here are the first 5 terms of a quadratic sequence

4 10 18 28 40

Find an expression, in terms of n , for the n th term of this quadratic sequence.

$a+b+c$	4	10	18	28	40	$a=1$
$3a+b$		6	8	10	12	$b=3$
$2a$			2	2	2	$c=0$

$n^2 + 3n$
(3)

61. Shown is a pentagon, with the size of each angle shown.

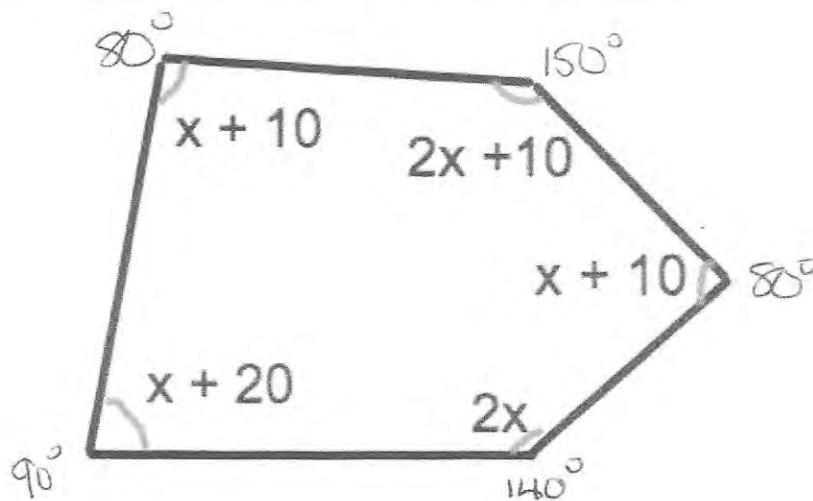

Find the size of the largest angle.

$$7x + 50 = 540$$

$$x = 70^\circ$$

.....150.....
(4)

62. (a) Solve the inequality $4x + 6 \geq 2$

$$4x \geq -4$$

$$x \geq -1$$

$$\underline{x \geq -1} \dots \dots \dots$$

(2)

(b) Write down the inequality shown by the diagram.



$$\underline{x < 3} \dots \dots \dots$$

(1)

(c) Write down all the integers that satisfy both inequalities shown in part (a) and (b).

$$\underline{-1, 0, 1, 2} \dots \dots \dots$$

(1)

63.

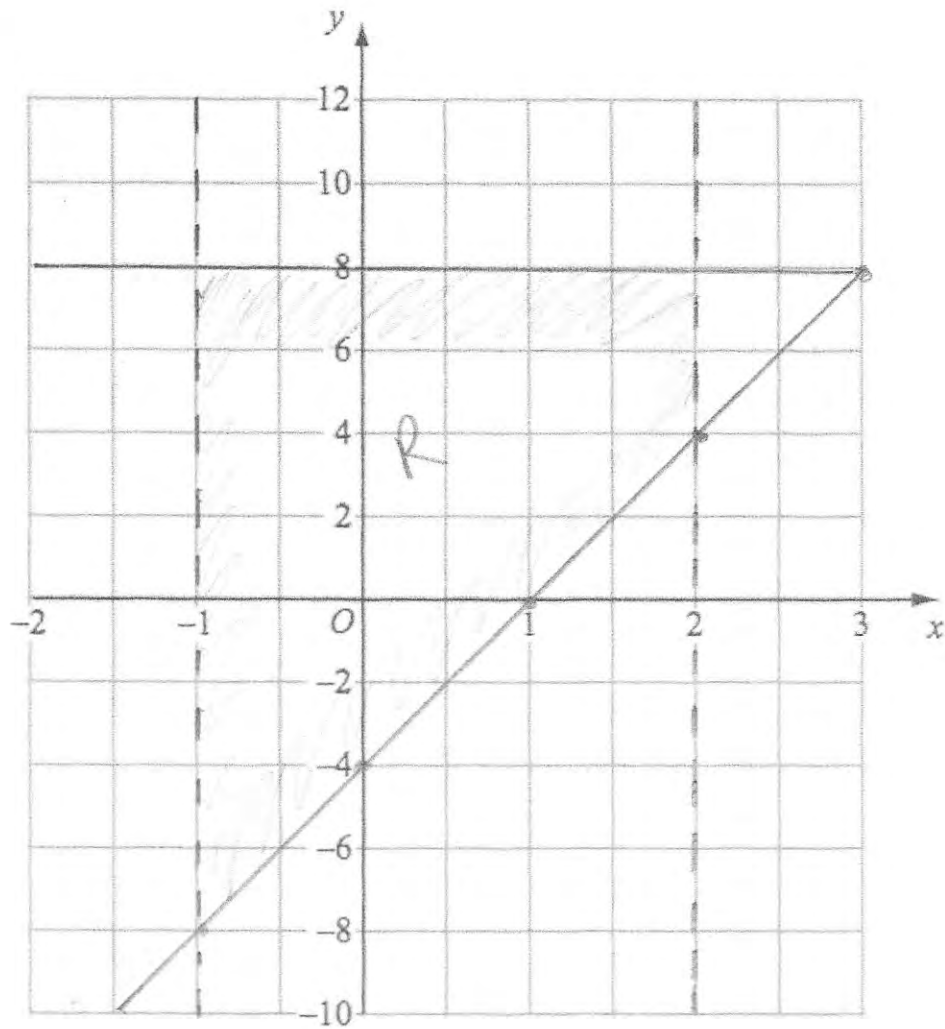

On the grid, label the region that satisfies all three of these inequalities

$$-1 < x < 2$$

$$y \leq 8$$

$$y \geq 4x - 4$$

(4)

64. Solve the inequality $x^2 - 6x + 8 \geq 0$

$$(x - 2)(x - 4) \geq 0$$

$$x \geq 2$$

or

$$x \leq 4$$

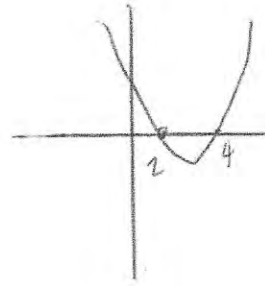

(3)

65. The circle below has centre (0, 0).
The point (-15, 8) is a point on the circle.

Find the equation of the circle.

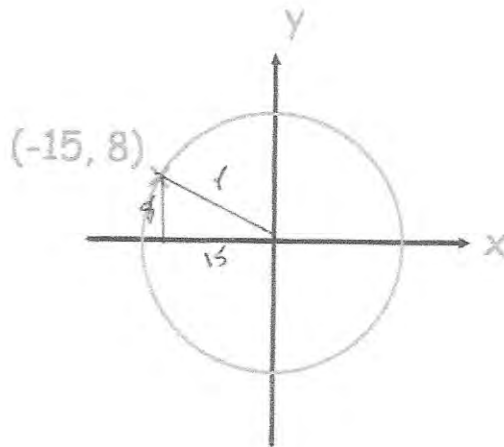

$$15^2 + 8^2 = r^2$$

$$225 + 64 = r^2$$

$$289 = r^2$$

$$r = 17$$

$$x^2 + y^2 = 289$$

(3)

66.

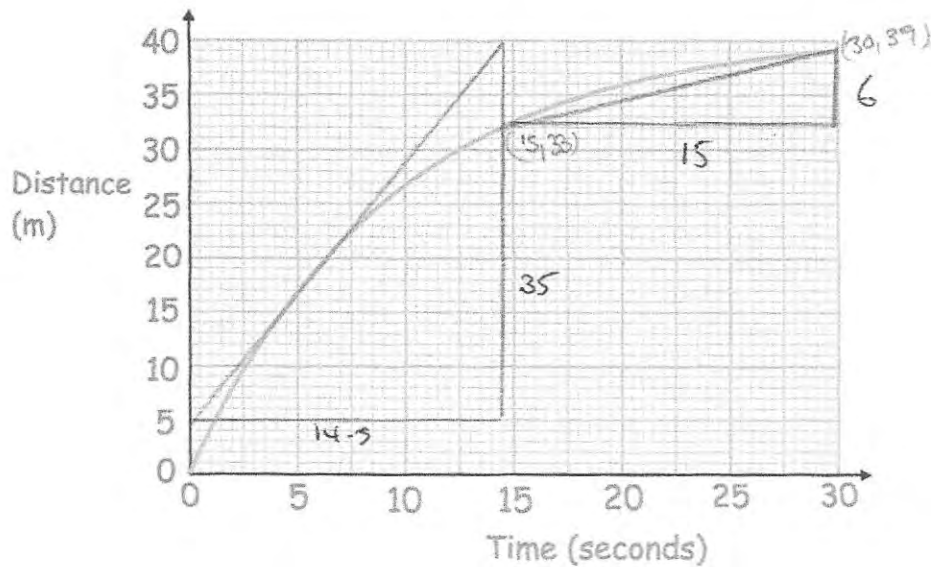

(a) Work out the speed at $t = 5$ seconds

$$\frac{\text{Rise}}{\text{Run}} = \frac{35}{14.5} = 2.413 \dots$$

$$= 2.41$$

.....2.41.....m/s
(3)

(b) Work out the average speed between 15 and 30 seconds

$$\frac{\text{Rise}}{\text{Run}} = \frac{6}{15} = 0.4$$

.....0.4.....m/s
(3)

67. Solve

$$\frac{3}{x-2} + \frac{3}{x+2} = 2$$

$$\frac{3(x+2) + 3(x-2)}{(x-2)(x+2)} = 2$$

$$\frac{3x+6+3x-6}{(x-2)(x+2)} = 2$$

$$6x = 2(x-2)(x+2)$$

$$6x = 2(x^2-4)$$

$$6x = 2x^2-8$$

$$0 = 2x^2-6x-8$$

$$\div 2 \quad 0 = x^2-3x-4$$

$$(x+1)(x-4)$$

$x = -1$ or $x = 4$
.....
(5)

68. The functions $f(x)$, $g(x)$ and $h(x)$ are given by the following:

$$f(x) = x^2 - 3$$

$$g(x) = 2x + 1$$

$$h(x) = \frac{x}{2}$$

(a) Find $fg(x)$

$$(2x+1)^2 - 3$$

$$(2x+1)(2x+1) - 3$$

$$4x^2 + 4x - 2$$

$$\frac{4x^2 + 4x - 2}{(2)}$$

(b) Find $gh(x)$

$$2\left(\frac{x}{2}\right) + 1$$

$$\frac{x+1}{(2)}$$

(c) Find $h^{-1}(x)$

$$y = \frac{x}{2}$$

$$2y = x$$

$$x = 2y$$

$$\frac{h^{-1}(x) = 2x}{(2)}$$

69. Sketch the graph of $y = \sin(x)$ for $0^\circ \leq x \leq 360^\circ$

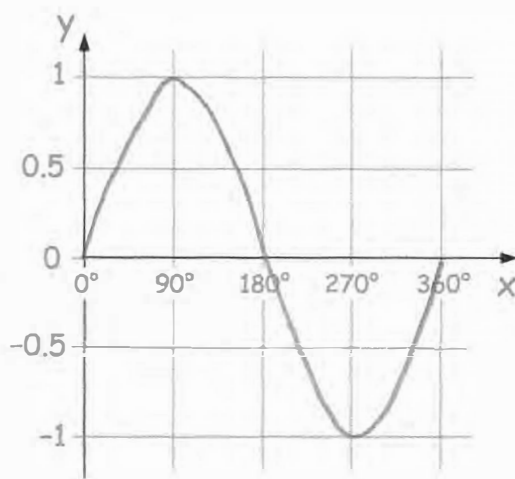

(2)

70.

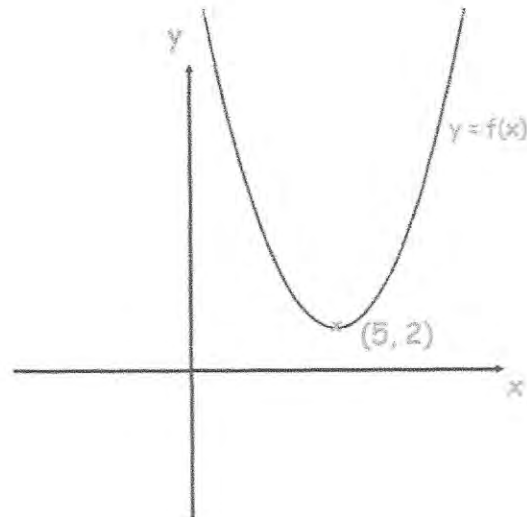

Shown is the curve with equation $y = f(x)$

The coordinates of the minimum point of the curve are $(5, 2)$.

Write down the coordinates of the minimum point of the curve with equation

(a) $y = f(x) - 4$

(.....5.....,-2.....)
(1)

(b) $y = f(x - 2)$

(.....7.....,2.....)
(1)

(c) $y = f(-x)$

(.....-5.....,2.....)
(1)

71. Write $x^2 + 12x - 1$ in the form $(x + a)^2 + b$, where a and b are constants.

$$(x + 6)^2 - 36 - 1$$

$$(x + 6)^2 - 37$$

$$\frac{(x + 6)^2 - 37}{(3)}$$

72. (a) Show that the equation $3x - x^3 = -11$ has a solution between $x = 2$ and $x = 3$

$$3x - x^3 + 11 = 0$$

when $x = 2$ $3(2) - 2^3 + 11 = 9$

$x = 3$ $3(3) - 3^3 + 11 = -7$

Since there is a change of sign between $x = 2$ and $x = 3$ (2)

- (b) Show that the equation $3x - x^3 = -11$ can be rearranged to give

$$x = \sqrt[3]{3x + 11} \quad 3x + 11 = x^3$$

$$\sqrt[3]{3x + 11} = x$$

(2)

- (c) Starting with $x_0 = 3$, use the iteration formula $x_{n+1} = \sqrt[3]{3x_n + 11}$ three times to find an estimate for the solution of $3x - x^3 = -11$

$$x_1 = \sqrt[3]{(3 \times 3) + 11} = 2.714417617$$

$$x_2 = \sqrt[3]{(3 \times 2.714\dots) + 11} = 2.675091113$$

$$x_3 = \sqrt[3]{(3 \times 2.675\dots) + 11} = 2.669584272$$

(3)

73. Complete the table of values for $y = \frac{5}{x}$

x	0.5	1	2	4	8	10
y	10	5	2.5	1.25	0.625	0.5

(2)

(b) On the grid, draw the graph of $y = \frac{5}{x}$ for $0.5 \leq x \leq 10$

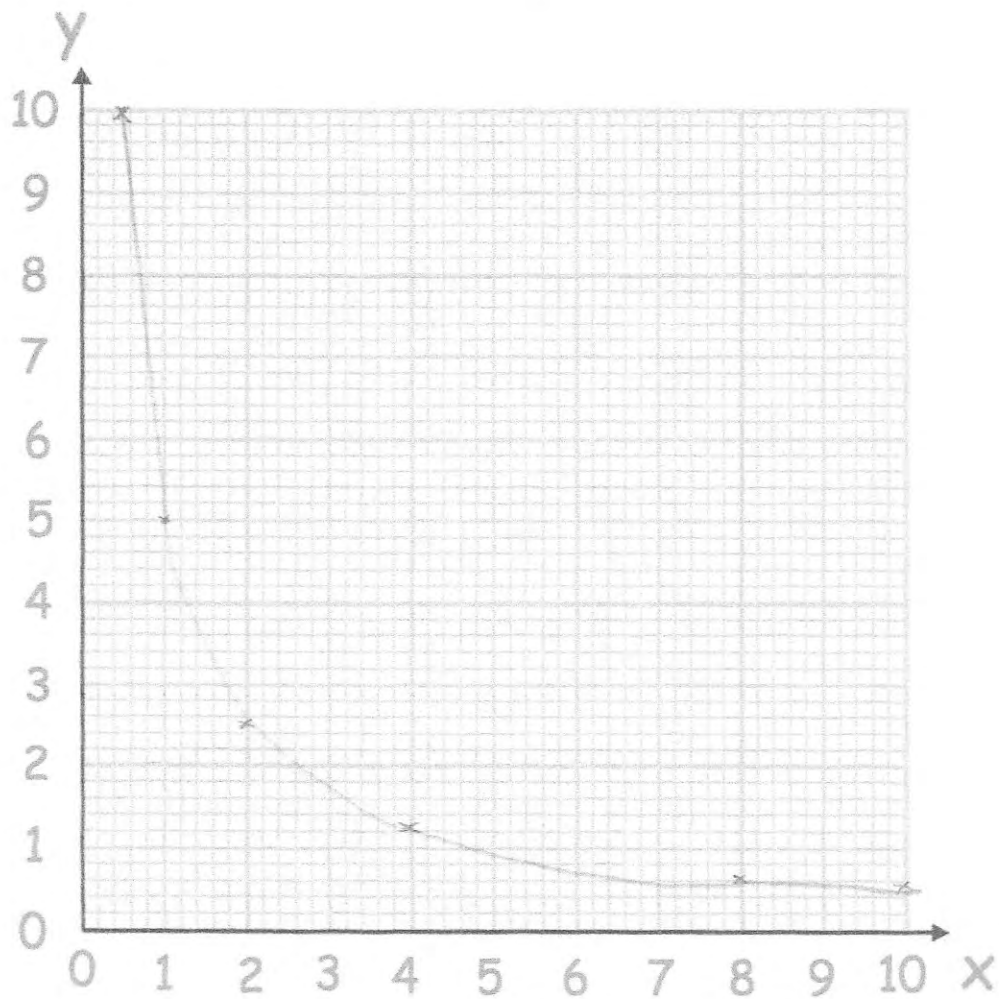

(2)

74.

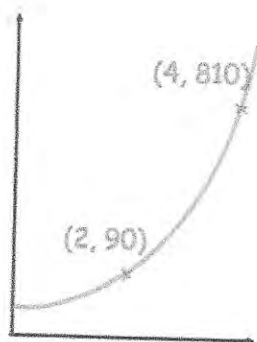

The sketch shows a curve with equation $y = ab^x$ where a and b are constants and $b > 0$

The curve passes through the points $(2, 90)$ and $(4, 810)$

Calculate the value of a and b

$(2, 90)$

$90 = ab^2$ (1)

$(4, 810)$

$810 = ab^4$ (2)

(2) \div (1)

$9 = b^2$

$b = 3$

Sub into (1)

$90 = a \times 9$

$a = \dots 10 \dots$

$b = \dots 3 \dots$

(3)

75. Use algebra to prove

$0.\dot{2}\dot{8} = \frac{13}{45}$

$\frac{26}{90} \xrightarrow{\div 2} \frac{13}{45}$

$x = 0.28888\dots$

$10x = 2.8888\dots$

$100x = 28.888\dots$

$90x = 26$

76. A shed has dimensions, in metres, of

$$\text{height} = \sqrt{5}, \text{ width} = \sqrt{6} \text{ and length} = \frac{9}{\sqrt{2}}$$

Find the volume of the shed.

Give your answer in the form $a\sqrt{15}$, where a is an integer.

$$\sqrt{5} \times \sqrt{6} \times \frac{9}{\sqrt{2}}$$

$$\sqrt{30} \times \frac{9}{\sqrt{2}} = \frac{9\sqrt{30}}{\sqrt{2}} = 9\sqrt{15}$$

$$\dots\dots\dots 9\sqrt{15} \dots\dots\dots \text{m}^3$$

(3)

77. Here is a circle, centre O, and the tangent to the circle at the point (2, -4).

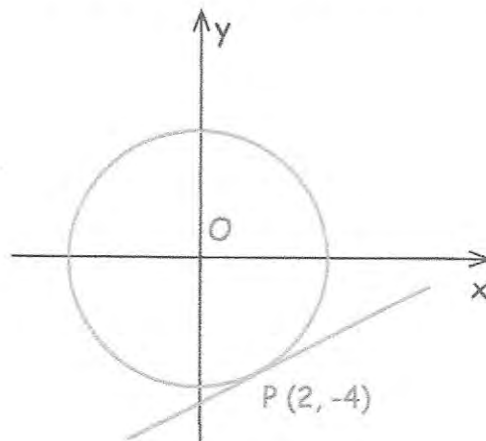

Find the equation of the tangent at the point P.

$$\text{Gradient } OP = -2$$

$$y = \frac{1}{2}x + c$$

$$-4 = \frac{1}{2}(2) + c$$

$$c = -5$$

$$\dots\dots\dots y = \frac{1}{2}x - 5 \dots\dots\dots$$

(3)

78.

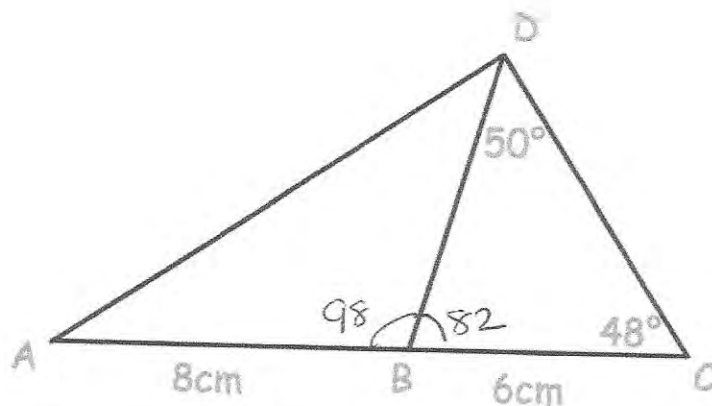

ACD is a triangle and B is a point on AC.
 AB = 8cm and BC is 6cm.
 Angle BCD = 48° and angle BDC = 50°.

(a) Find the length of BD.

$$\frac{x}{\sin 48} = \frac{6}{\sin 50}$$

..... 5.82cm
 (3)

(b) Find the length of AD.

$$AD^2 = 8^2 + 5.82^2 - 2(8)(5.82)\cos 98$$

$$AD^2 = 110.83 \dots$$

..... 10.53cm
 (3)

(c) Find the area of triangle ABD.

$$\frac{1}{2}(8)(5.82)\sin 98$$

$$= 23.05$$

..... 23.05cm²
 (3)

79. A cylinder is placed on a table.
The cylinder has a weight of 400N and has a diameter of 10cm.

Work out the pressure on the table in newtons/cm²

$$\begin{aligned} \text{Area} &= \pi(5^2) \\ &= 78.5398\dots \end{aligned}$$

$$P = \frac{F}{A} = \frac{400}{78.54} = 5.092958179$$

.....5.093.....N/cm²
(3)

80.

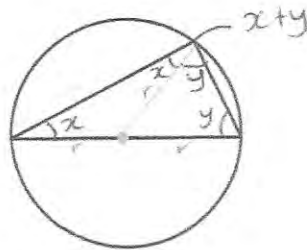

Prove that the angle in a semi-circle is always 90°

$$x + y + (x + y) = 180^\circ$$

$$2x + 2y = 180^\circ$$

$$x + y = 90^\circ$$

(3)

81. The mass of a paperweight is m grams.
The length of the paperweight is L centimetres.
 m is directly proportional to the cube of L .

$$m = 4968 \text{ when } L = 12$$

- (a) Work out an equation connecting m and L

$$m \propto L^3 \quad 4968 = k(12)^3$$

$$m = kL^3 \quad k = 23/8$$

$$m = \frac{23}{8} L^3 \dots\dots\dots (3)$$

- (b) Work out the mass of a paperweight with a length of 4 centimetres

$$m = \frac{23}{8} (4)^3$$

$$\dots\dots\dots 184g \dots\dots\dots (2)$$

82. A straight line passes through the points $A(1, 4)$ and $B(5, 16)$.

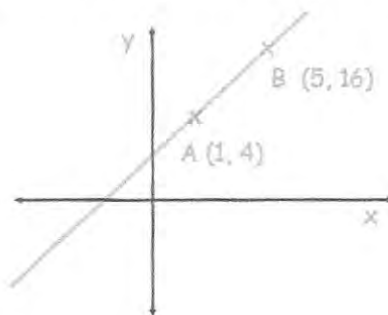

- (a) Find the equation of the line parallel to AB that passes through $(1, 7)$

$$\frac{12}{4} = 3 \quad y = 3x + C$$

$$4 = 3(1) + C \quad 7 = 3(1) + C$$

$$C = 1 \quad 4 = C$$

$$\dots\dots\dots y = 3x + 4 \dots\dots\dots (2)$$

- (b) Find the equation of the line perpendicular to AB that passes through the midpoint of AB

$$\text{Midpoint} = \frac{1+5}{2}, \frac{4+16}{2} \quad \text{perpendicular gradient} = -1/3$$

$$= (3, 10) \quad 10 = -\frac{1}{3}(3) + C$$

$$\dots\dots\dots y = -\frac{1}{3}x + 11 \dots\dots\dots (3)$$

$$10 = -1 + C$$

$$C = 11$$

83.

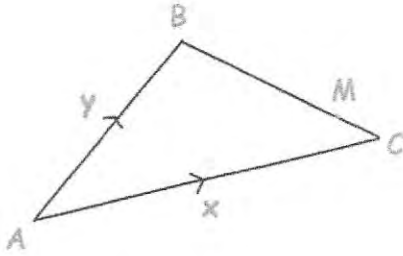

ABC is a triangle.

M lies on BC such that $BM = \frac{4}{5} BC$

Express these vectors in terms of x and y

(a) \overrightarrow{BC}

$$-y + x \quad (1)$$

(b) \overrightarrow{BM}

$$-\frac{4}{5}y + \frac{4}{5}x \quad (1)$$

(c) \overrightarrow{AM}

$$y - \frac{4}{5}y + \frac{4}{5}x$$

~~$$y - \frac{4}{5}y + \frac{4}{5}x \quad (1)$$~~

$$\frac{1}{5}y + \frac{4}{5}x$$

84. Shown below is a rectangular based pyramid.
The apex E is directly over the centre of the base.

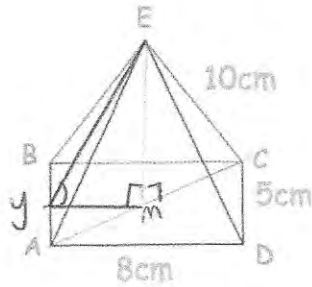

AD = 8cm
CD = 5cm
CE = 10cm

- (a) Calculate the height of the pyramid

$$AC^2 = 8^2 + 5^2$$

$$AC^2 = 89$$

$$AC = \sqrt{89}$$

$$MC = \frac{\sqrt{89}}{2}$$

$$= 4.71699\dots$$

$$10^2 = MC^2 + EM^2$$

$$EM^2 = 77.75$$

$$EM = 8.8175\dots$$

$$= 8.82$$

..... 8.82 cm
(4)

- (b) Calculate angle between the face ABE and the base ABCD

$$\tan \alpha = \frac{O}{A}$$

$$\tan \alpha = \frac{8.8175\dots}{4}$$

$$\tan^{-1}\left(\frac{8.8175}{4}\right) = 65.6^\circ$$

..... 65.6
(3)

85. This sphere and cone have the same volume.

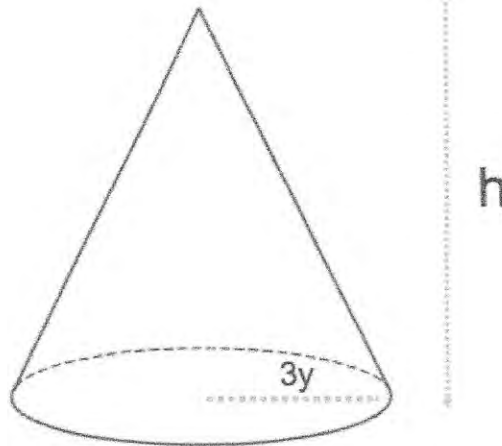

Find an expression for h in terms of y .

$$V = \frac{4}{3} \pi r^3$$

$$V = \frac{4}{3} \pi \times (3y)^3$$

$$V = \frac{4}{3} \pi \times 27y^3$$

$$\frac{4}{3} \pi \times 27y^3 = \frac{1}{3} \pi \times 9y^2 \times h$$

$$4\pi \times 27y^3 = \pi \times 9y^2 \times h$$

$$108y^3 = 9y^2 h$$

$$12y = h$$

$$V = \frac{1}{3} (\pi r^2) h$$

$$V = \frac{1}{3} \pi (3y)^2 \times h$$

$$V = \frac{1}{3} \pi \times 9y^2 \times h$$

$$h = 12y \dots \dots \dots (5)$$

86. There are 50 students in tutor groups A and B. Each student studies one language.

	French	German
Tutor Group A	13	15
Tutor Group B	5	17
	18	32

Two of these students are selected at random.

Calculate the probability that the two chosen students study the same language.

$$P(FF) = \frac{18}{50} \times \frac{17}{49} = \frac{153}{1225}$$

$$P(GG) = \frac{32}{50} \times \frac{31}{49} = \frac{496}{1225}$$

$$\frac{649}{1225}$$

(4)

87. In the diagram, the lines CE and DF intersect at G. CD and FE are parallel and CD = FE.

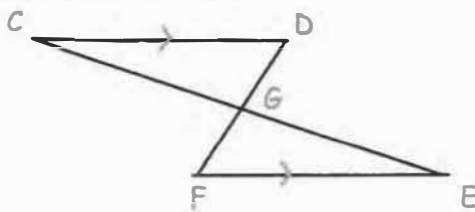

Prove that triangles CDG and EFG are congruent.

$$\begin{aligned}
 & CD = FE \quad (\text{given}) \\
 & \angle DCE = \angle FEC \quad (\text{alternate angles are equal}) \\
 & \angle CDF = \angle FED \quad (\text{alternate angles are equal}) \\
 & \triangle CDG \text{ \& } \triangle EFG \text{ are congruent (ASA)}
 \end{aligned}$$

(3)

88. The first five terms of a linear sequence are 5, 11, 17, 23, 29 ...

(a) Find the n th term of the sequence

$$6(1) = 6 - 1 = 5 \quad 6n - 1$$

$$6(2) = 12 - 1 = 11$$

$$\dots 6n - 1 \dots \dots \dots$$

(2)

A new sequence is generated by squaring each term of the linear sequence and then adding 5.

(b) Prove that all terms in the new sequence are divisible by 6.

$$(6n - 1)^2 + 5$$

$$36n^2 - 12n + 1 + 5$$

$$36n^2 - 12n + 6$$

$$6(6n^2 - 2n + 1) \therefore \text{divisible by } 6$$

(4)

89. Below is a right angled triangle.

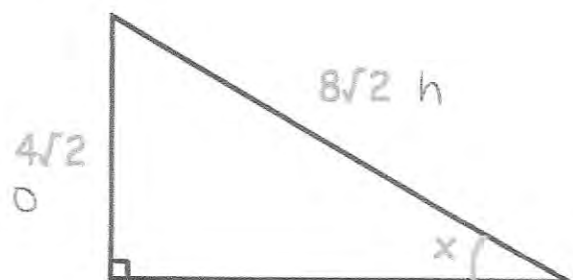

Show that angle $x = 30^\circ$

Include all your working.

$$\sin x = \frac{4\sqrt{2}}{8\sqrt{2}} = \frac{1}{2}$$

$$x = \sin^{-1}\left(\frac{1}{2}\right)$$

$$= 30^\circ$$

(2)

90. On 1st March 2001, the ratio of Freddie's age to his mother's age was 1:11
On 1st March 2018, the ratio of Freddie's age to his mother's age was 2:5

Write the ratio of Freddie's age to his mother's age on 1st March 2030

$$2001: x : 11x$$

$$2018: x + 17 : 11x + 17 = 2:5$$

$$\frac{x + 17}{11x + 17} = \frac{2}{5}$$

$$5x + 85 = 22x + 34$$

$$51 = 17x$$

$$x = 3$$

So in 2001,
Freddie is 3 and
his mother is 33.

In 2030: Freddie is 32
Mother is 62
32:62 $\div 2$.

$$\dots 16:31 \dots$$

(4)

91.

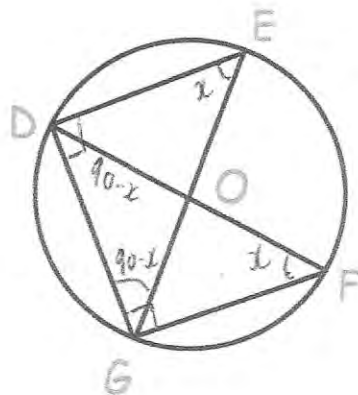

O is the centre of the circle.

DOF and EOG are diameters of the circle shown.

Prove triangles DEG and DFG are congruent.

$\angle DEG = \angle DFG = x^\circ$ As angles in the same segment are equal

$\angle DGF = \angle EDG = 90^\circ$ As angle in a semi-circle is 90°

$\angle FDG = \angle EGD = 90^\circ - x$ As angles in a triangle add up to 180°

$DF = EG$ As both lines are diameters

$\therefore \triangle DEG$ and $\triangle DFG$ are congruent (3)
due to ASA.

92. Here is a speed-time graph for a remote-controlled car

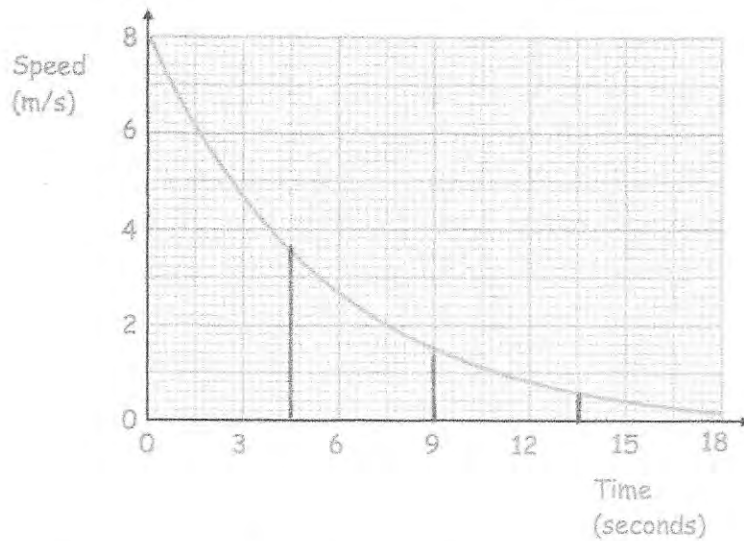

- (a) Work out an estimate for the distance travelled over the first 12 seconds of the journey.
Use 4 strips of equal width.

$$\frac{1}{2}(a+b) \times h$$

$$\textcircled{1} \frac{1}{2}(8 + 3.5) \times 4.5 = 25.875$$

$$\textcircled{4} \frac{1}{2}(0.6 + 0.2) \times 4.5 = 1.8$$

$$\textcircled{2} \frac{1}{2}(3.5 + 1.5) \times 4.5 = 11.25$$

$$\textcircled{3} \frac{1}{2}(1.5 + 0.6) \times 4.5 = 4.725$$

$$\underline{43.65} \text{ m} \quad (4)$$

- (b) Is your answer to (a) an overestimate or an underestimate of the actual distance travelled?
Explain your answer

Overestimate as each trapezium is over the actual curve so the area will be slightly less than what has been used. (1)

93. Shown is triangle ABC

ABC is rotated 180° about $(-1, 2)$ and then translated by the vector $\begin{pmatrix} 2 \\ -4 \end{pmatrix}$

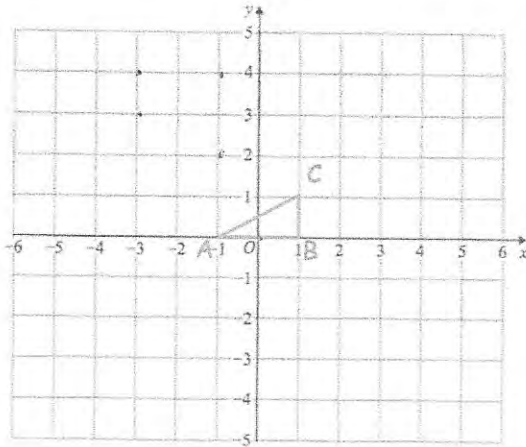

Write down the coordinate of the invariant point.

(0, 0).....
(3)

94. Solve the equations

$$y = x^2 - 5$$

$$y = 2x - 2$$

$$x^2 - 5 = 2x - 2$$

$$x^2 - 2x - 5 + 2 = 0$$

$$x^2 - 2x - 3 = 0$$

$$(x - 3)(x + 1) = 0$$

$$x = 3 \quad x = -1$$

$$y = 4 \quad y = -4$$

$$x = 3 \text{ or } x = -1$$

$$y = 4 \quad y = -4 \quad (5)$$

$$(3, 4) \text{ and } (-1, -4)$$