

Paper 3 Preparation Paper

OCR Foundation



Corbettmaths

This is a collection of questions broadly covers the specification.

The topics highlighted in green (and bold) are the starred topics from the Paper 3 Revision Checklist

Guidance

1. Check your answers seem right.
2. Always show your workings
3. Take your time when working through this collection of questions

Revision for this test



1. Here are four digits.

4 8 3 5

Use all four digits to make the number closest to 4000.

3854
(1)

2. Arrange these distances in order, from shortest to longest

6.077m 6.31m 6.19m 6.4m 6.009m

6.009m 6.077m 6.19m 6.31m 6.4m

(1)

3. Sian thinks of two different numbers

The two numbers have a total of 3

The same numbers have a difference of 5

What two numbers did Sian think of?

$$-1 + 4 = 3$$

-1 4

(2)

4. Write all the numbers between 12 and 50 that are factors of 90

15, 18, 30, 45

(2)

5. Here is a function machine.



The output is equal to the input.

Find the input.

$$\begin{aligned}6x - 80 &= x \\5x &= 80 \\x &= 16\end{aligned}$$

16.....
(2)

6.

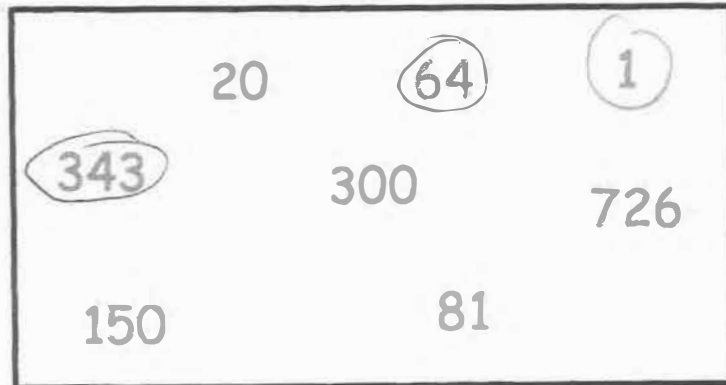

Circle all the cube numbers.

(2)

7. A bus heading to Belfast leaves Antrim every 25 minutes.
A bus heading to Ballymena leaves Antrim every 30 minutes

At 10am bus to Belfast and a bus to Ballymena both leave Antrim Bus Station.

Work out the next time that both buses leave at the same time.

25, 50, 75, 100, 125, 150 150 minutes = 2.5 hours
30, 60, 90, 120, 150

12:30pm
(3)

8. Complete the table

Fraction	Decimal	Percentage
$\frac{11}{100}$	0.11	11%
$\frac{9}{20}$	0.45	45%
$\frac{17}{25}$	0.68	68%
$\frac{3}{8}$	0.375	37.5%

(3)

9. Heather is making chocolate biscuits.
She has:

2kg of flour
1kg of butter
340g of icing sugar
200g of chocolate

Here is the list of ingredients for making 20 biscuits.

makes 20	
100g flour	$2000 \div 100 = 20$
120g butter	$1000 \div 120 = 8\frac{2}{3}$
80g icing sugar	$340 \div 80 = 4.25$
25g chocolate	$200 \div 25 = 8$

Heather wants to make as many biscuits as she can.

Work out how many biscuits Heather can make.

$$20 \times 4.25$$

85

.....
(3)

10. ABC is an isosceles triangle

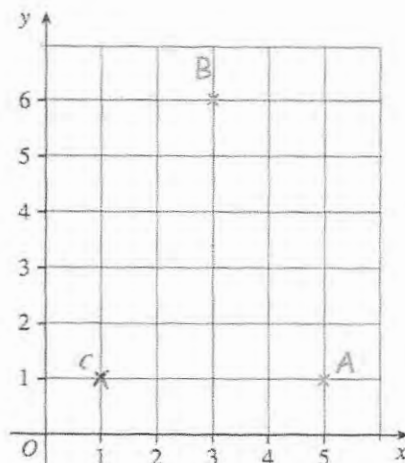

Write down the coordinates of point C

(1, 1)

.....
(3)

11. In one week, Gina spent x minutes on the internet.
Sammy spent 15 minutes less than Gina.

(a) Write down an expression for how long Sammy spent on the internet.

$$\frac{x-15}{\dots\dots\dots} \quad (1)$$

Neil spent three times as long as Gina on the internet.

(b) Write down an expression for how long Neil spent on the internet.

$$\frac{3x}{\dots\dots\dots} \quad (1)$$

(c) Write down an expression for total time spent on the internet.

$$3x + x + x - 15$$
$$5x - 15$$

$$\frac{5x-15}{\dots\dots\dots} \quad (1)$$

12.

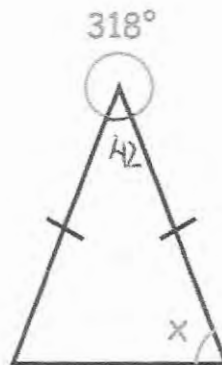

$$180 - 42 = 138$$
$$138 \div 2 = 69$$

Find the size of angle x

$$\frac{69^\circ}{\dots\dots\dots} \quad (3)$$

13.

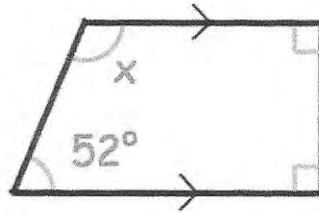

Find the size of angle x

$$90 + 90 + 52 = 232$$

$$360 - 232 = 128^\circ$$

..... 128°
(2)

14. Peterborough Pirates are an ice hockey team.
They play in a league where a win earns 5 points, a draw earns 2 point and a loss earns -1 points.

Peterborough Pirates results

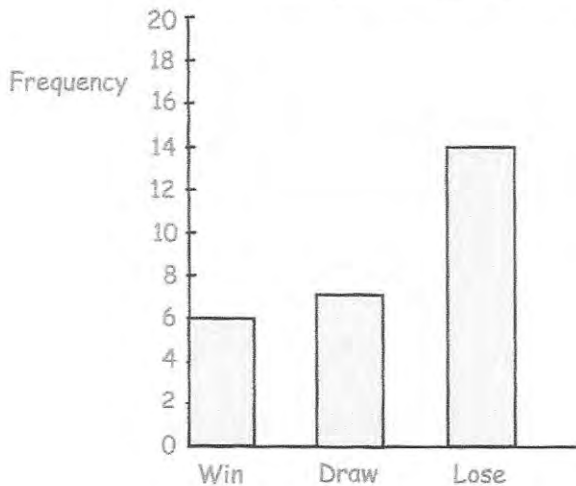

Belfast Giants:	50 points	(3)
Cardiff Devils:	23 points	(9)
Coventry Blaze:	49 points	(4)
Edinburgh Capitals:	51 points	(2)
Manchester Storm:	12 points	(10)
Nottingham Panthers:	28 points	(8)
Sheffield Steelers:	55 points	(1)
Swindon Wildcats:	33 points	(5)
Telford Tigers:	32 points	(6)

The bar chart shows information about their results in 2019.
The table shows the final points for the other 9 teams in the league.

In which position did Peterborough Pirates finish?

$$\left. \begin{array}{l} 6 \times 5 = 30 \\ 7 \times 2 = 14 \\ 14 \times -1 = -14 \end{array} \right\} 30 \text{ points } (7)$$

..... 7^{th}
(4)

15. The diagram below shows a regular hexagon.

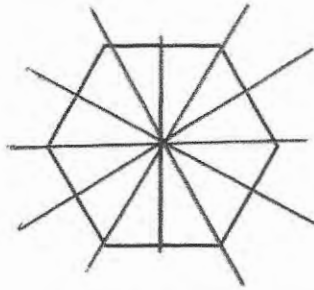

(a) Write down the order of rotational symmetry of the hexagon.

6.....
(1)

(b) On the diagram draw in all the lines of symmetry.

(2)

16. Below is a solid shape.

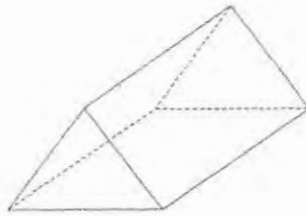

(a) What is the mathematical name for the shape?

Triangular Prism.....
(1)

(b) Write down the number of vertices

6.....
(1)

(c) Write down the number of faces

5.....
(1)

(d) Write down the number of edges

9.....
(1)

17. Here is part of a bus timetable.

Ballymena	15 12	16 12	17 12
Antrim	15 34	-----	17 34
Templepatrick	15 50	-----	17 50
Belfast	16 10	17 00	18 10

58 minutes 48 minutes

Evelyn wants to travel from Ballymena to Belfast.
The 16:12 in an "express bus."

How many minutes shorter is the journey if she takes the "express bus?"

.....10 minutes
(3)

18.

Foxtown			
52	Sandcliff		
70	32	Red Island	
31	14	28	Donhampton

Martin lives in Foxtown.
He works in Donhampton.
Martin drives to work in the morning and back home in the evening.
He works Monday to Friday. 5 days

Work out how many miles Martin drives each week.

$$\begin{array}{r} 31 \\ \times 2 \\ \hline 62 \\ \hline \end{array}$$

$$\begin{array}{r} 62 \\ \times 5 \\ \hline 310 \\ \hline \end{array}$$

.....310..... miles
(3)

19. The table shows the percentage of the vote that the Purple Party received in six general elections.

Year	Percentage
1986	20%
1991	11%
1996	24%
2001	30%
2006	16%
2011	18%

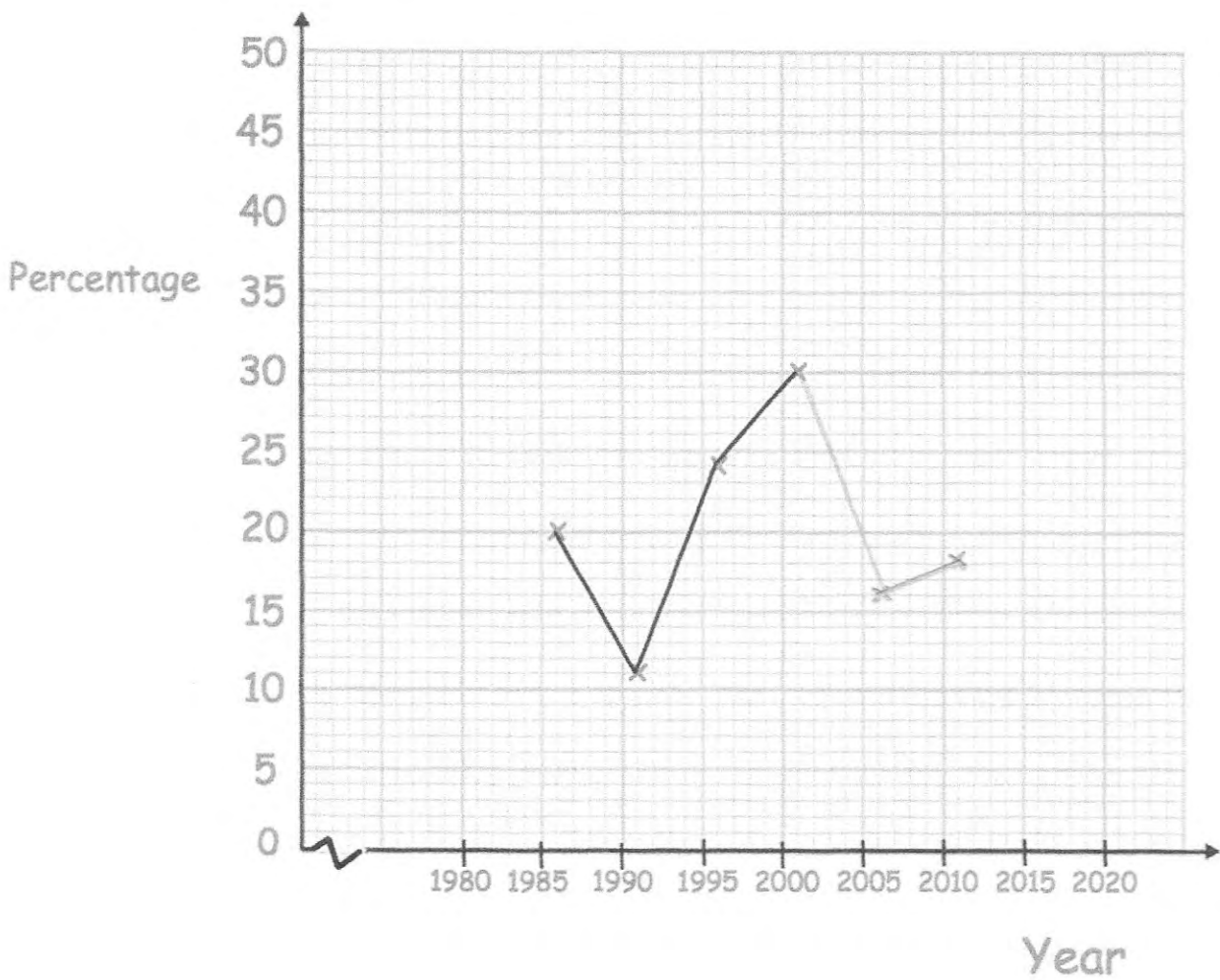

Complete the line graph.

(2)

20.

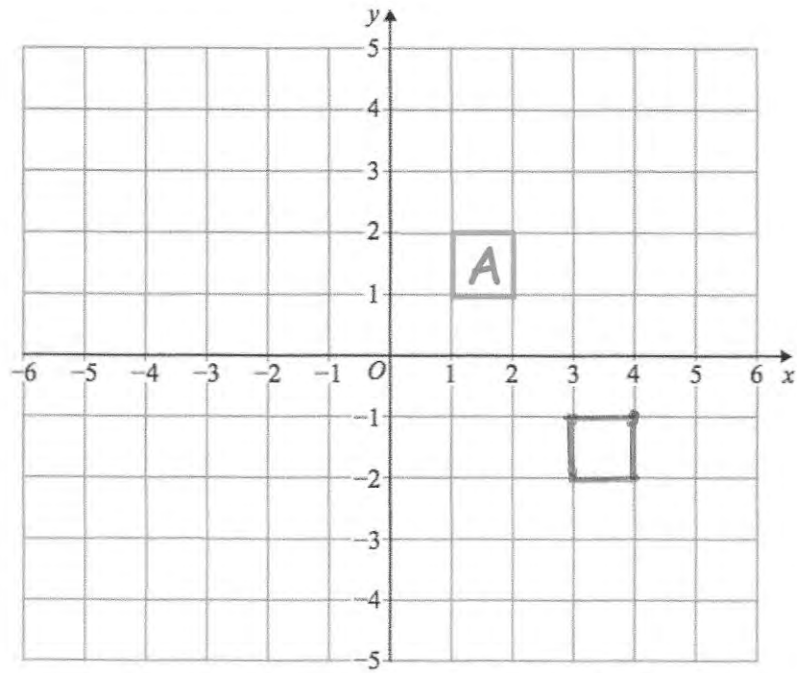

Translate A by $\begin{pmatrix} 2 \\ -3 \end{pmatrix}$

(2)

21. (a) Draw a circle of radius 3cm.

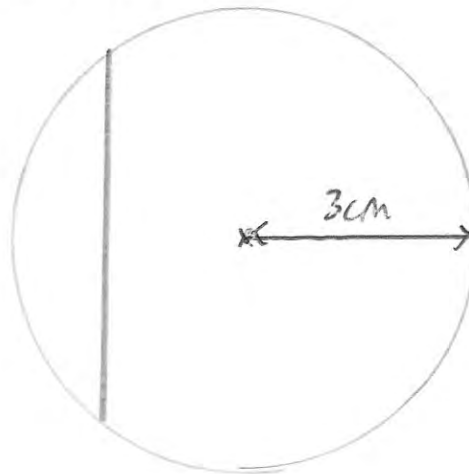

(1)

(b) Write down the length of the diameter of the circle.

.....6.....cm
(1)

(c) On your diagram draw a chord.

(1)

22. Shown is the view of a dice.

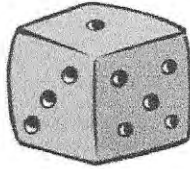

The number of dots on the opposite faces add to 7.

Fill in the missing faces.

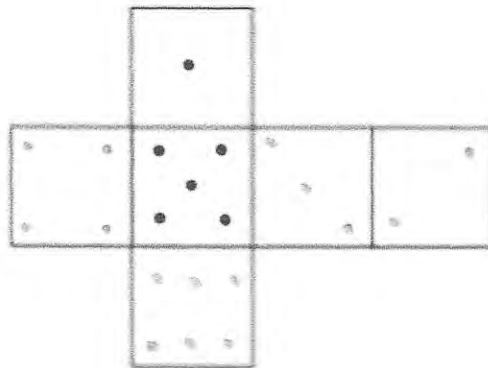

(2)

23.

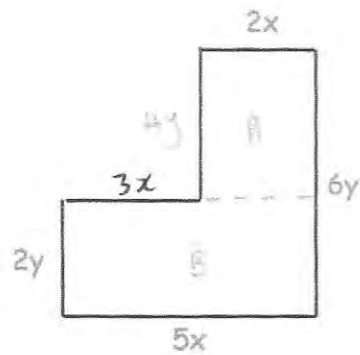

Write down an expression for the area of the shape.

$$\text{Area } A = 8xy$$

$$\text{Area } B = 10xy$$

$$\text{Total} = 18xy$$

$$\underline{18xy}$$

(3)

24. There are 120 students in total in Years 10 and 11 at a school.
Each student studies one language, either French, Spanish, German or Welsh.

21 of the 40 students studying Welsh are in Year 10.

18 Year 10 students and 9 Year 11 students study French.

12 of the 17 students studying Spanish are in Year 11.

Twice as many Year 11 students study German than Year 10 students.

How many students are in Year 11?

	French	Spanish	German	Welsh	Total
Year 10	18	11 5	12	21	56
Year 11	9	12	24	19	64
Total	27	11 17	36	40	120

64

(3)

25. The table below shows information about the number of medals won by 6 countries in an Olympic Games.

Country	Gold	Silver	Bronze	Total
Spain	7	4	6	17
France	10	18	14	42
Germany	17	10	15	42
Italy	8	12	8	28
Japan	12	8	21	41
Australia	8	11	10	29

- (a) Which country won the most silver medals?

France
(1)

- (b) Which country won the same number of gold medals as bronze medals?

Italy
(1)

26. Orla has four types of vegetable.

Peas
Carrots
Turnip
Spinach

Orla is going to choose 2 different types of vegetable.

Write down all the possible combinations of vegetable she can choose.

PC PT PS
CT CS
TS

(2)

27. Simplify $8a + 3c - 5c + 3a$

$$\underline{11a - 2c}$$

(2)

-
28. A set of six numbers have a median of 5.
All of the numbers are even.
The range of the numbers is 6.
The mode of the numbers is 4.

Write down a possible set of six numbers.

$\underline{4}$, $\underline{4}$, $\underline{4}$, $\underline{6}$, $\underline{8}$ and $\underline{10}$

(4)

29. David and Becky want to estimate how many yellow jelly beans are in a tub of 500 jelly beans.
A trial consists of taking a jelly bean at random, noting the colour and replacing the jelly bean in the tub.

	Number of trials	Number of yellow jelly beans chosen
David	20	3
Becky	100	11

- (a) Write down the relative frequency of David taking a yellow jelly bean.

$$\frac{3}{20}$$

.....

(1)

- (b) Write down the relative frequency of Becky taking a yellow jelly bean.

$$\frac{11}{100}$$

.....

(1)

- (c) Whose experiment gives the more reliable estimate of the number of yellow jelly beans in the tub?
Give a reason for your answer.

Becky - more trials

.....

.....

.....

(1)

30. Here is a list of words connected with angles.

Acute

Reflex

Obtuse

Right

Straight

Full-turn

Choose the correct word to describe each angle.



Answer Right..... angle

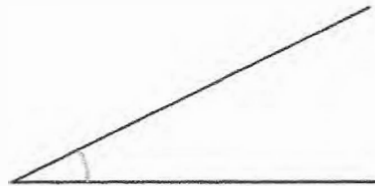

Answer acute..... angle



Answer obtuse..... angle



Answer reflex..... angle

(3)

31. (a) Round the number 7.819 to one decimal place.

7.8.....
(1)

(b) Round the number 7.819 to two decimal places.

7.82.....
(1)

32. Put brackets in the following statements to make them true

(a) $2 \times (7 + 1) \times 3 = 48$

(1)

(b) $(9 + 3^2) \times 10 \div 2 = 90$

(1)

33. A bus to Belfast leaves Antrim Bus Station every 25 minutes.
The first bus each day leaves at 7am.
Darren wants to get a bus after 8am.

What time is the first suitable bus?

25 50 75

1 hour 15 minutes

8:15am.....

(2)

34.

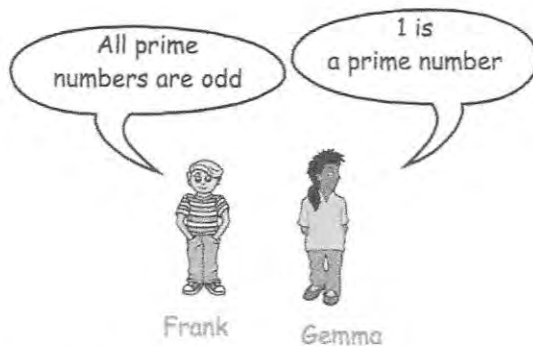

Give a reason why each child is wrong.

Frank: 2 is the only even prime number
so not all primes are odd.

Gemma: 1 is not a prime number.
Prime numbers have two factors, 1 and itself.

(2)

35. William is thinking of two numbers.
Both numbers are square numbers greater than 1.
The sum of the numbers is 100.

Write down the two numbers.

.....36..... and64.....
(2)

36. (a) Express 108 as a product of its prime factors.
Give your answer in index form.

$$\begin{array}{r} 2 \overline{)108} \\ \underline{2} \\ 2 \\ \underline{2} \\ 0 \\ 3 \overline{)27} \\ \underline{3} \\ 0 \\ 3 \overline{)9} \\ \underline{3} \\ 0 \\ 3 \overline{)3} \\ \underline{3} \\ 0 \end{array}$$

$$2 \times 2 \times 3 \times 3 \times 3$$

$$2^2 \times 3^3$$

..... $2^2 \times 3^3$
(3)

- (b) Find the Highest Common Factor (HCF) of 108 and 72.

$$108: 2 \times 2 \times 3 \times 3 \times 3$$

$$72: 2 \times 2 \times 2 \times 3 \times 3$$

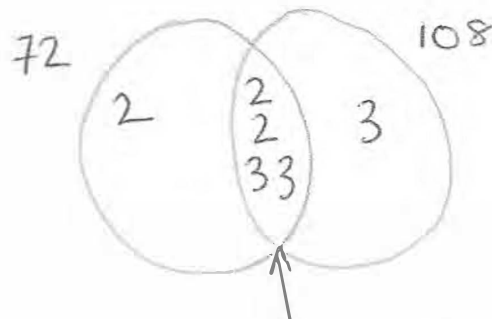

$$\text{HCF: } 2 \times 2 \times 3 \times 3 = 36$$

.....36.....
(2)

37. The size of a packet of pasta is increased by one-quarter.
The new size is later reduced by one-quarter.

Is the new packet smaller, the same size or larger than the original?

Explain how you worked out your answer.

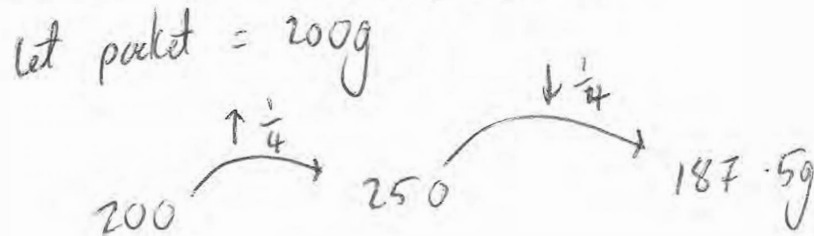

less, the packet is smaller

(3)

38. The table gives information about the number of people voting for each party at an election.

Party	Number of Votes
Gold Party	12598
Pink Party	9112
Brown Party	20059
Purple Party	4466

46235 voted

There are 52852 people who can vote
The target was that 88% of people would vote.

Was the target met?

$$88\% \text{ of } 52852 = 46509.76$$

\therefore target not met.

(3)

39. 1,935 people visit a library during one week.
 The ratio children : adults is 1 : 4
 5 parts
 How many more adults than children visited the library?

$$1935 \div 5 = 387$$

$$387 \times 4 = 1548 \text{ - Adults}$$

$$387 \text{ - Children}$$

1161 more adults
 (3)

40.

$$m = abc$$

Find m if $a = 3$, $b = -8$ and $c = 2$

$$m = (3)(-8)(2)$$

$$= -48$$

$m = -48$
 (2)

41. A game is played with a five sided spinner.
 Each section is a different colour.
 The spinner is biased.
 The table shows some of the probability of the spinner landing on each colour.

Colour	Red	Blue	Green	Pink	Black
Probability	0.34	0.1	0.22	0.22	0.12

The probability of green is equal to the probability of pink.

Calculate the probability the spinner lands on pink.

0.22
 (3)

42.

The table below shows information about the monthly rent of an apartment and the distance of the apartment from a city centre, in miles.

Distance (miles)	3.2	1.5	5.7	8.2	0.7	0.9	4.4	5.8	9.3	0.4
Monthly rent (£)	340	420	250	190	500	470	300	260	170	510

- (a) Plot the data on the scatter graph below.
Clearly label your axes.

(3)

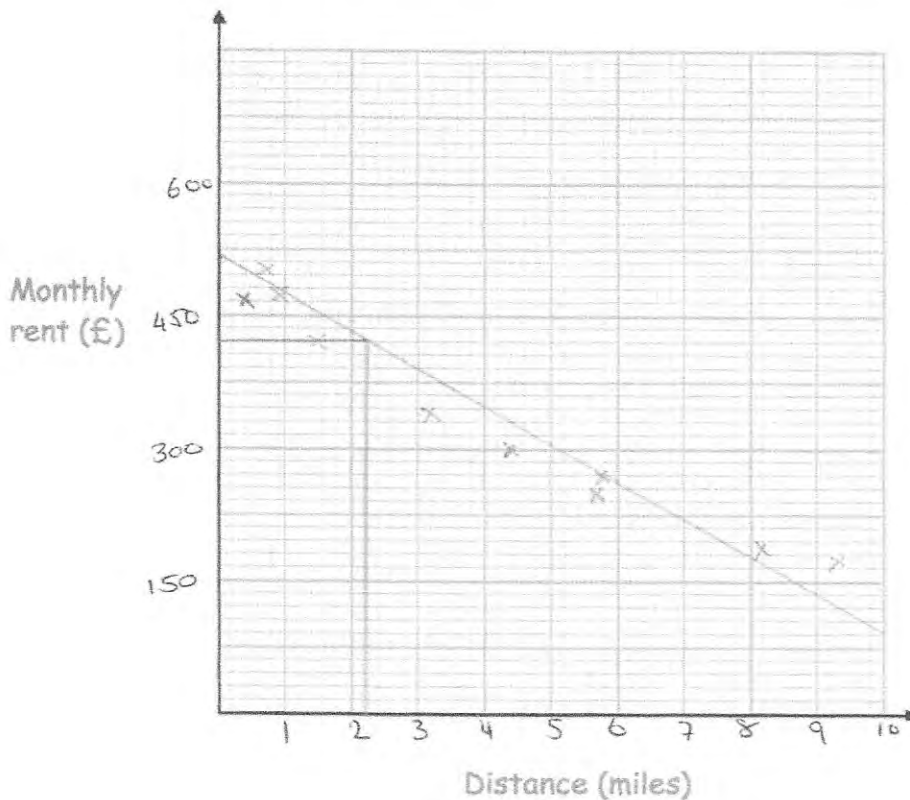

- (b) Describe the relationship between the distance from the city centre and the monthly rent.

The further away from the City centre, the
less the rent

(1)

An apartment is 2.2 miles from the city centre.





- (c) Find an estimate for the monthly rent

£ 420

(2)

2023

43. The number of hours of sunshine on a day, across a number of cities is shown below.

Paris		10 hours
Cork		12 hours
London		7 hours
Swansea		9 hours

Key  represents 4 hours

(a) Which city had the most sunshine?

Cork.....
(1)

(b) How many hours of sunshine did Swansea have?

.....9.....hours
(1)

(c) How many more hours of sunshine did Paris have than London?

.....3.....hours
(1)

44.

124 people took part in a talent show.
Each person either sang or danced.

76 of the people were singers.

14 people made it through to the final and the rest were eliminated.

6 dancers made it through to the final.

Complete the frequency tree

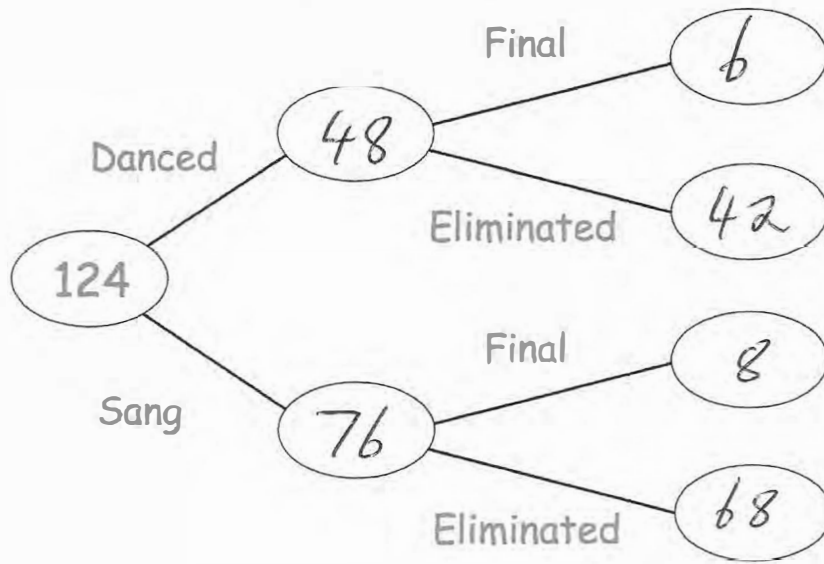

(2)

45. Kelly has two dogs, Pixie and Fifi.

Pixie weighs 8.5 kilograms

Fifi is 720 grams lighter than Pixie.

Work out how much Fifi weighs.

State your units.

$$8.5 \text{ kg} = 8500 \text{ g}$$

$$8500 - 720 = 7780 \text{ g}$$

$$\underline{7.78 \text{ kg}}$$

(3)

46. Below is a right-angled triangle and a rectangle.

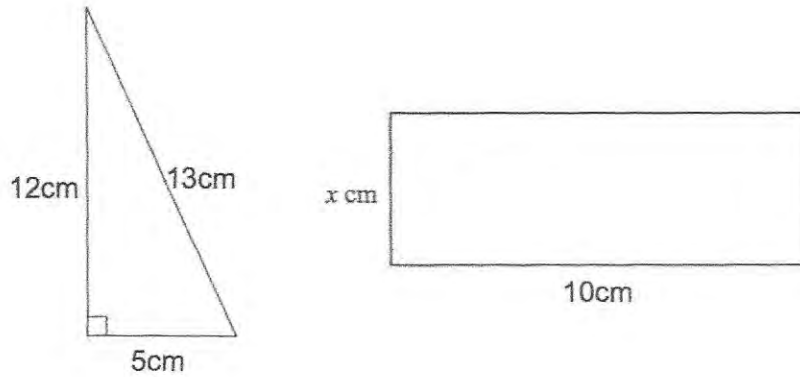

The area of the right-angled triangle is equal to the area of the rectangle.

Calculate x

$$\frac{1}{2}(5 \times 12) = 30 \text{ cm}^2$$

$$10x = 30$$

$$x = 3 \text{ cm}$$

..... 3 cm
(4)

47. Shown below is a regular hexagon ABCDEF.

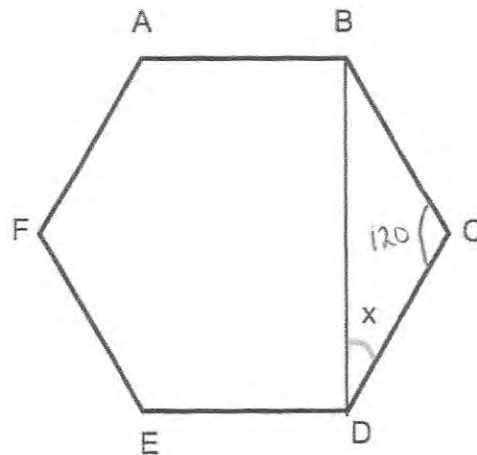

$$720 \div 6 = 120$$

Calculate angle x.

$$180 - 120 = 60$$

$$60 \div 2 = 30$$

x = 30 °
(3)

48. Below are 3 straight lines.

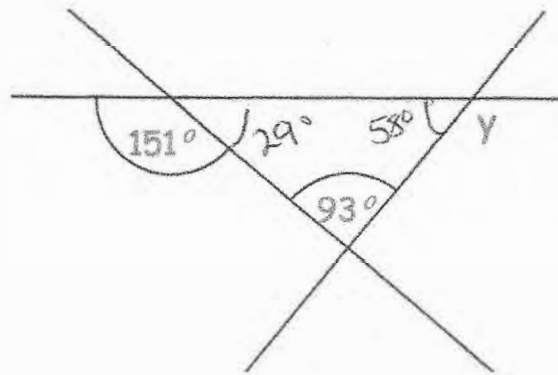

Find the size of angle y .

$$180 - 151 = 29^\circ$$

$$180 - (93 + 29) = 58$$

$$180 - 58 = 122^\circ$$

$$y = 122^\circ \quad (3)$$

- 49.



A village is 20 miles from Belfast.

Conor drives from the village to Belfast at 40mph

Kelly drives from the village to Belfast at 50mph

Work out how much longer the journey takes Conor.

Give your answer in minutes.

$$t = \frac{d}{s}$$

$$\text{Conor: } t = \frac{20}{40} = 0.5 \text{ hours}$$

$$\text{Kelly: } t = \frac{20}{50} = 0.4 \text{ hours}$$

$$0.5 \text{ hours} = 30 \text{ minutes}$$

$$0.4 \text{ hours} = 24 \text{ minutes}$$

$$\dots\dots\dots 6 \text{ minutes} \quad (3)$$

50.

Mass	Frequency	Midpoints	$f \times x$
$20 < m \leq 25$	12	22.5	270
$25 < m \leq 30$	24	27.5	660
$30 < m \leq 35$	17	32.5	552.5
$35 < m \leq 40$	15	37.5	562.5
$40 < m \leq 45$	4	42.5	170
	72		2215

Calculate an estimate of the mean mass.

$$\frac{2215}{72} = 30.763\ldots$$

.....30.8.....kg
(3)

51. There are 80 students in year 11.

9 students study French and German.

35 students only study French

2 students do not study French or German.

(a) Complete the Venn diagram

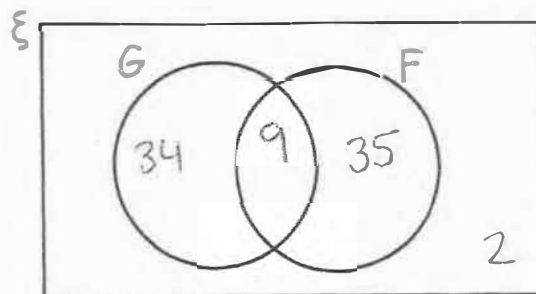

(2)

(b) Work out how many students study only German.

$$80 - 9 - 35 - 2 = 34$$

.....34.....
(1)

52. In a small village, one bus arrives a day.

The probability of rain in the village is 0.3.

If it rains, the probability of a bus being late is 0.4.

If it does not rain, the probability of a bus being late is 0.15.

(a) Complete the tree diagram

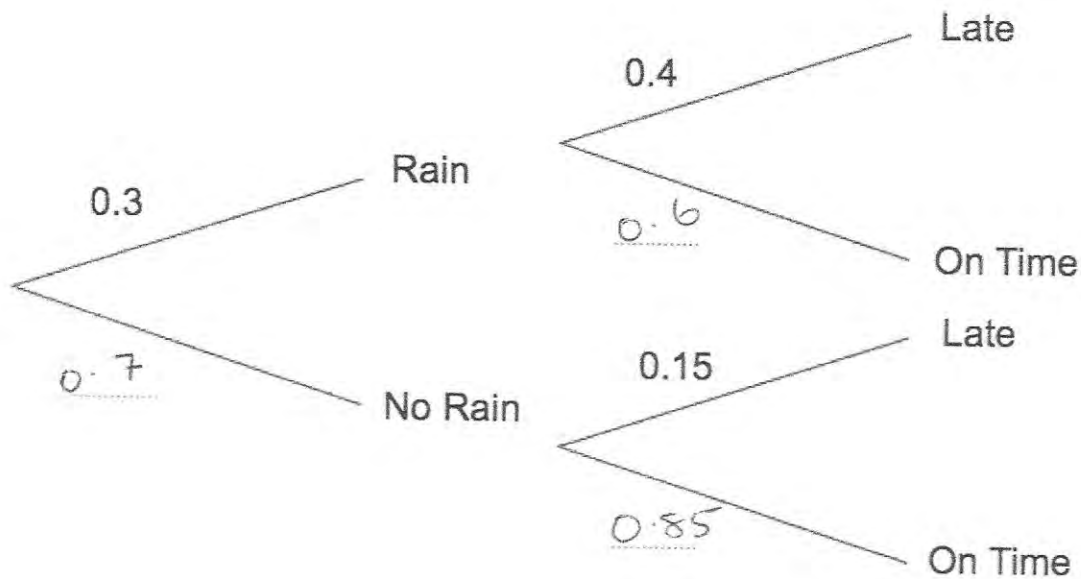

(2)

(b) Work out the number of days the bus will be late over a period of 80 days.

$$P(RL) = 0.3 \times 0.4 = 0.12$$

$$P(NRL) = 0.7 \times 0.15 = 0.105$$

$$0.225$$

$$0.225 \times 80 = 18$$

18 days
(3)

53. Kevin is going on holiday to Japan.
He wants to change some money into yen.

The bank only stocks ¥1000 notes.
James wants to change up to £300 into yen.
He wants as many ¥1000 notes as possible.

The exchange rate is £1 = ¥168

How many ¥1000 notes should he get?

$$300 \times 168 = \text{¥} 50400$$

max ¥50,000 ∴ 50 notes

.....50 notes
(3)

54. On the grid, draw the graph of $y = 3x + 1$ for values of x from -2 to 2

x	-2	-1	0	1	2
y	-5	-2	1	4	7

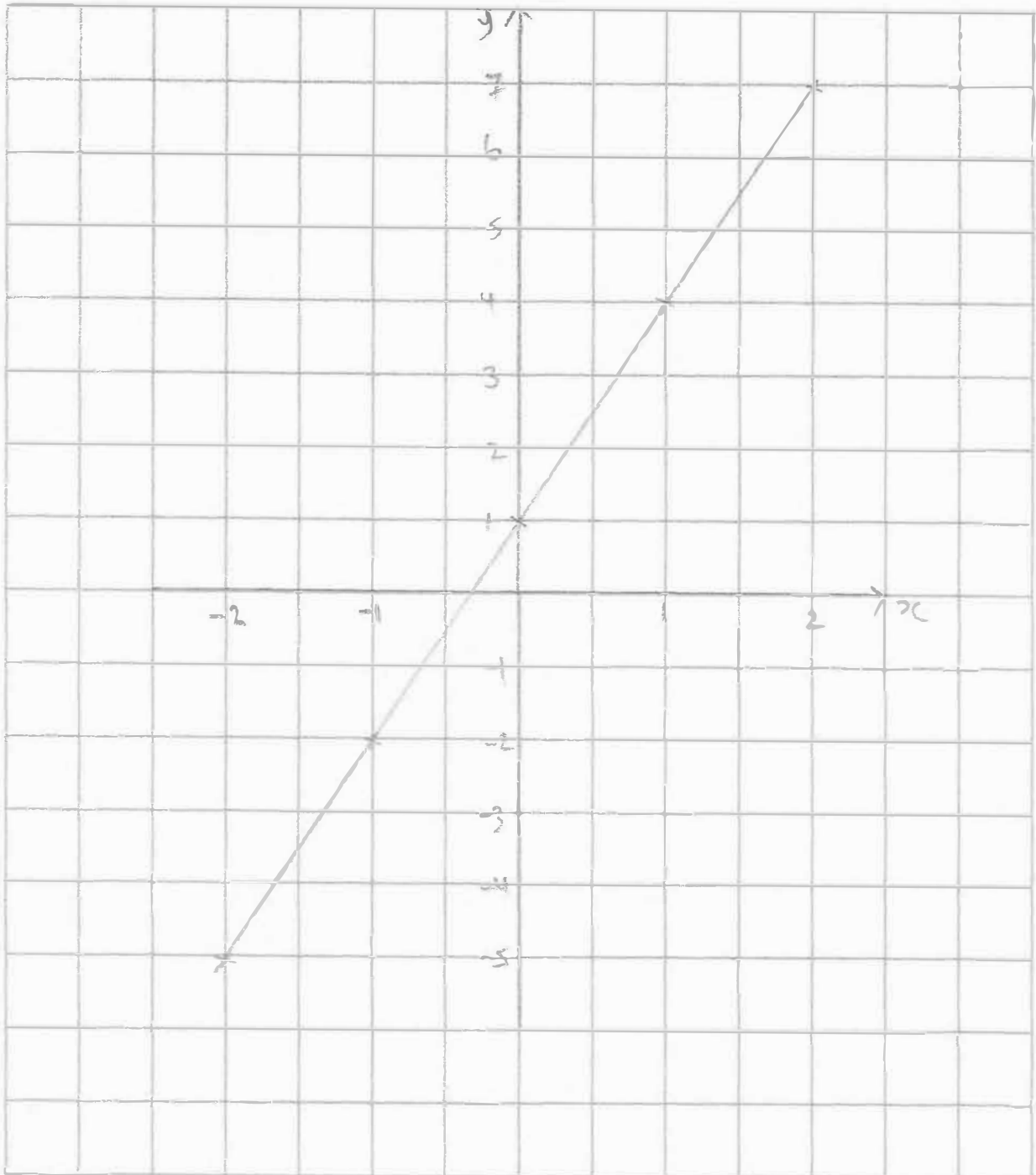

(4)

55. A lamp is on sale at £22.05
This is a 10% reduction of the normal price.

What was the price of the lamp before the reduction?

$$\begin{aligned}90\% &= 22.05 \\1\% &= 0.245 \\100\% &= 24.5\end{aligned}$$

$$\begin{array}{r}24.50 \\ \hline\end{array} \quad (3)$$

56. A box contains yellow beads and blue beads.

The ratio of yellow beads to blue beads in the box is 4 : 5
There are 220 yellow beads in the box.

How many beads are in the box?

$$\begin{aligned}220 \div 4 &= 55 \\55 \times 9 &= 495\end{aligned}$$

$$\begin{array}{r}495 \\ \hline\end{array} \quad (3)$$

57. Alice buys a book for £19.80
A year later she sells the book for £12.87

Calculate the percentage decrease in the value of the book.

$$\frac{6.93}{19.80} \times 100 = 35\%$$

$$\begin{array}{r}35 \\ \hline\end{array} \% \quad (3)$$

58. Work out

$$10^{-2} = \frac{1}{100}$$

Give your answer as a decimal.

$$\underline{\underline{0.01}} \quad (2)$$

59. Expand and simplify $(y - 1)(y - 2)$

$$y^2 - y - 2y + 2$$
$$y^2 - 3y + 2$$

$$\underline{\underline{y^2 - 3y + 2}} \quad (2)$$

60. The diagram below shows a pair of parallel lines.

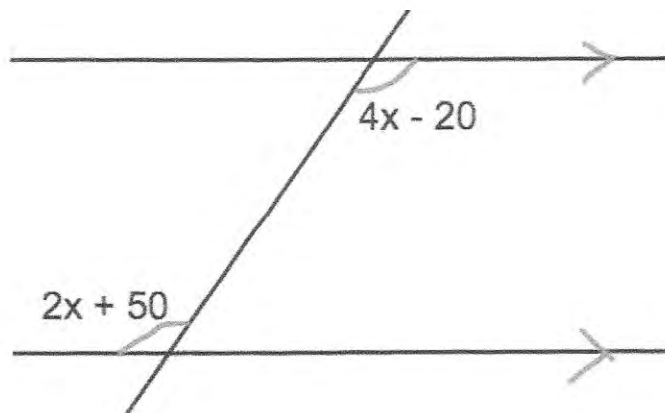

Calculate the size of the angle, $2x + 50$.

$$2(35) + 50 = 120$$

$$4x - 20 = 2x + 50$$

$$2x = 70$$

$$x = 35$$

$$\underline{\underline{120}}^\circ \quad (4)$$

61. Here are the first five terms in a number sequence.

$$7 \quad 10 \quad 13 \quad 16 \quad 19 \quad 22 \quad 25 \quad 28 \quad 31 \quad 34$$

$\underbrace{\quad}_3 \quad \underbrace{\quad}_3 \quad \underbrace{\quad}_3 \quad \underbrace{\quad}_3$

(a) Find the 10th term in this number sequence.

$$3n + 4$$

$$3(10) + 4 = 34$$

$$\dots 34 \dots$$

(2)

(b) Write an expression, in terms of n , for the n th term of this number sequence.

$$\dots 3n + 4 \dots$$

(2)

62. Factorise

$$a^2 + 3a$$

$$a(a+3)$$

$$\dots a(a+3) \dots$$

(1)

63. Factorise $x^2 - 3x - 18$ ~~$x^2 - 3x - 18$~~

$$(x+3)(x-6)$$

$$\dots (x+3)(x-6) \dots$$

(2)

2023

64. A line has equation $y = 3x + 4$

(a) Write down the gradient of the line

3
(1)

(b) Write down the y-intercept of the line

4 or (0,4)
(1)

65. $-4 \leq n < 1$

n is an integer.

(a) Write down all the possible values of n.

-4, -3, -2, -1, 0
(2)

(b) Solve the inequality $4x + 11 < 27$

$$4x < 16$$

$$x < 4$$

$x < 4$
(2)

66.

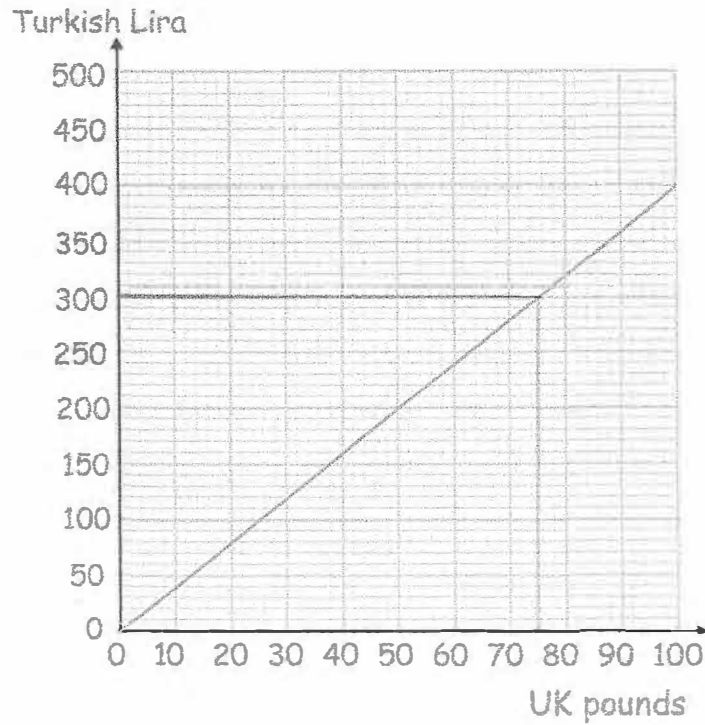

Richard has ₺300 and £800.
He buys a flight that costs ₺900

He pays use the ₺300 and some of the pounds.

Work out how many pounds he has left.

$$900 - 300 = 600$$

$$300 \text{ turkish lira} = \pounds 75$$

$$600 \text{ turkish lira} = \pounds 150$$

$$800 - 150 = 650$$

$$\pounds \underline{650} \dots\dots\dots$$

(3)

67. Factorise $c^2 - 36$

$$(c + 6)(c - 6)$$

$$\underline{(c + 6)(c - 6)}$$

(1)

68. Fiona leaves £1600 in the bank for four years.
It earns compound interest of 4% each year.

Calculate the total amount Fiona has in the bank at the end of the four years.

$$1600 \times 1.04^4 = 1871.7736..$$

£1871.77...
(3)

69. The table gives the circumference, in metres, of planets in the solar system.
The circumferences are given to an accuracy of 3 significant figures.

Planet	Circumference (metres)
Mercury	1.54×10^7
Venus	3.81×10^7
Earth	4.01×10^7
Mars	2.13×10^7
Jupiter	4.39×10^8
Saturn	3.66×10^8
Uranus	1.59×10^8
Neptune	1.55×10^8

- (a) Which planet has the largest circumference?

Jupiter.....
(1)

- (b) Which planet has the smallest circumference?

Mercury.....
(1)

- (c) Write 1.54×10^7 as an ordinary number.

154 00 000.....
(1)

70.

(a) Complete the table of values for $y = x^3 + 2x^2 - 1$

x	-3	-2	-1	0	1	2
y	-10	-1	0	-1	2	15

(2)

(b) On the grid, draw the graph of $y = x^3 + 2x^2 - 1$ for the values of x $-3 \leq x \leq 2$

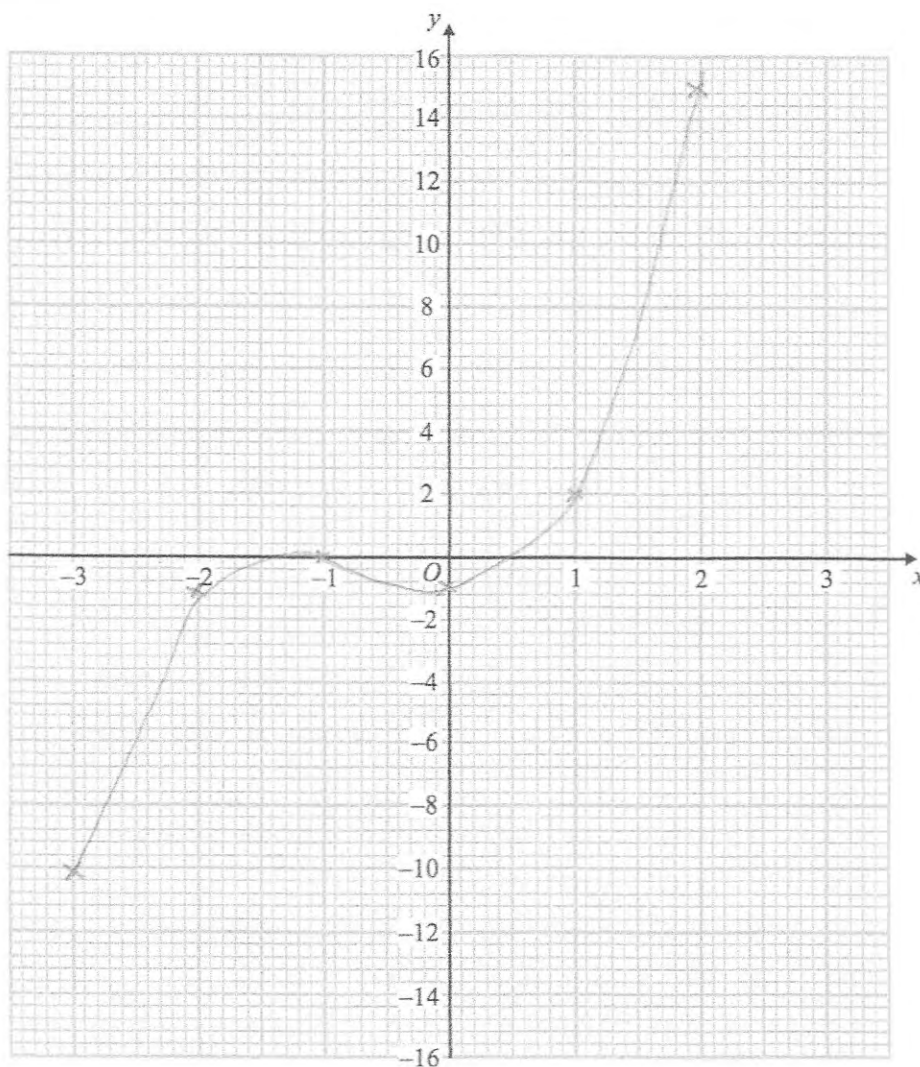

(2)

71. (a) Complete the table of values for $y = \frac{2}{x}$

x	-5	-2	-1	-0.5	0.5	1	2	5
y	-0.4	-1	-2	-4	4	2	1	0.4

(2)

(b) On the grid, draw the graph of $y = \frac{2}{x}$ for $0.5 \leq x \leq 10$

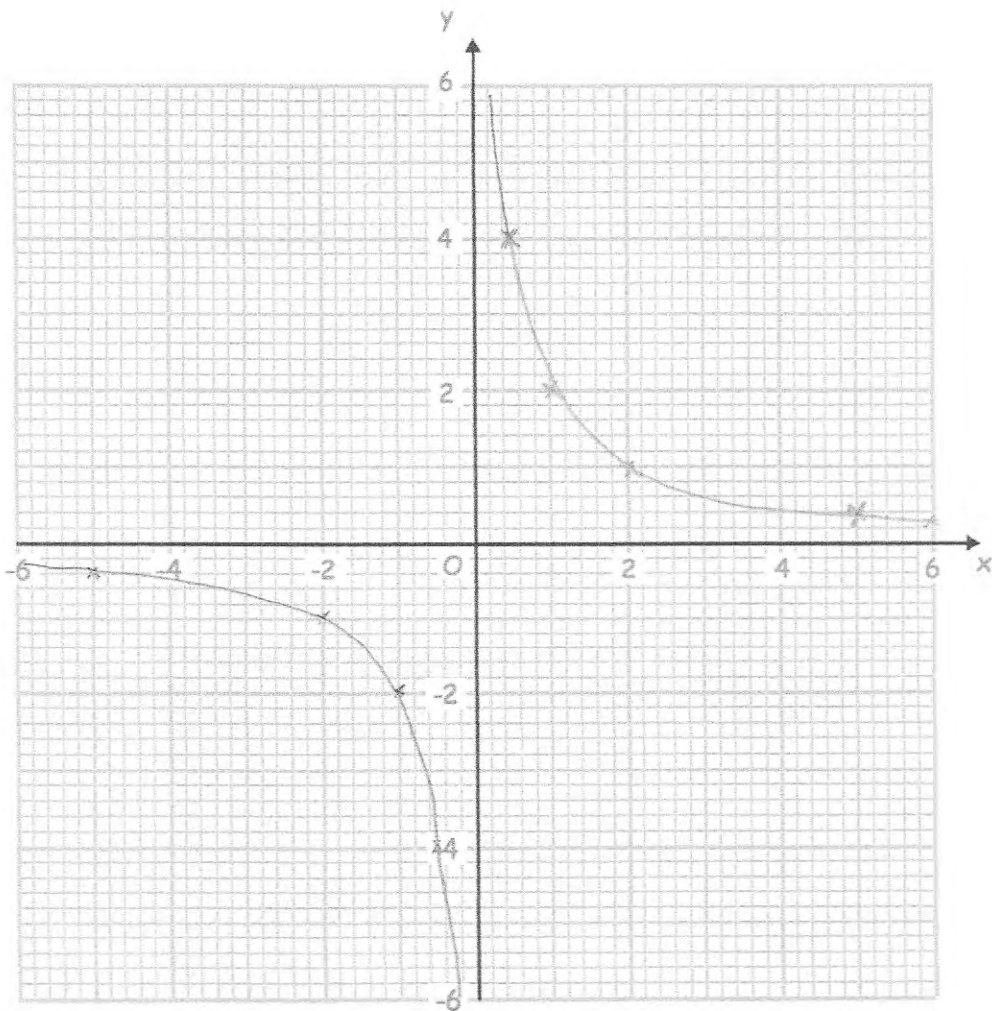

(2)

72.

AB is parallel to CD.

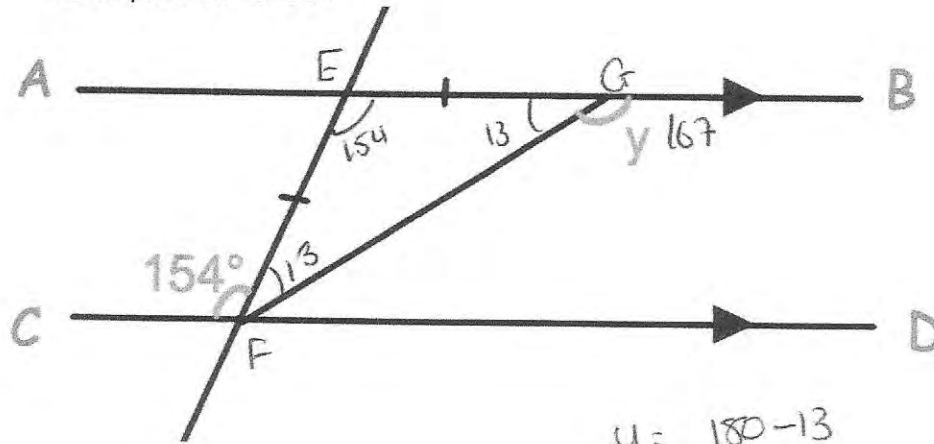

$$y = 180 - 13 \\ = 167^\circ$$

Work out the size of angle y .
Give reasons for your answer.

$\hat{C}FE = \hat{F}EG$ as they are alternate angles

The triangle is isosceles therefore $\hat{E}FG$ and $\hat{E}GF$ are equal.

Angles in triangle add to 180° so $180 - 154 = 26^\circ$

$$26 \div 2 = 13^\circ$$

Angles EGF and BGF are in a straight line so they must add to 180° , so $y = 167^\circ$

.....167.....
(4)

73. Use ruler and compasses to construct the perpendicular bisector of AB. You **must** show clearly all your construction arcs.

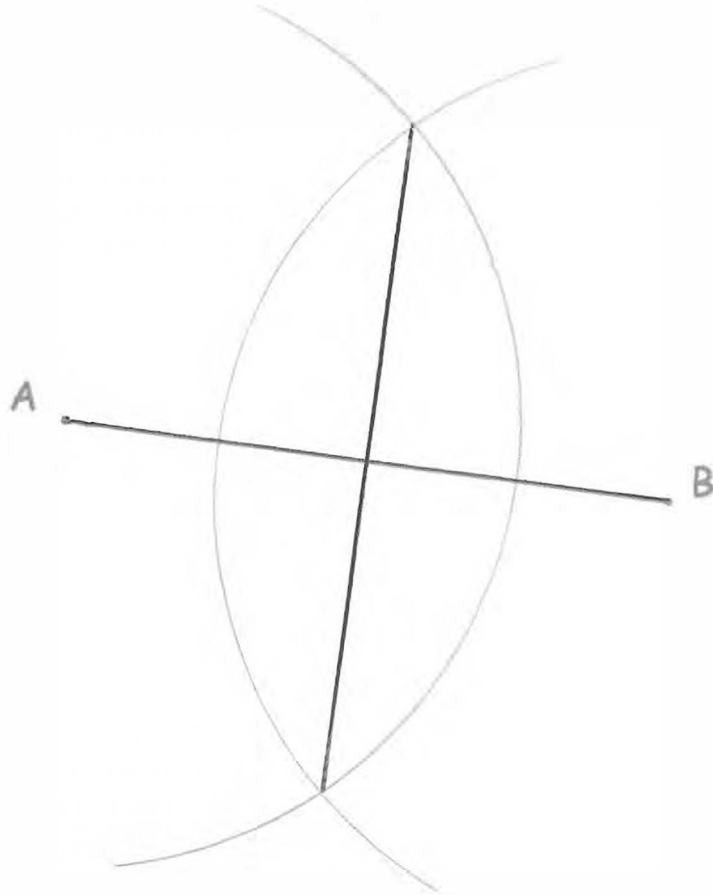

(2)

74. Below is a diagram of a hall.
There is a front door at one end of the hall and a patio door at the other.
There are two burglar alarm sensors, one at A and one at B.

The range of each sensor is 4m.

1cm = 1 metre

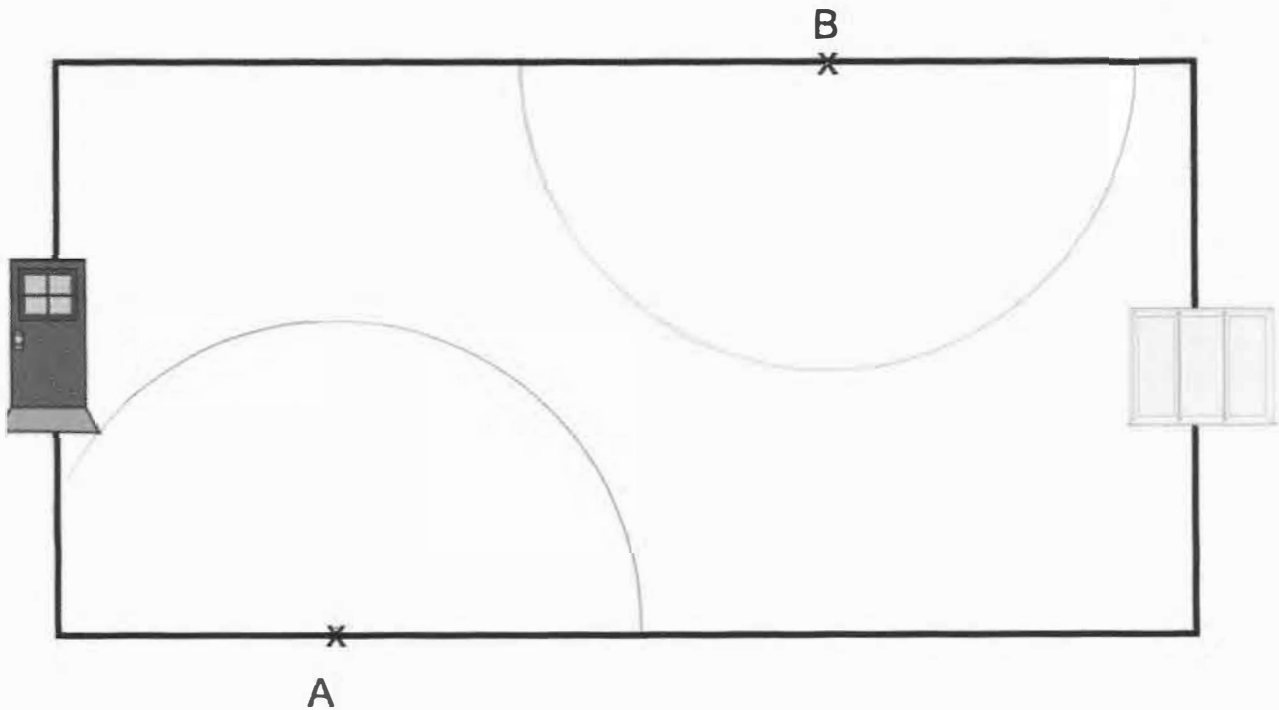

The alarm is switched on.

Is it possible to walk from the front door to the patio door without setting off the alarm?

Yes.....

(3)

75.

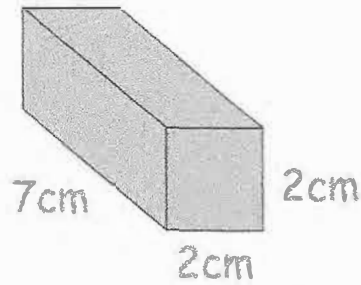

Find the surface area of this cuboid.
Include suitable units.

$$\begin{aligned}
 2 \times 2 &= 4\text{cm}^2 & 7 \times 2 &= 14\text{cm}^2 \\
 4 \times 2 &= 8\text{cm}^2 & 14 \times 4 &= 56\text{cm}^2 \\
 56 + 8 &= 64\text{cm}^2
 \end{aligned}$$

$$\dots\dots\dots 64\text{cm}^2 \dots\dots\dots (3)$$

76. A solid silver spoon has a mass of 65.1g.
The volume of the spoon is 6.2cm³.
Calculate the density of silver.

$$\rho = \frac{m}{V} = \frac{65.1}{6.2} = 10.5$$

$$\dots\dots\dots 10.5 \dots\dots\dots \text{g/cm}^3 \dots\dots\dots (2)$$

77. A cylinder is placed on a table.
The cylinder has a weight of 400N and has a diameter of 10cm.

Work out the pressure on the table in newtons/cm²

$$P = \frac{F}{A} = \frac{400}{25\pi} = 5.0929\dots$$

$$\begin{aligned}
 \text{Area} &= \pi r^2 \\
 &= \pi (5^2) \\
 &= 25\pi
 \end{aligned}$$

$$\dots\dots\dots 5.09 \dots\dots\dots \text{N/cm}^2 \dots\dots\dots (2)$$

78. Shown below is a triangular prism.

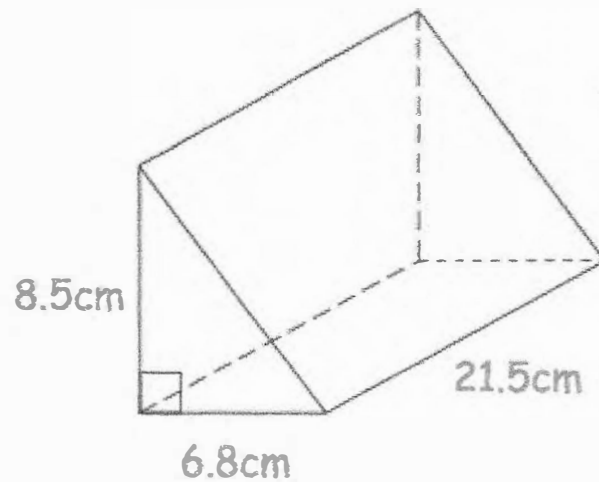

Find the volume of the triangular prism.

$$\frac{1}{2}(6.8 \times 8.5) = 28.9$$

$$28.9 \times 21.5 = 621.35$$

.....621.35.....cm³
(3)

79.

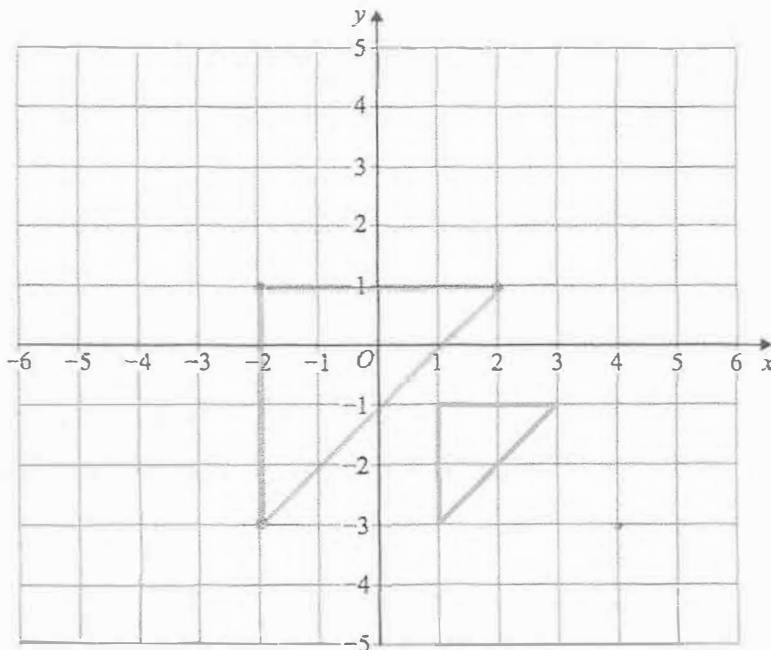

Enlarge by scale factor 2 using
(4, -3) as the centre of enlargement

80.



Work out the circumference of the circle.
Give your answer to 1 decimal place.

$$C = \pi d$$

$$d = 18$$

$$C = 18\pi$$

$$C = 56.548\dots$$

56.5

~~18\pi~~ cm
(2)

81. The diagram below shows a shape made with centimetre cubes.

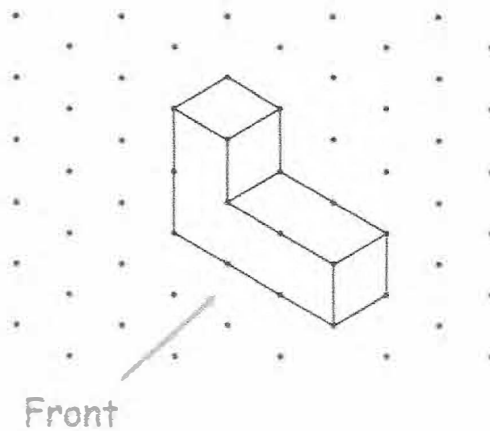

(a) On the centimetre square grid, draw the front elevation.

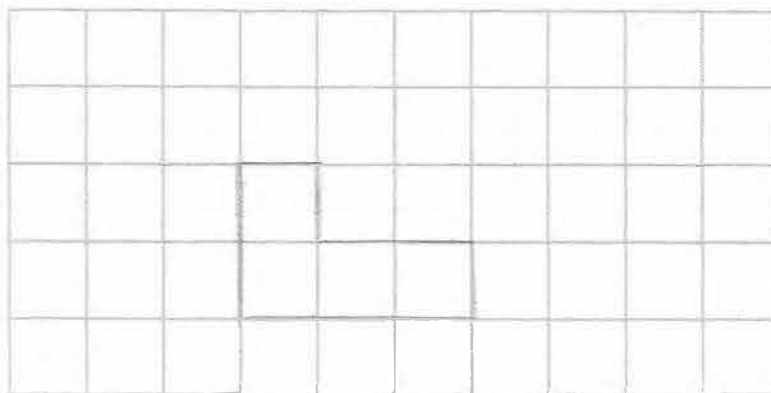

(2)

(b) On the centimetre square grid, draw the plan view.

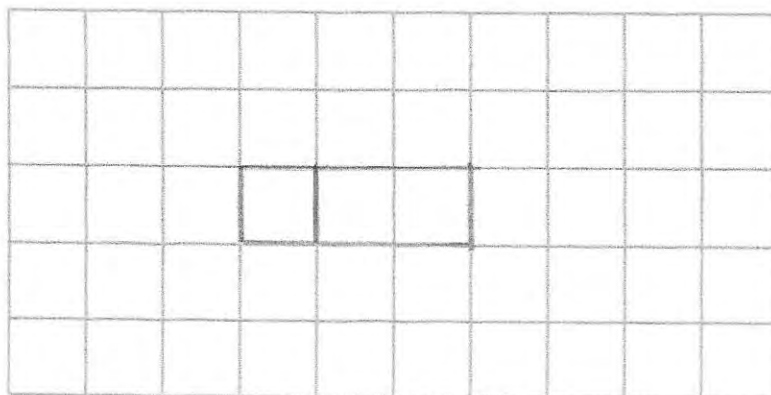

(2)

82.

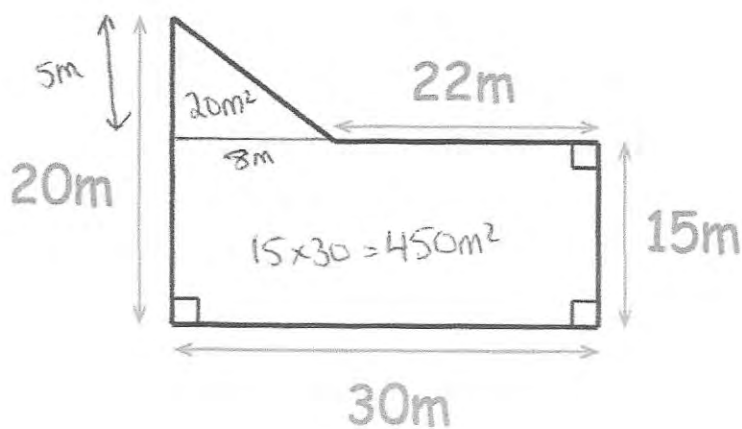

Calculate the area of the field.

$$450 + 20 = 470 \text{ m}^2$$

..... 470 m²
(2)

83.

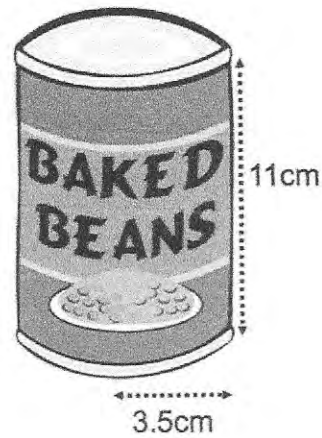

Calculate the volume of the can.

$$\pi \times 3.5^2 \times 11$$

$$= 423.3296 \dots$$

$$\dots 423.33 \dots \text{ cm}^3$$

(3)

84.

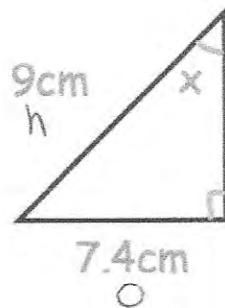

Find the size of angle x

$$\sin x = \frac{7.4}{9}$$

$$x = \sin^{-1}\left(\frac{7.4}{9}\right)$$

$$x = 55.3078 \dots$$

$$\dots 55.31^\circ \dots$$

(3)

85.

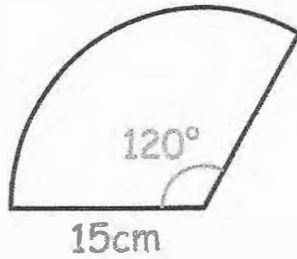

$$P = 15 + 15 + 31.4159 \dots$$

$$P = 61.4159 \dots$$

Calculate the perimeter.

$$\frac{120}{360} \times \pi \times 30$$

$$= \frac{1}{3} \pi \times 30$$

$$= 31.4159 \dots$$

..... 61.42 cm
(3)

86.

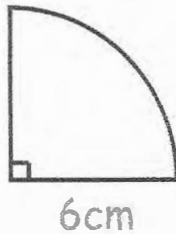

Calculate the area.

$$\frac{90}{360} \times \pi \times 6^2$$

$$\frac{1}{4} \pi \times 36$$

$$= 28.27$$

..... 28.27 cm²
(3)

87. Shown is a sphere with radius 8cm.



$$SA = 4\pi(8)^2$$

$$SA = 804.2477193$$

Calculate the surface area of the sphere.

..... 804.25 cm²
(3)

88. A cone has base diameter 8cm.
The height of the cone is 9cm.

Calculate the volume of the cone.

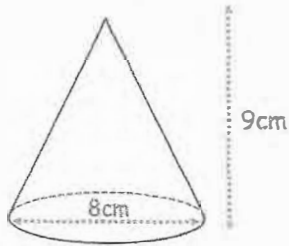

$$V = \frac{1}{3} \pi (4)^2 \times 9$$

$$V = 150.796$$

.....150.8.....cm³
(3)

-
89. Given $\mathbf{a} = \begin{pmatrix} 3 \\ 0 \end{pmatrix}$ $\mathbf{b} = \begin{pmatrix} 2 \\ 7 \end{pmatrix}$

Work out $2\mathbf{a} + \mathbf{b}$

$$\begin{pmatrix} 6 \\ 0 \end{pmatrix} + \begin{pmatrix} 2 \\ 7 \end{pmatrix}$$

$$= \begin{pmatrix} 8 \\ 7 \end{pmatrix}$$

..... $\begin{pmatrix} 8 \\ 7 \end{pmatrix}$
(3)

90.

Reflect shape A in the line $x = 1$

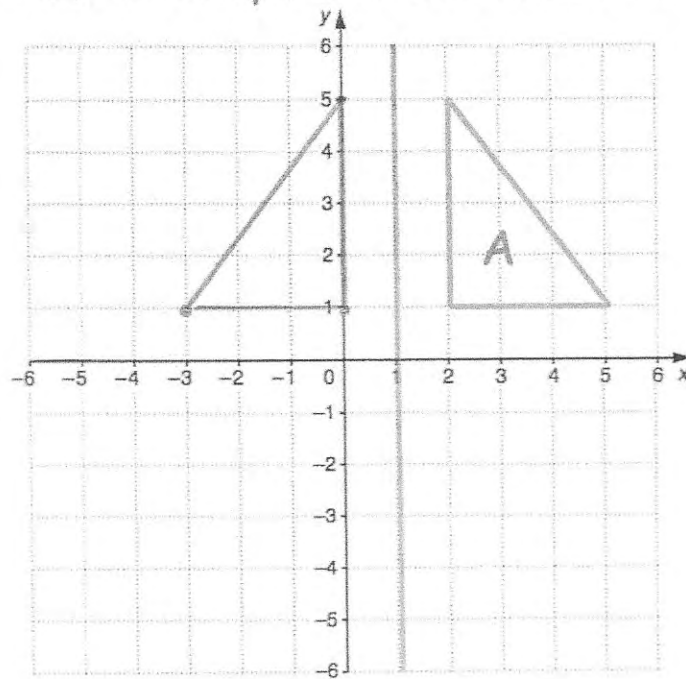

91.

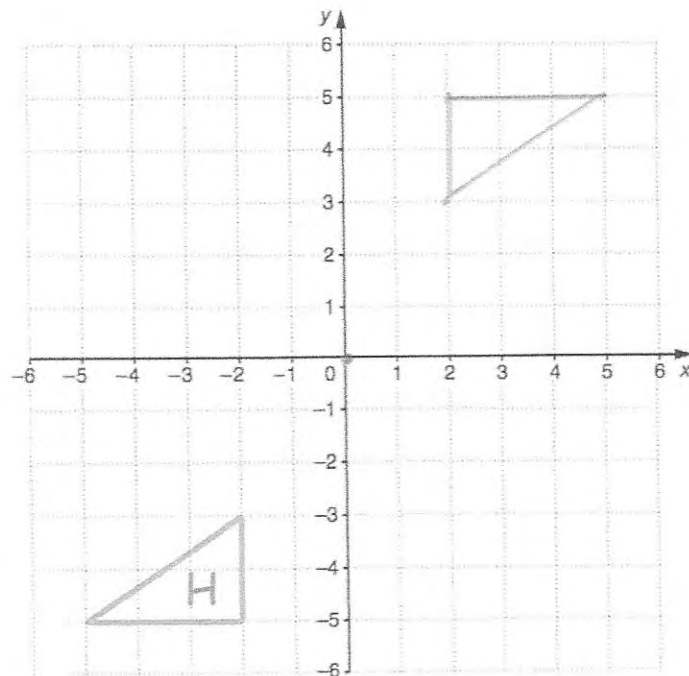

rotate 180° about $(0, 0)$

92. Shown below are six triangles that are not drawn accurately.

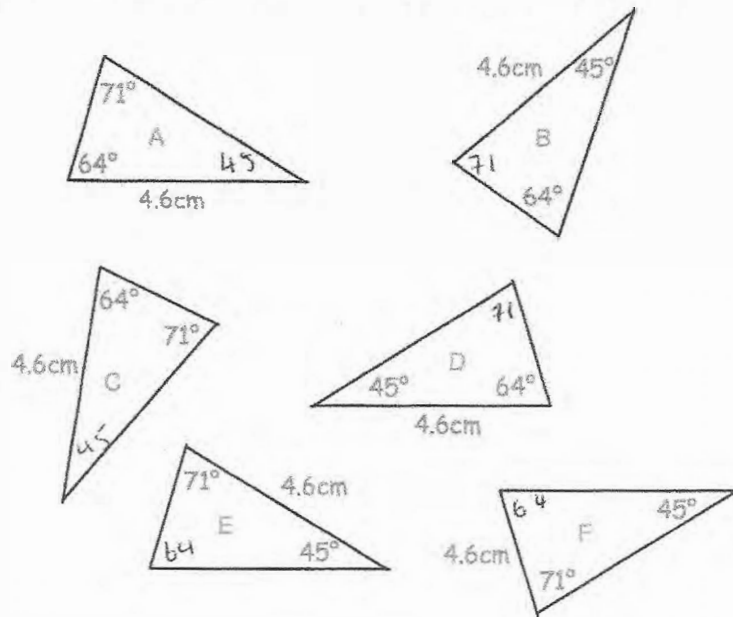

Which two triangles are congruent to triangle A?

..... C and D
(2)

93. Shown below are two similar triangles.

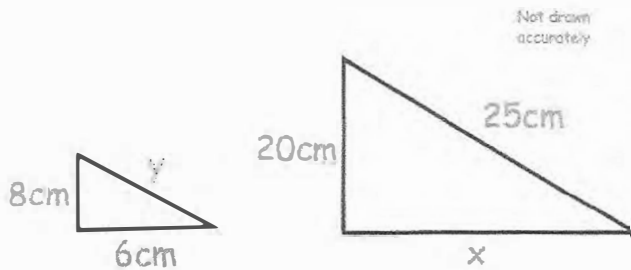

(a) Find the size of x.

$$\frac{20}{8} = \frac{x}{6} \quad x = 15$$

$$8x = 120$$

..... 15 cm
(2)

(b) Find the size of y.

$$\frac{20}{8} = \frac{25}{y} \quad 20y = 200$$

$$y = 10$$

..... 10 cm
(2)

94. (a) Complete the table of values for $y = x^2 + 2x + 1$

x	-3	-2	-1	0	1	2	3
y	4	1	0	1	4	9	16

(2)

(b) On the grid, draw the graph of $y = x^2 + 2x + 1$ for the values of x from -3 to 3.

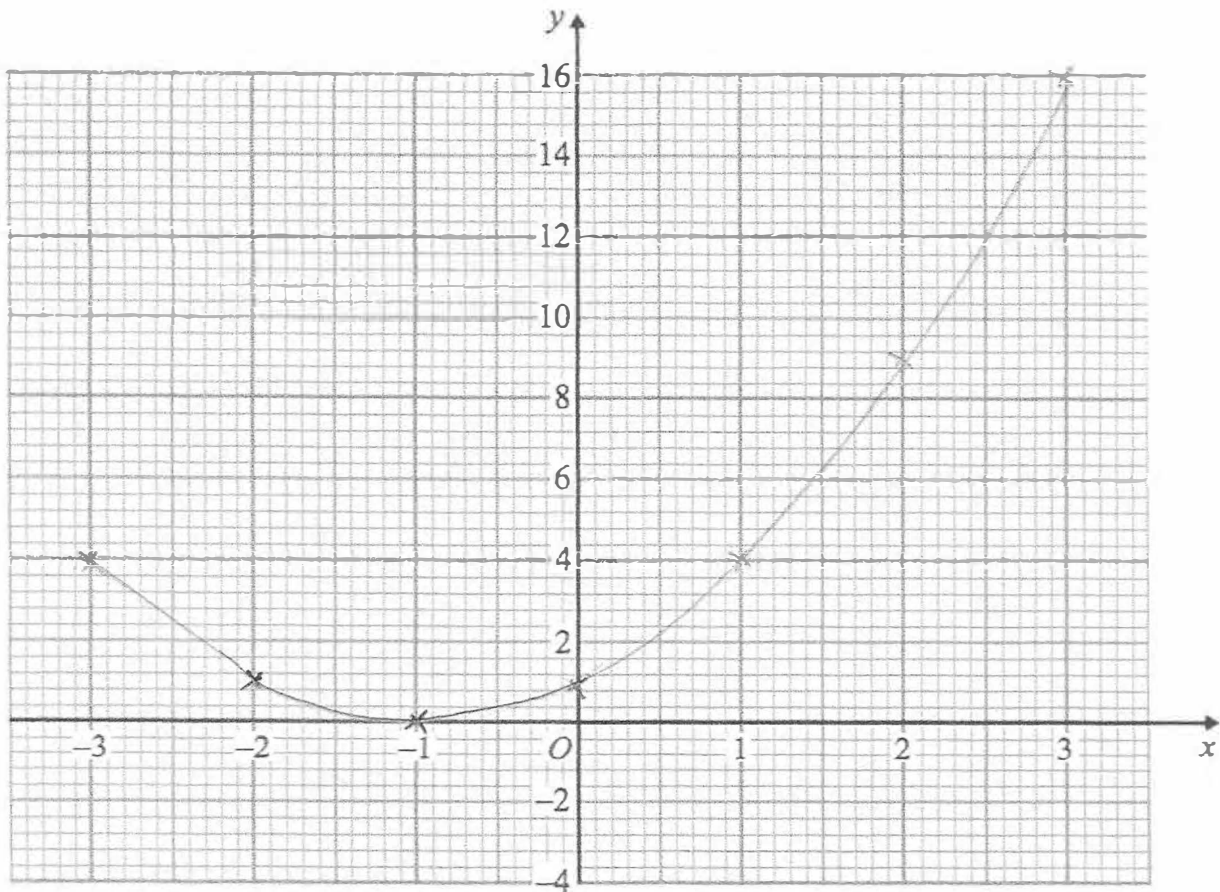

(2)

95. Solve the simultaneous equations

$$3x + 2y = 16 \quad (1) \times 2$$

$$2x - 3y = 2 \quad (2) \times 3$$

Do not use trial and improvement

$$\begin{array}{r} 6x + 4y = 32 \\ \rightarrow 6x - 9y = 6 \\ \hline 13y = 26 \\ y = 2 \end{array}$$

$$\begin{array}{l} 3x + 2(2) = 16 \\ 3x = 12 \\ x = 4 \end{array}$$

$$x = \underline{4} \dots\dots\dots y = \underline{2} \dots\dots\dots \quad (4)$$

96. Make v the subject of

$$t = \frac{v}{4} + 1$$

$$\frac{v}{4} = t - 1$$

$$v = 4(t - 1)$$

$$v = \underline{4(t-1)} \dots\dots\dots \quad (2)$$

or

$$v = 4t - 4$$

97. Sarah is x years old.
 Thomas is 3 years older than Sarah.
 David is twice as old as Sarah.
 The total of their ages is 51.

(a) Write an expression for Thomas's age in terms of x .

$$\frac{x + 3}{\dots\dots\dots} \quad (1)$$

(b) Write an expression for David's age in terms of x .

$$\frac{2x}{\dots\dots\dots} \quad (1)$$

(c) Form an equation in x and solve it to work out Sarah's age.

$$\begin{aligned} x + x + 3 + 2x &= 51 \\ 4x + 3 &= 51 \\ 4x &= 48 \\ x &= 12 \end{aligned}$$

$$\frac{12}{\dots\dots\dots} \quad (2)$$

98. Write down the equation of the line that is parallel to $y = 6x + 1$ and passes through $(0, 8)$.

~~$y = 6x + 1$~~
 $8 = c$
 $y = 6x + 8$

$$\frac{y = 6x + 8}{\dots\dots\dots} \quad (2)$$

99. The table gives information about the meals ordered on a Sunday.

Meal	Frequency	Angle
Chicken	14 x 4	56°
Beef	9 x 4	36°
Pork	57 x 4	228°
Vegetarian	10 x 4	40°

$$360 \div 90 = 4^\circ$$

90

Draw an accurate pie chart to show this information.

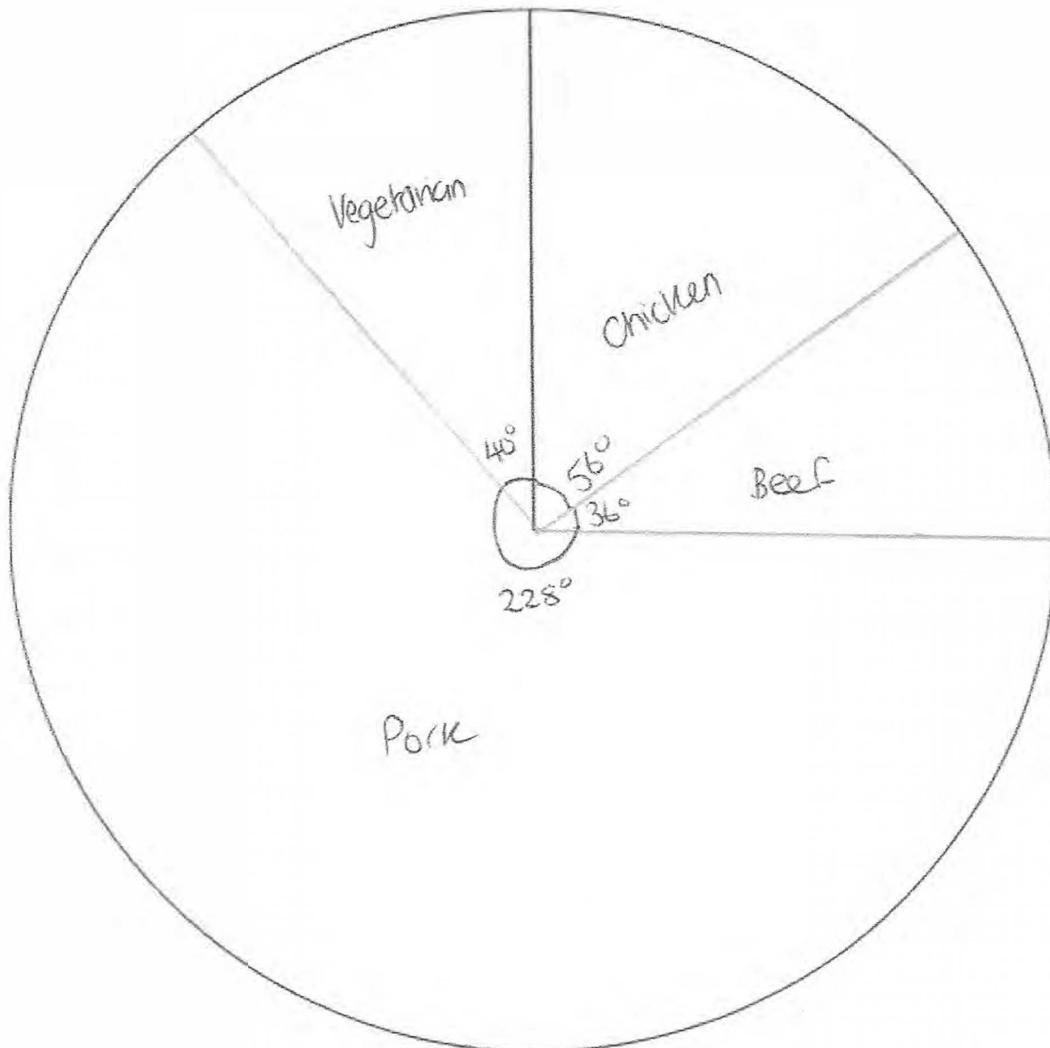

(4)

100. Simplify the following.

$$\frac{s^3 \times s^4}{s^2} = \frac{s^7}{s^2} = s^5$$

s^5

(2)

101. Work out the gradient of the line passing through (0, 2) and (4, 14)

$$\frac{14-2}{4-0} = \frac{12}{4}$$

3

(1)

102. Below are two triangles, ABC and BCD.

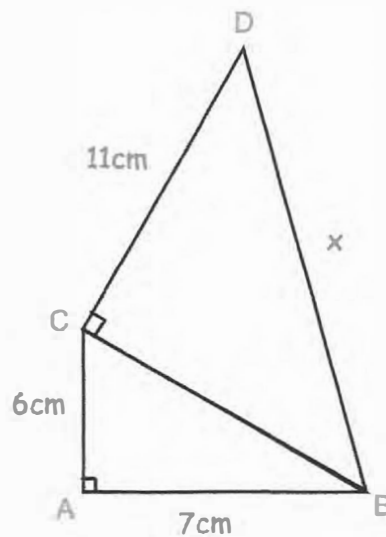

Find x

$$\begin{aligned} 6^2 + 7^2 &= BC^2 \\ 36 + 49 &= BC^2 \\ 85 &= BC^2 \\ BC &= \sqrt{85} \end{aligned}$$

$$\begin{aligned} BC^2 + 11^2 &= BD^2 \\ 85 + 121 &= BD^2 \\ BD &= \sqrt{206} \end{aligned}$$

14.35

cm
(4)

103. Shown is a circle with radius 5cm.

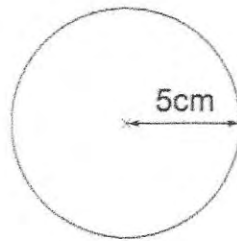

Work out the area of the circle.

$$A = \pi r^2$$

State the units for your answer.

$$A = \pi(25)$$

Give your answer to 2 decimal place.

$$A = 78.5398$$

$$\underline{\underline{78.54 \text{ cm}^2}}$$

(3)

104. The map below shows the position of two towns.

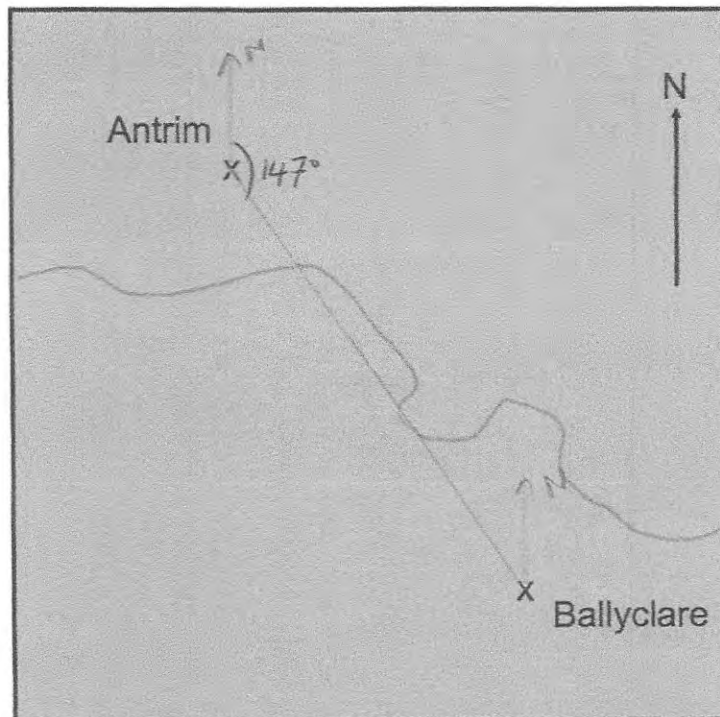

Find the bearing of Ballyclare from Antrim.

$$\underline{\underline{147^\circ}}$$

(1)

105.

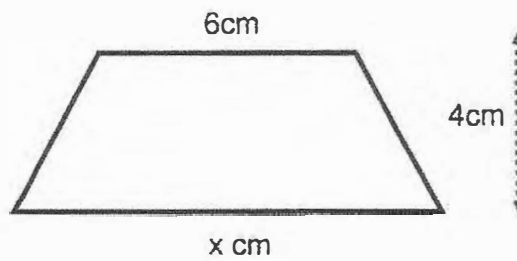

The area of the trapezium is 34cm^2 .

Work out the value of x .

$$\frac{1}{2}(a+b) \times h$$

$$\frac{1}{2}(6+x) \times 4 = 34$$

$$(6+x) \times 4 = 68$$

$$6+x = 17$$

$$x = 11$$

.....11.....cm
(2)

106. A number, n , is rounded to 1 decimal place.
The result is 1.8

✓

Using inequalities, write down the error interval for n .

$$1.75 \leq n < 1.85$$

1.75 ≤ n < 1.85
(3)

107. There are two different packets of the same type of paper in a shop.

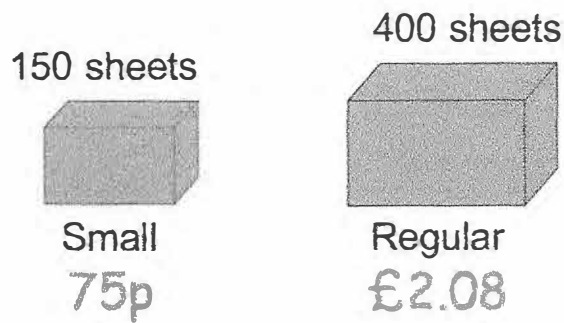

Which of the two packets gives the better value for money?
You must show your working.

$$\text{LCM of } 150 \text{ and } 400 = 1200$$

$$\begin{array}{l} £0.75 \times 8 = £6 \\ £2.08 \times 3 = £6.24 \end{array} \left. \vphantom{\begin{array}{l} £0.75 \times 8 = £6 \\ £2.08 \times 3 = £6.24 \end{array}} \right\} \text{Therefore the small packet} \\ \text{is better value.}$$

(4)

108. Use your calculator to work out the value of

$$\sqrt[3]{(25.4 - 5.9)^2}$$

Give your answer to 3 decimal places.

$$\underline{\underline{7.245}}$$

(3)

109. Geraint has 2p and 50p coins in the ratio 20 : 3

Write the ratio of the value of the 2p coins to the value of 50p coins in its simplest form.

$$2 \times 20 = 40$$

$$50 \times 3 = 150$$

$$40 : 150$$

$$4 : 15$$

$$4 : 15$$

.....
(3)

110. There are 10 students in Class 1 and 20 students in Class 2.
All 30 students sit a test.

The mean score for the students in Class 1 was 80%

The mean score for the students in Class 2 was 70%

Find the mean score of all the students.

$$10 \times 80 = 800$$

$$20 \times 70 = 1400$$

$$\frac{2200}{}$$

$$2200 \div 30 = 73.\dot{3}\%$$

$$73.\dot{3}\%$$

.....
(3)