

Paper 2 and Paper 3 Preparation Paper

AQA Foundation



Corbettmαths

Ensure you have: Pencil, pen, ruler, protractor, pair of compasses and eraser

You will need a calculator

Guidance

1. Read each question carefully before you begin answering it.
2. Check your answers seem right.
3. Always show your workings

Paper 2 and 3 Checklist



Question	Topic	Video number
See website	Division	98
See website	Addition	6
See website	Subtraction	304
See website	Estimation	215
See website	Time Calculations	322
See website	Indices	172, 174
See website	Adding Fractions	133
See website	Multiplying Fractions	142
See website	Negative Numbers	205 to 209
See website	Two-way Tables	319
See website	Relative Frequency	248
See website	Collecting Like Terms	9
See website	Reciprocal Graph	346
See website	Conversion Graphs	151
See website	Exact Trig Values	341
See website	Arithmetic with Decimals	90 to 94

1.

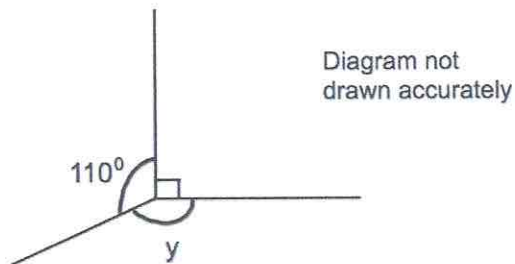

Work out the size of the angle marked y .

$$110 + 90 = 200$$

$$360 - 200 = 160$$

$$\underline{\underline{160}}^\circ$$

(1)

2.

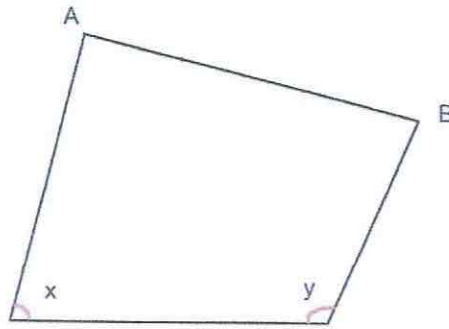

What type of angle is x ?

Acute

(1)

3.

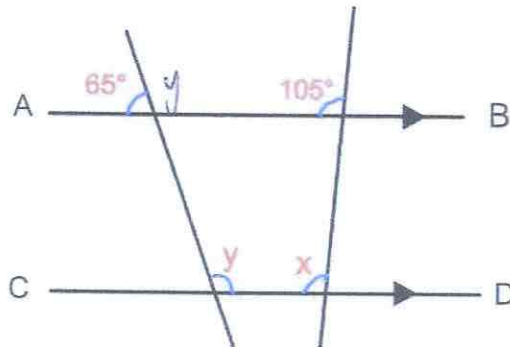

AB is parallel to CD.

(a) Work out the size of the angle marked x .

105°

Give a reason for your answer.

Corresponding angles are equal.

(2)

(b) Work out the size of the angle marked y .

$$180 - 65 = 115$$

115°

(2)

4. The diagram shows a scale drawing.

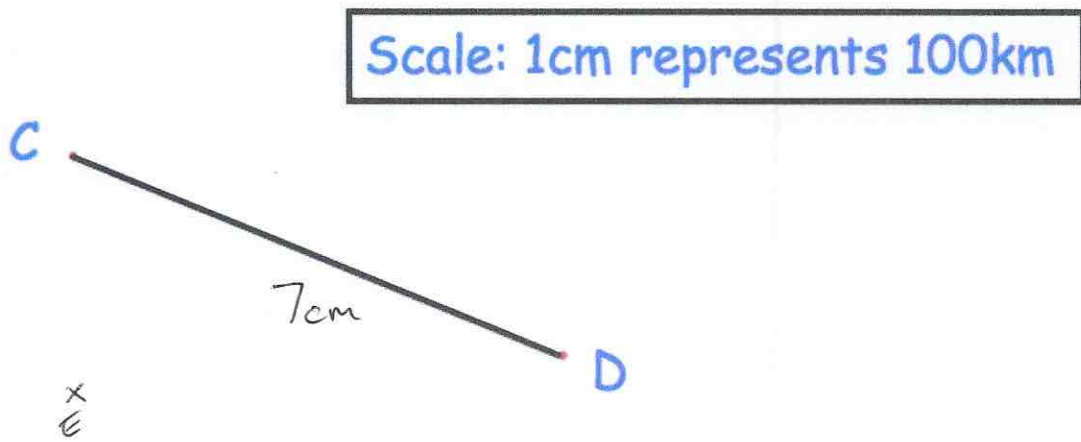

(a) Use the diagram to calculate the actual distance from C to D.

3cm
E is 300km due south of C.

.....700.....km
(2)

(c) Show E on the diagram.

(1)

5.

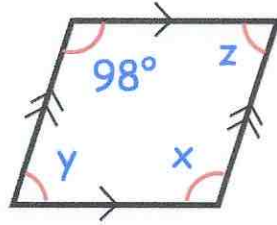

(a) Find x

$$\begin{array}{r} 98 \\ \hline \end{array} \text{ }^\circ$$

(1)

(b) Find y

$$180 - 98 = 82$$

$$\begin{array}{r} 82 \\ \hline \end{array} \text{ }^\circ$$

(1)

(c) Find z

$$\begin{array}{r} 82 \\ \hline \end{array} \text{ }^\circ$$

(1)

6. Shown is a regular hexagon and a regular octagon.

$$720 \div 6 = 120$$

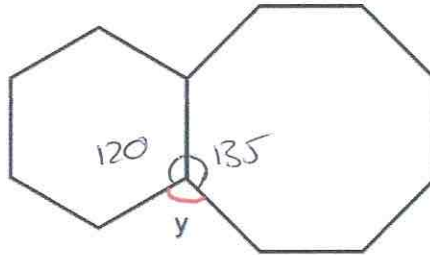

$$1080 \div 8 = 135$$

Calculate the size of angle y.

$$120 + 135 = 255$$

$$360 - 255 = 105$$

$$y = \begin{array}{r} 105 \\ \hline \end{array} \text{ }^\circ$$

(3)

7. This is a map of an island.

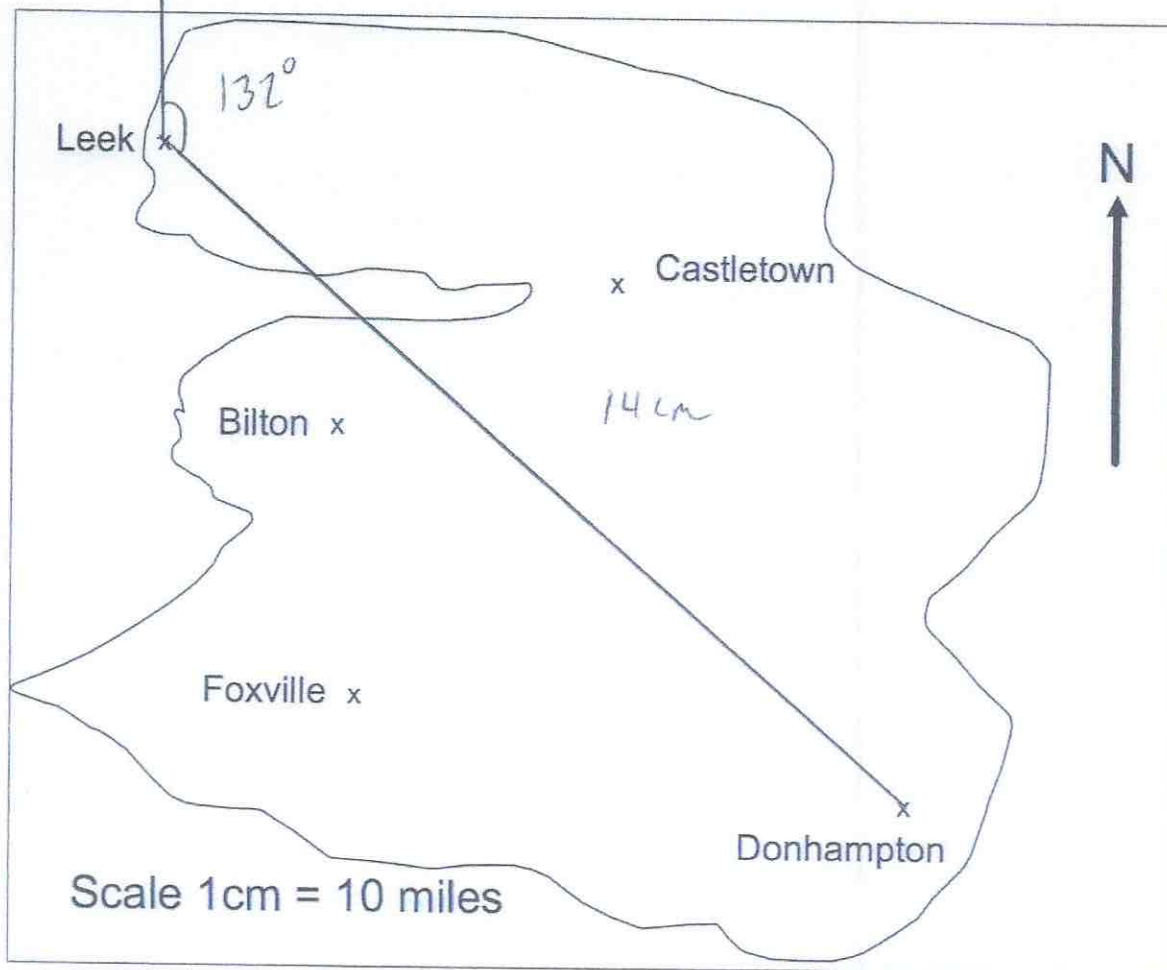

A helicopter flies in a straight line from Leek to Donhampton.

(a) How far does the helicopter fly?

$$14 \times 10$$

140
.....miles
(2)

(b) Write down the bearing of Donhampton from Leek.

132
.....°
(1)

8

Use ruler and compasses to construct the perpendicular bisector of AB.
You **must** show clearly all your construction arcs.

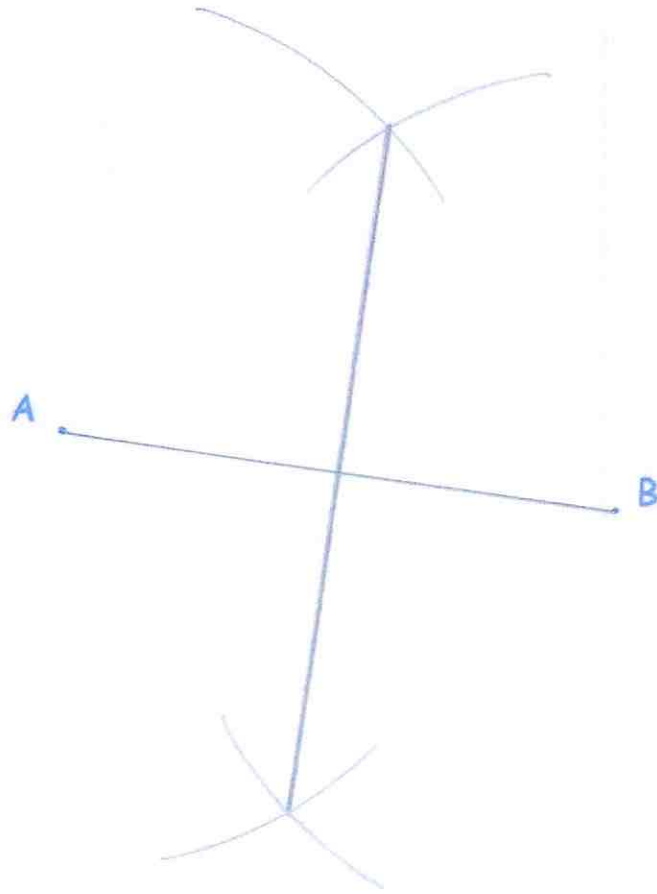

(2)

9. Shown below is a right-angled triangle.

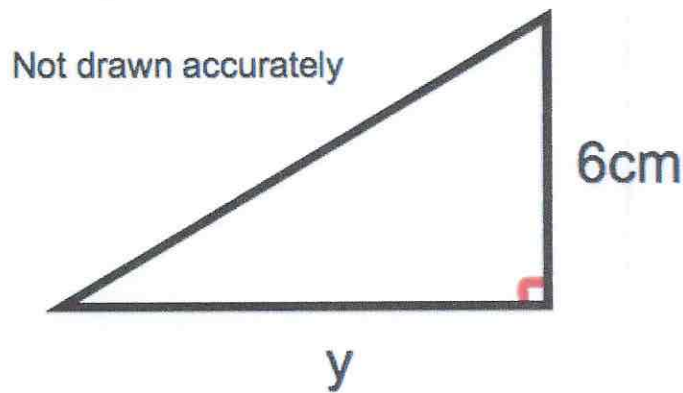

The area of the triangle is 21cm^2
Calculate y, the length of the base.

$$\begin{aligned}\frac{1}{2} \times y \times 6 &= 21 \\ y \times 6 &= 42 \\ y &= 7\end{aligned}$$

.....7.....cm
(2)

- 10.

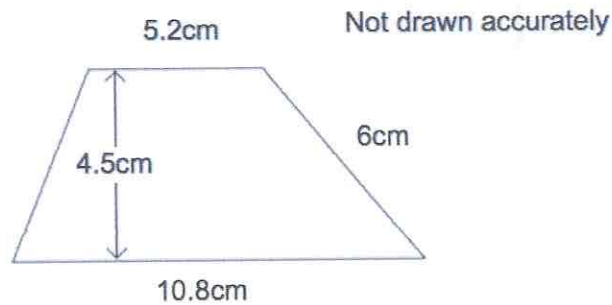

Calculate the area of the trapezium.

$$\begin{aligned}\frac{1}{2} (5.2 + 10.8) \times 4.5 \\ \frac{1}{2} (16) \times 4.5 \\ 8 \times 4.5\end{aligned}$$

.....36..... cm^2
(2)

11. The diagram shows two lighthouses.
 A boat is within than 8 miles of lighthouse A.
 The same boat is within 6 miles of lighthouse B.
 Shade the possible area in which the boat could be.

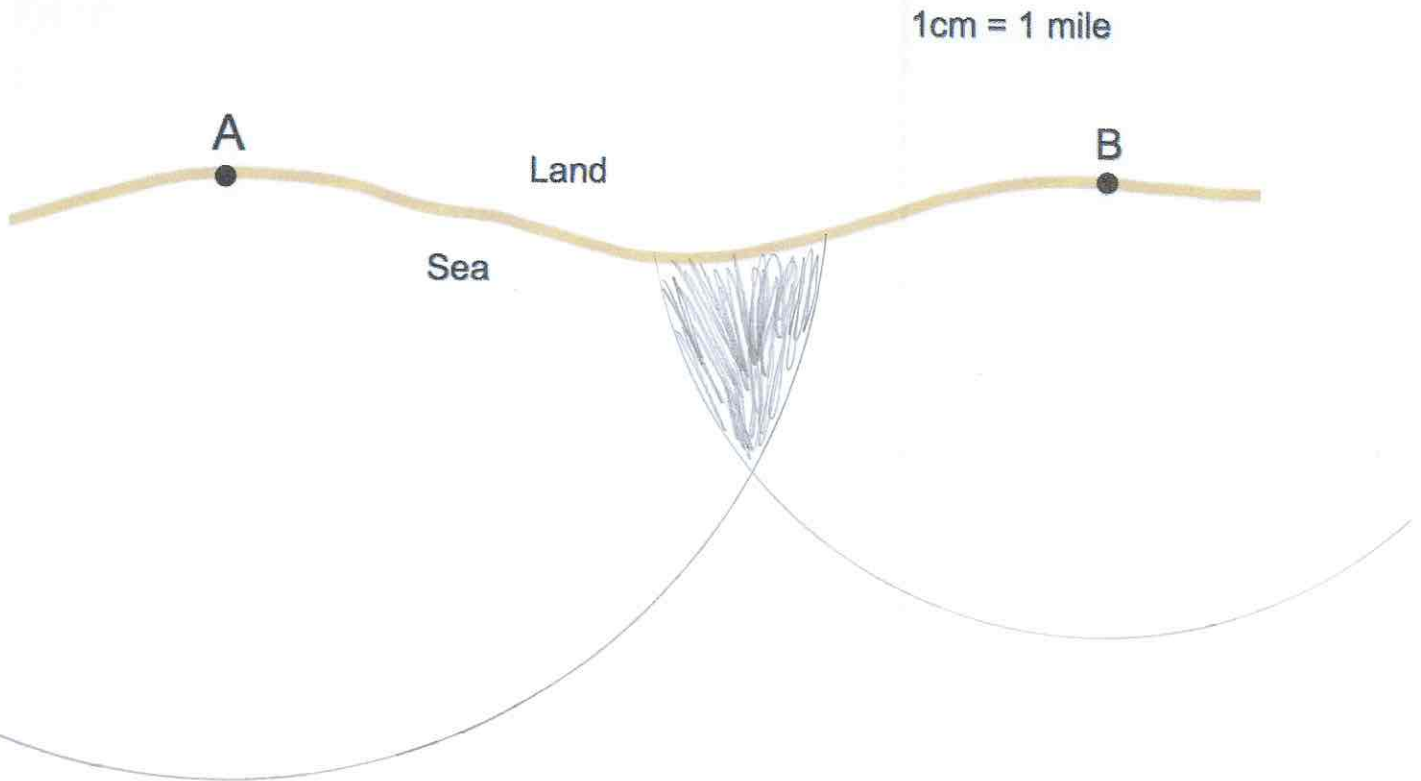

(2)

12.

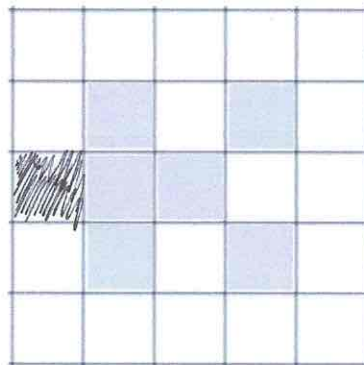

Shade one more square to make a pattern with 1 line of symmetry.

(1)

13.

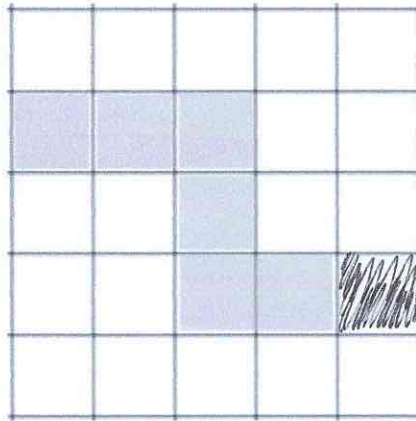

Shade one more square to make a pattern with rotational symmetry order 2.

(1)

14. Below is a solid.

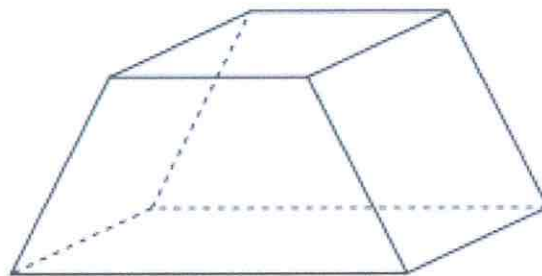

(a) Write down the number of faces

6
.....
(1)

(b) Write down the number of vertices

8
.....
(1)

15. Below are the nets of two solid shapes.

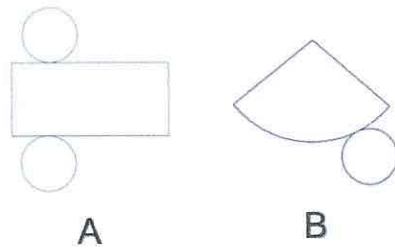

(a) Write down the shape that is made from Net A.

cylinder
(1)

(b) Write down the shape that is made from Net B.

cone
(1)

16. Shown below is a solid shape made from centimetre cubes.

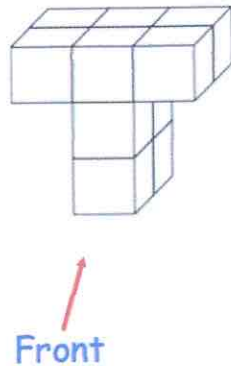

(a) On the centimetre square grid, draw the front elevation.

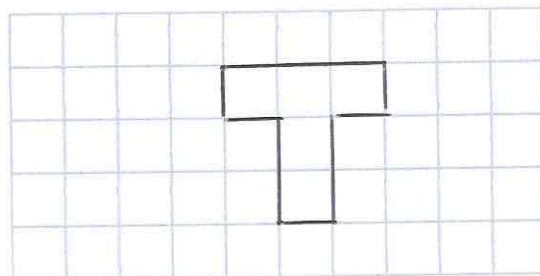

(2)

(b) On the centimetre square grid, draw the plan view.

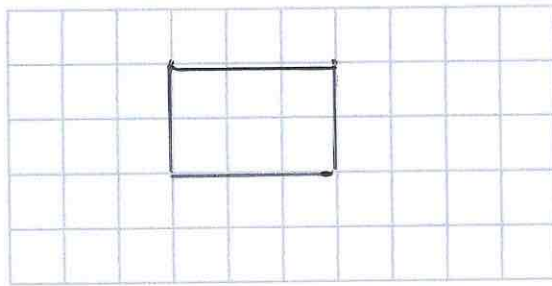

(2)

17. The distance from Leek to Milton is 310 miles.
A train travels this distance in 4 hours 15 minutes.
Calculate the average speed of the train.

$$\frac{310}{4.25} = 72.9411... \text{ mph}$$

$$\dots 72.94 \text{ mph}$$

(3)

18. Bethany drove to a family meal and then back home.
The meal was at a restaurant that is 70 kilometres from her home.
Bethany left home at 10:00 and arrived at the restaurant at 11:30.
She stayed at the family meal for 2 hours.
Bethany then drove home at a speed of 35 kilometres per hour.
Show this information on the distance-time graph.

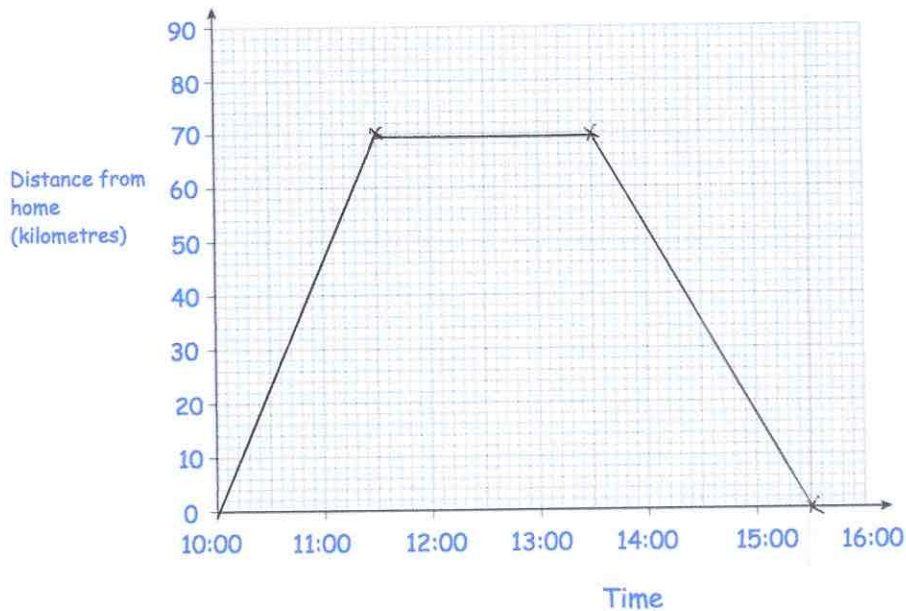

(3)

19. Iron has a density of 7.8g/cm^3 .
A solid iron statue has a mass of 877.5g .
Work out the volume of the statue.

$$V = \frac{m}{d} \qquad \frac{877.5}{7.8}$$

..... 112.5 cm^3
(2)

20. An object is placed on a table.
It exerts a force of 22 newtons on the table.

The pressure on the table is 500 newtons/ m^2

Calculate the area of the crate that is in contact with the table.
Include suitable units.



$$A = \frac{F}{P} \qquad \frac{22}{500} = 0.044\text{m}^2$$

or
 440cm^2

..... 440 cm^2
(3)

21. Here are 6 diagrams and 6 labels.
In the diagram the centre of the circle is shown with a dot.

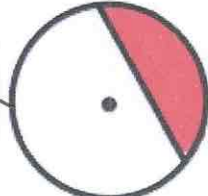
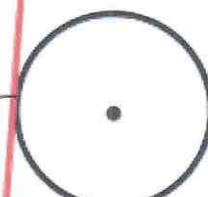
Match each diagram to its label.
One has been done for you.

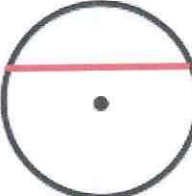
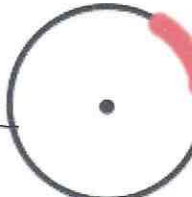
Label	Diagram
Circle and radius	
Circle and segment	
Circle and arc	
Circle and diameter	
Circle and tangent	
Circle and chord	

22.

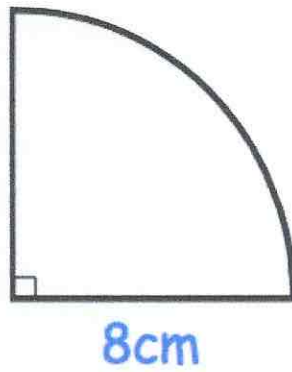

Calculate the perimeter of the sector.

$$C = \pi \times 16$$

$$= 16\pi$$

$$16\pi \div 4 = 4\pi$$

$$8 + 8 + 4\pi$$

$$\dots\dots\dots 28.6 \dots \text{cm}$$

(2)

23. A primary school has a running track.
 It has two straights of 50 metres.
 Also there are two 'bends' that are semicircles with diameter 30 metres.

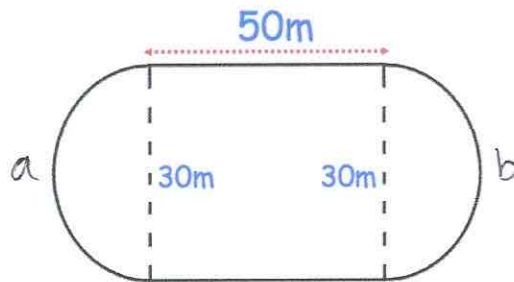

Work out the distance around the running track.

$$a + b = \text{full circle}$$

$$\pi \times 30 = 94.2477\dots \text{m}$$

$$50 + 50 + 94.247\dots$$

$$\dots\dots\dots 194.25 \dots \text{m}$$

(5)

24. The diagram shows a rectangle with a circle cut out.

Not drawn to scale

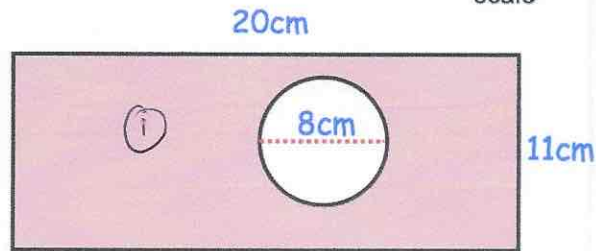

The rectangle has length 20cm and width 11cm.
The circle has diameter 8cm.

Work out the shaded area.
Give your answer correct to 2 decimal places.

$$\begin{aligned} \textcircled{1} 20 \times 11 &= 220 \text{ cm}^2 \\ \textcircled{2} \pi \times 4^2 &= 50.265\dots \\ 220 - 50.265\dots & \end{aligned}$$

$$\dots 169.73 \text{ cm}^2$$

(4)

25.

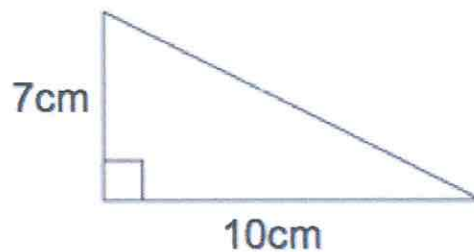

Shown is a right-angled triangle.

Work out the perimeter of the triangle

$$\begin{aligned} a^2 + b^2 &= c^2 \\ 7^2 + 10^2 &= c^2 \\ 49 + 100 &= c^2 \\ c^2 &= 149 \\ c &= 12.2065\dots \end{aligned}$$

$$7 + 10 + 12.206\dots$$

$$\dots 29.2 \text{ cm}$$

(4)

26. Triangle ABC has a right angle.
 Angle BAC is 25°
 AC = 12.5cm

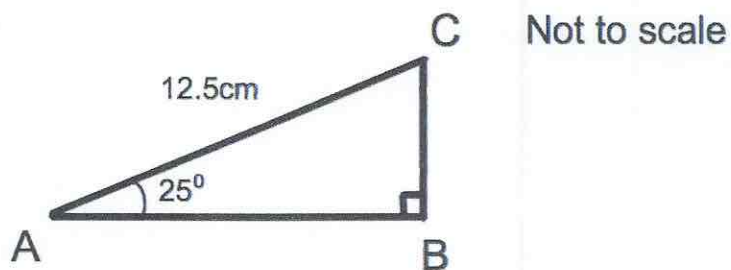

Calculate the length of AB

$$AB = \cos(25) \times 12.5$$

.....cm
 (3)

27. A store room measures 4.2m \times 3m \times 2m
 A box measures 60cm \times 50cm \times 25cm.

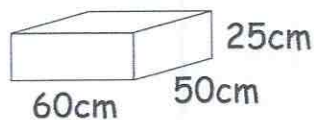
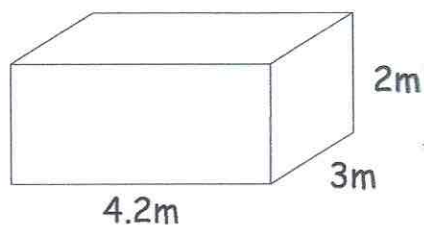

Work out the greatest number of boxes that can be stored in the store room.

$$420 \div 60 = 7$$

$$300 \div 50 = 6$$

$$200 \div 25 = 8$$

$$7 \times 6 \times 8$$

.....
 336
 (3)

28.

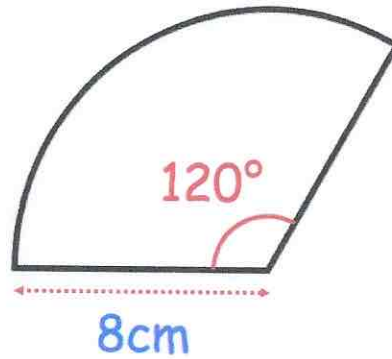

Calculate the area of the sector.

$$\frac{120}{360} \times \pi \times 8^2$$

.....67.02.....cm²
(2)

29. Write down all the prime numbers between 10 and 20.

.....11, 13, 17, 19.....
(2)

30. Below is a cylinder with radius 2cm and height 5cm.

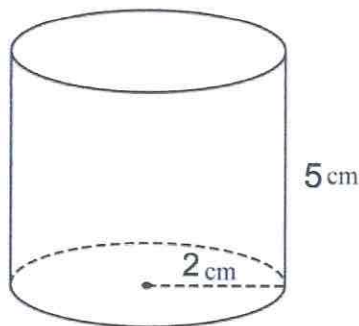

Calculate the volume of the cylinder.

$$\pi \times 2^2 \times 5$$

.....62.83.....cm³
(3)

31. From the list of numbers

3 6 8 14 16 28 41 64

(a) write down the cube numbers

..... 8 and 64
(2)

(b) write down the cube root of 27.

..... 3
(1)

32. (a) Write 50 as a product of its prime factors.

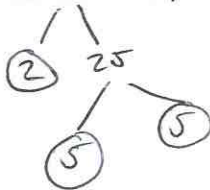

..... 2×5^2
(2)

(b) Find the Lowest Common Multiple (LCM) of 32 and 50.

$$32 = 2 \times 2 \times 2 \times 2 \times 2$$

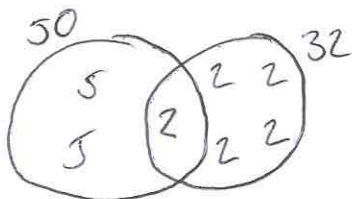

$$LCM = 2 \times 2 \times 2 \times 2 \times 2 \times 5 \times 5$$

..... 800
(2)

33. Find the HCF of 80 and 32

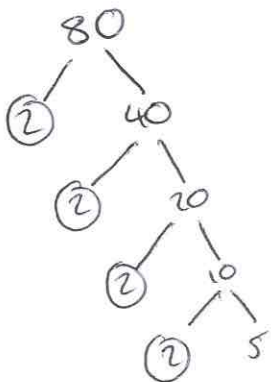

$$80 = 2^4 \times 5$$

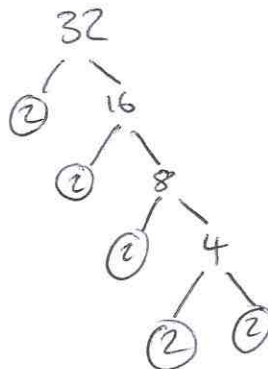

$$32 = 2^5$$

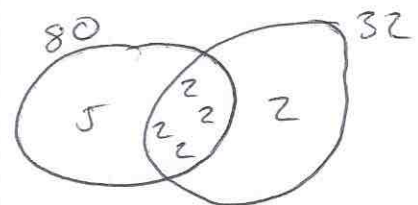

$$2 \times 2 \times 2 \times 2 = 16$$

..... 16
(3)

34.

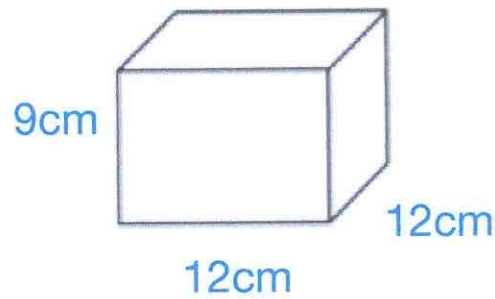

Work out the surface area of this cuboid.
State the units of your answer.

$$\begin{array}{r}
 9 \times 12 = 108 \\
 9 \times 12 = 108 \\
 12 \times 12 = 144 \\
 \hline
 216 \\
 216 \\
 288 \\
 + 720 \\
 \hline
 \end{array}$$

$$\begin{array}{r}
 \dots\dots\dots 720 \text{ cm}^2 \\
 \hline
 (3)
 \end{array}$$

35. Work out

$$10^{-2}$$

Give your answer as a decimal.

$$\frac{1}{10^2} \quad \frac{1}{100}$$

$$\begin{array}{r}
 \dots\dots\dots 0.01 \\
 \hline
 (2)
 \end{array}$$

36. A sphere has a radius of 5cm.

Calculate the surface area of the sphere.

$$4 \times \pi \times 5^2$$

$$\begin{array}{r}
 \dots\dots\dots 314.16 \text{ cm}^2 \\
 \hline
 (3)
 \end{array}$$

37. Express 42 as a percentage of 64

$$\frac{42}{64} = 0.65625$$

$$\underline{\underline{65.625\%}}$$

(2)

38. Joanne sees this special offer in a shop.

Special Offer

Laptop	£465
Printer	£109

Buy both items and receive a 4% discount

Joanne buys both items.

How much does she pay?

$$\begin{aligned} 465 + 109 &= 574 \\ 574 \div 100 &= 5.74 \\ 574 \times 4 &= 22.96 \\ 574 - 22.96 & \end{aligned}$$

$$\underline{\underline{£ 551.04}}$$

(3)

39. Sarah bought a TV for £250
Three years later she sold it for £180

Work out the percentage loss

$$\frac{70}{250} \times 100$$

$$\underline{\underline{28\%}}$$

(3)

40. Nina invested £1500 for 4 years at 2.5% per annum simple interest.

Work out the total amount of money in the account at the end of 4 years.

$$\begin{aligned}1500 \div 100 &= 15 \\15 \times 2.5 &= 37.50 \\37.50 \times 4 &= 150 \\1500 + 150 &\end{aligned}$$

£ 1650
(3)

41. Fiona leaves £1600 in the bank for four years.
It earns compound interest of 4% each year.

Calculate the total amount Fiona has in the bank at the end of the four years.

$$1600 \times 1.04^4 = \text{~~1871.77~~ } 1871.77 \dots$$

£ 1871.77
(3)

42. Lauren is given a 12% pay rise.
Her new salary is £24,080

What was Lauren's salary before the pay rise?

$$\begin{aligned}112\% &\rightarrow 24080 \\1\% &\rightarrow 215 \\100\% &\rightarrow 21500\end{aligned}$$

£ 21500
(3)

43. Chris and Molly win money in a competition.
They share the money in the ratio 2 : 3
Molly receives £240.

(a) How much money does Chris receive?

$$240 \div 3 = 80$$
$$80 \times 2 = 160$$

$$\begin{array}{r} \pounds \dots 160 \\ \hline \end{array} \quad (2)$$

(b) How much money did they win in the competition?

$$\begin{array}{r} \pounds \dots 400 \\ \hline \end{array} \quad (1)$$

-
44. Write down all the factors of 36.

$$1 \times 36$$
$$2 \times 18$$
$$3 \times 12$$
$$4 \times 9$$
$$6 \times 6$$

$$\begin{array}{r} 1, 2, 3, 4, 6, 9, 12, 18, 36 \\ \hline \end{array} \quad (2)$$

-
45. A number, n , is rounded to 1 decimal place.
The result is 1.3

Using inequalities, write down the error interval for n .

$$\begin{array}{r} 1.25 \leq n < 1.35 \\ \hline \end{array} \quad (2)$$

46. A supermarket sells Baked Beans in two different size cans.



215g

40p



395g

74p

Which size can is the best value for money?
You must show all your working.

$$215g = 40p$$
$$1g = 0.186$$

$$395g = 74p$$
$$1g = 0.187p$$

The 215g tin is better value

(4)

47. Work out

$$\sqrt[4]{100 - 2.4^3}$$

Give your answer to 3 significant figures.

$$3.04681\dots$$

$$3.05$$

(2)

48. The attendance at Frome United versus Trowbridge Rovers was 8,701.

Of this crowd, five-sevenths supported Frome United.
Calculate how many people did not support Frome United.

$$8701 \div 7 = 1243$$
$$1243 \times 2 = 2486$$

$$\begin{array}{r} 2486 \\ \hline \end{array} \quad (3)$$

49. Thomas has a recipe for making Rice Krispie cakes.
The recipe uses 120g of chocolate and 80g of Rice Krispies to make 12 cakes.

(a) How much chocolate should Thomas use to make 30 cakes?

$$120 \div 12 = 10\text{g per cake}$$
$$30 \times 10$$

$$\begin{array}{r} 300 \\ \hline \end{array} \text{g} \quad (2)$$

(b) What is 120g out of 200g expressed as a percentage?

$$\frac{120}{200} = \frac{60}{100}$$

$$\begin{array}{r} 60 \\ \hline \end{array} \% \quad (1)$$

50

The table gives information about students staying after school to play sport.

Sport	Frequency
Netball	15
Hockey	10
Rugby	26
Football	9

Angle

 90° 60° 156° 54°

60

$$360 \div 60 = 6^\circ$$

Draw an accurate pie chart to show this information.

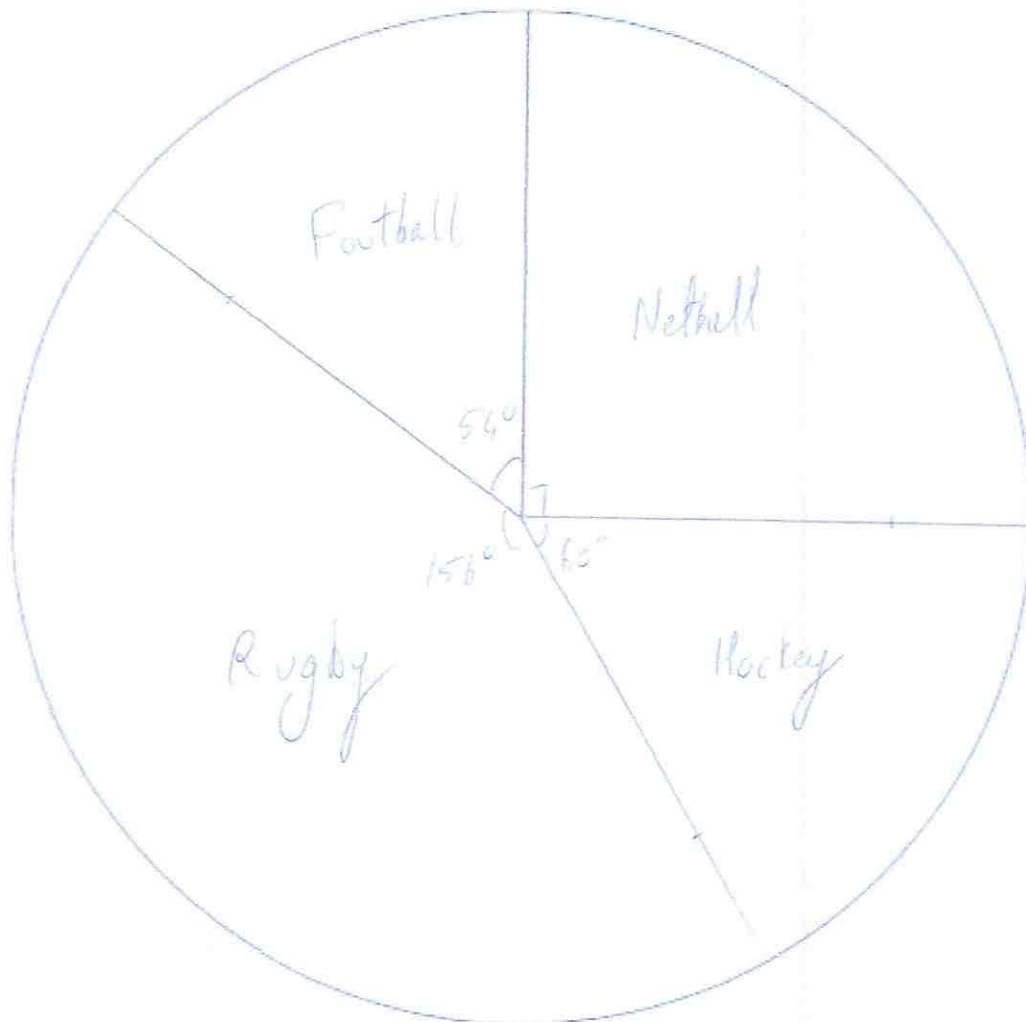

(4)

51. A rugby team can win, draw or lose a match.
The table shows the probabilities of each result.

Result	Win	Draw	Lose
Probability	0.4	0.35	

- (a) Calculate the missing probability in the table.

$$0.4 + 0.35 = 0.75$$

$$1 - 0.75$$

$$\underline{0.25}$$

(2)

Each win is worth 2 points.
Each draw is worth 1 point.
Each loss is worth 0 points.
The rugby team plays 20 games in a season.

- (b) Work out how many points the rugby team should receive in one season.

$$20 \times 0.4 = 8 \text{ wins}$$

$$20 \times 0.35 = 7 \text{ draws}$$

5 losses

$$8 \times 2 = 16$$

$$7 \times 1 = 7$$

$$\underline{23}$$

(3)

52. William is going to attend a two day summer camp at his local leisure centre. He can take part in one activity on Monday and one activity on Tuesday.

Monday	Tuesday
Golf	Ice-skating
Football	Swimming
Rugby	Dodgeball
Hockey	Basketball

List all the possible combinations of activity he can take part in.

G I F I R I H I
.....
G S F S R S H S
.....
G D F D R D H D
.....
G B F B R B H B
.....
.....
.....

(2)

53. A shop sells umbrellas.

The scatter graph shows information about the number of umbrellas sold each week and the rainfall that week, in millimetres.

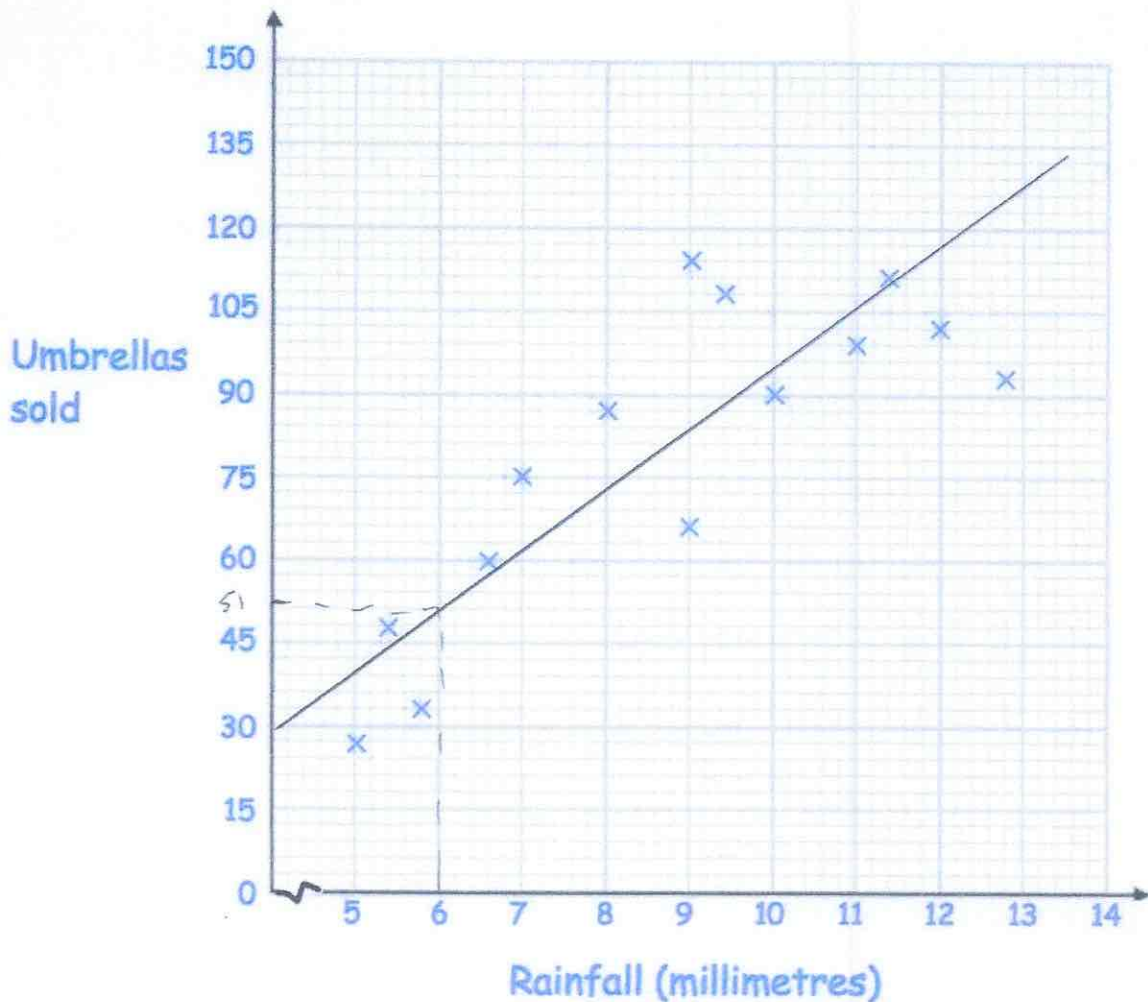

(a) Describe the relationship between the rainfall and umbrellas sold.

As the rainfall increases, so does the number of umbrellas sold.

(1)

(b) What is the greatest amount of rainfall in one week?

12.8 mm

(1)

In another week, there was 6mm of rain.

(c) Estimate the number of umbrellas sold.

51

(2)

(d) Explain why it may **not** be appropriate to use your line of best fit to estimate the number of umbrellas sold in a week with 25mm of rainfall.

Extrapolation is unreliable.
25mm is beyond the range of given data.

(1)

54. Shown below are five cards which are arranged in order from smallest to largest



The range of the cards is 4.
The median of the cards is 8.
The mean of the cards is 7.

Work out the 4 missing numbers.

$$5 \times 7 = 35$$

$$5 + 8 + 9 = 22$$

$$35 - 22 = 13$$

5 8 8 and 9

(4)

55. 5 Year 10 students and 45 Year 11 students sit a test.

The mean mark for the whole group is 70

The mean mark for the Year 11 students is 72

Work out the mean mark for the Year 10 students.

$$72 \times 45 = 3240$$

$$50 \times 70 = 3500$$

$$3500 - 3240 = 260$$

$$260 \div 5 = 52$$

52

.....
(2)

56. Timothy asked 30 people how long it takes them to get to school.

The table shows some information about his results.

Time (t minutes)	Frequency	fx
$0 < t \leq 10$ 5	2	10
$10 < t \leq 20$ 15	8	120
$20 < t \leq 30$ 25	12	300
$30 < t \leq 40$ 35	7	245
$40 < t \leq 50$ 45	1	45
	30	<u>720</u>

Work out an estimate for the mean time taken.

$$720 \div 30 = 24$$

24

.....minutes

(4)

57. A gym runs two fitness classes, spinning and circuits.

On Saturday 100 people visited the gym.

18 people attended the spinning class.

10 people attended both classes.

56 people did not attend either class.

(a) Represent this information on a Venn diagram

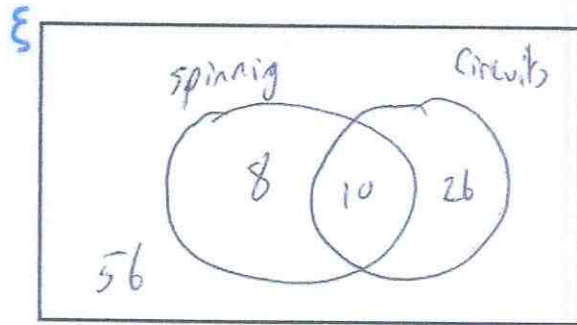

(3)

A person who attended the gym is selected at random.

Find the probability that this person

(b) attended only circuits

$$\frac{26}{100} \text{ or } \frac{13}{50}$$

(2)

(c) attended exactly one class

$$\frac{34}{100} \text{ or } \frac{17}{50}$$

(2)

58

James goes to an arcade.

He has one go on the Teddy Grabber.

He has one go on the Penny Drop.

The probability that he wins on the Teddy Grabber is 0.2.

The probability that he wins on the Penny Drop is 0.3.

(a) Complete the tree diagram.

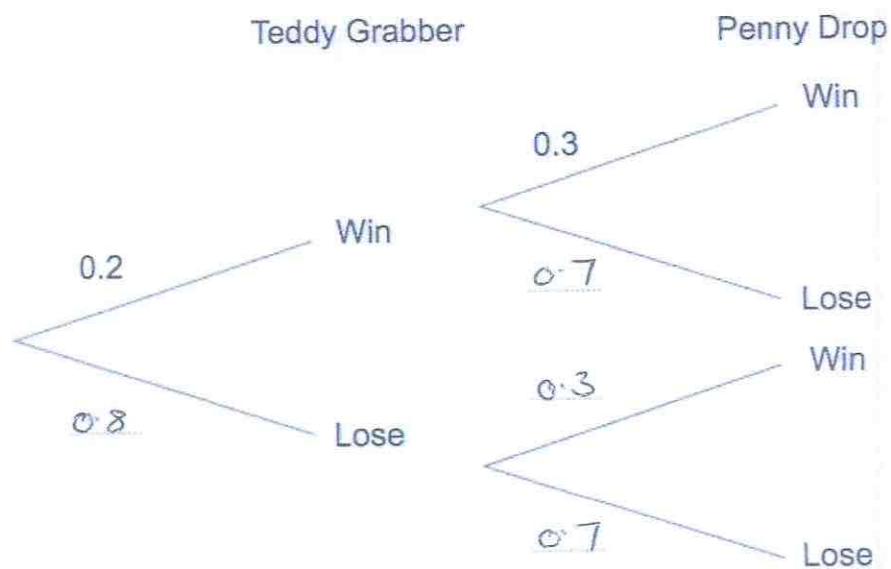

(2)

(b) Work out the probability that James wins on the Teddy Grabber and he also wins on the Penny Drop.

$$0.2 \times 0.3 = 0.06$$

$$\begin{array}{r} 0.06 \\ \hline \end{array} \quad (2)$$

59. Florence buys a car for £17100

She pays a deposit of £6750 and pays the rest in equal monthly payments.
Each monthly payment is £230

How many monthly payments does Florence make?

$$17100 - 6750 = 10350$$

$$10350 \div 230 = 45$$

45

(3)

60.

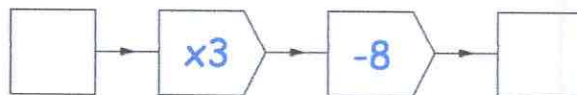

(a) Work out the output, when the input is 10.

22

(1)

(b) Work out the input, when the output is 13.

$$13 + 8 = 21$$

$$21 \div 3 = 7$$

7

(1)

(c) If the input is the same as the output, work out the input.

$$3x - 8 = x$$

$$2x = 8$$

4

(1)

61. The points A (0, 3), C (2, -3) and D (-2, -2) are shown.

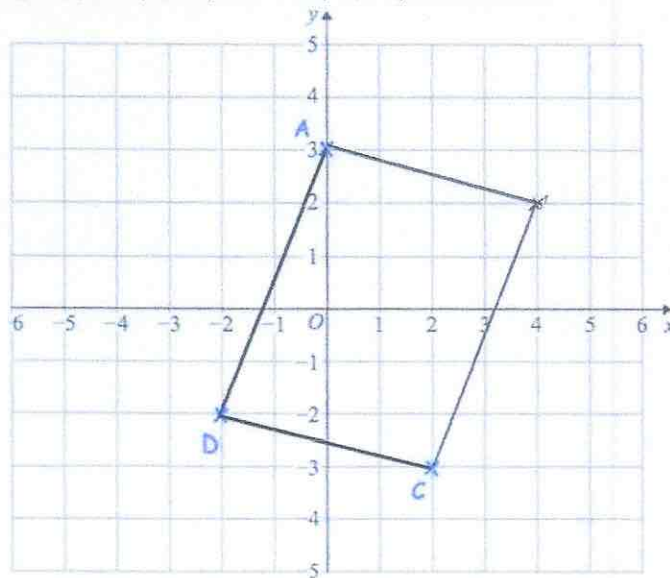

ABCD is a parallelogram.

Complete the parallelogram and write down the coordinates of B.

(4, 2)
(.....,)
(2)

62. An airplane has economy and first class seating.
 There are s seats in each row in economy.
 There are t seats in each row in first class.
 There are 8 rows in first class and 18 rows in economy.

Write down an expression, in terms of s and t , for the number of seats on the airplane.

$18s + 8t$
.....
(2)

63 The table shows the number of pages in 100 books.

Number of pages, x	Frequency
$0 < x \leq 100$	7
$100 < x \leq 200$	25
$200 < x \leq 300$	40
$300 < x \leq 400$	12
$400 < x \leq 500$	16

Write down the modal class interval.

$200 < x \leq 300$
(1)

64 A manager recorded how long each customer spent in his supermarket. The table shows his results.

Time, t (minutes)	Frequency
$0 < t \leq 10$	24
$10 < t \leq 20$	31
$20 < t \leq 30$	50
$30 < t \leq 40$	35
$40 < t \leq 50$	60

Which class interval contains the median?

$$\frac{200}{2} = 100^{\text{th}}$$

or

$$\frac{201}{2} = 100.5^{\text{th}}$$

$20 < t \leq 30$
(1)

65. The pictogram shows the amount of money raised by students in some tutor groups at a school.

Key ○ = £10

Tutor group		Raised
S	○ ○ ○ ○ ○ ○	£60
T	○ ○ ○	£30
E	○ ○ ○ ○ □	£45
P	○ ○ ○ □	£35

- (a) Complete the raised column. (2)
- (b) Complete the pictogram for tutor group E. (2)
- (c) How much money was raised altogether?

$$60 + 30 + 45 + 35$$

£.....170.....
(1)

66. Work out the n th term for this sequence

8 17 26 35 44
 a_n 9 18 27

..... a_{n-1}
(2)

67. Expand and simplify $(w - 3)(w - 8)$

$$\underline{w^2 - 11w + 24}$$

(2)

68. Factorise

$$15y + 20$$

$$\underline{5(3y + 4)}$$

(2)

69. (a) Factorise $x^2 + 2x - 24$

$$\underline{(x + 6)(x - 4)}$$

(2)

(b) Factorise $x^2 - 25$

$$\underline{(x + 5)(x - 5)}$$

(1)

70. Solve $4y + 1 = 6y + 26$

$$\begin{array}{r} -4y \quad -4y \\ 1 = 2y + 26 \\ -26 \quad -26 \\ -25 = 2y \\ \div 2 \quad \div 2 \end{array}$$

$$y = \underline{-12.5}$$

(2)

71. 140 students sign up for a college course.
 At the end of the course, each student has two attempts to pass a test.
 If a student passes either attempt, they are awarded a certificate

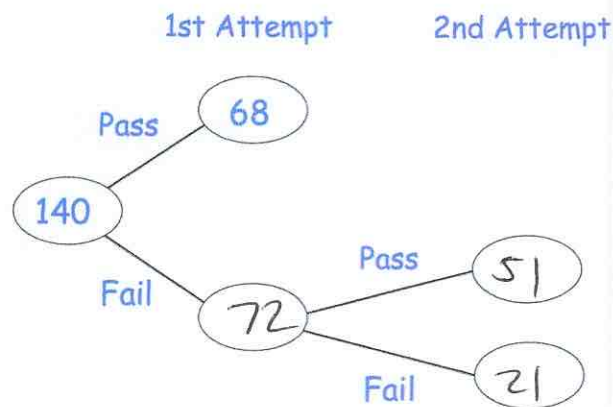

85% of the students receive a certificate.

Work out how many students passed the test in their 2nd attempt.

$$85\% \text{ of } 140 = 119$$

$$119 - 68 = 51$$

(3)

72. Solve the inequality $5x + 11 \geq 2$

$$-11 \quad -11$$

$$5x \geq -9$$

$$x \geq -1.8$$

$$\frac{x \geq -1.8}{(2)}$$

73 On the grid, draw $x + 2y = 6$ for values of x from -2 to 2 .

x	-2	-1	0	1	2
y	4	3.5	3	2.5	2

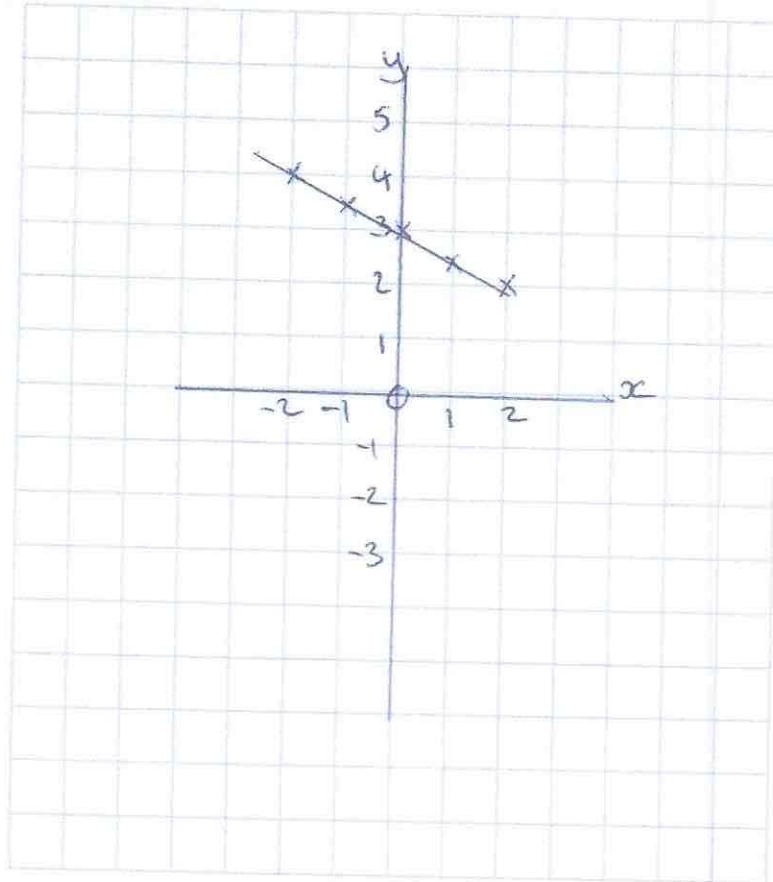

(4)

74. A straight line L is shown on the grid.

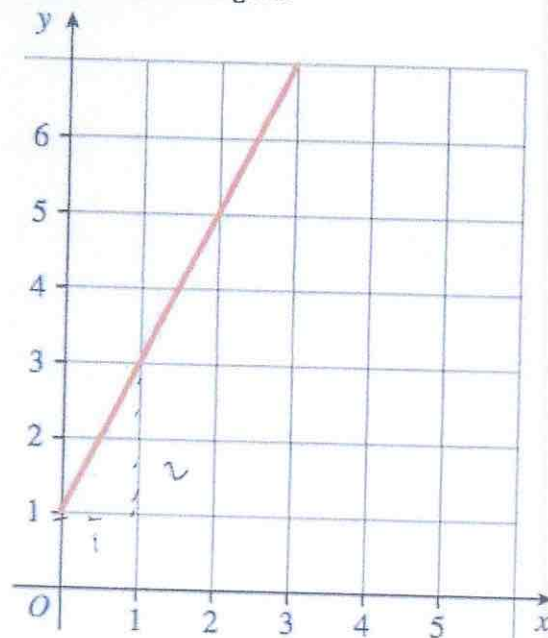

Work out the equation of line L

$$y = 2x + 1$$

.....
(3)

75. A is the point with coordinates (1, 4).
B is the point with coordinates (7, 22).

Find the gradient of AB.

$$\frac{18}{6} = 3$$

$$3$$

.....
(2)

76. The graph below shows the depth of water in a container.

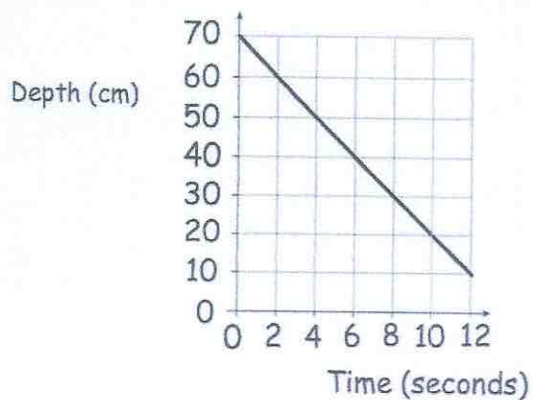

(a) Write down the gradient of the line

$$\frac{-50}{10} = -5$$

$$\frac{-5}{\dots}$$

(1)

(b) What does the gradient of the line represent?

The change in depth of water each second.

(1)

77.

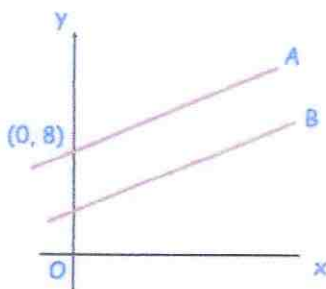

The lines A and B are parallel.

The line A passes through the point (0, 8)

The line B has equation $y = 3x + 4$

Write down the equation of line A

$$y = 3x + 8$$

(2)

78. Make w the subject of the formula

$$y = 3w - a$$

$$y + a = 3w$$

$$w = \frac{y+a}{3}$$

$$w = \frac{y+a}{3} \dots\dots\dots (2)$$

79. Solve the simultaneous equations

$$2x + 4y = 26$$

$$3x - y = 4$$

Do not use trial and improvement

$$\begin{array}{r} 2x + 4y = 26 \\ 12x - 4y = 16 \\ \hline 14x = 42 \end{array}$$

$$x = 3$$

$$9 - y = 4$$

$$y = 5$$

$$x = 3 \dots\dots\dots y = 5 \dots\dots\dots (3)$$

80. (a) Complete the table of values for $y = x^2 - 3x$

x	-2	-1	0	1	2	3	4
y	10	4	0	-2	-2	0	4

(2)

(b) On the grid, draw the graph of $y = x^2 - 3x$ for the values of x from -2 to 4.

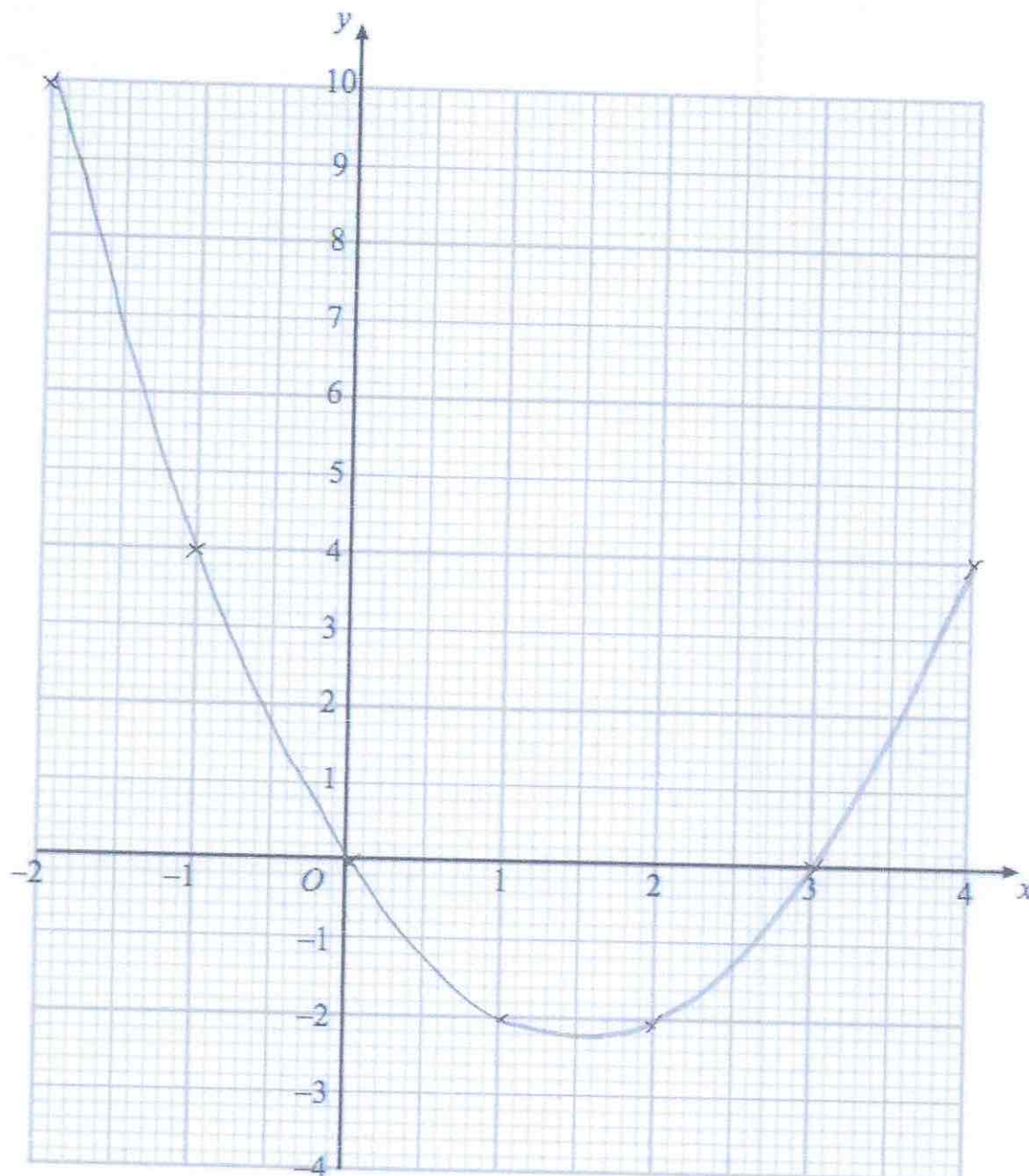

(2)

81.

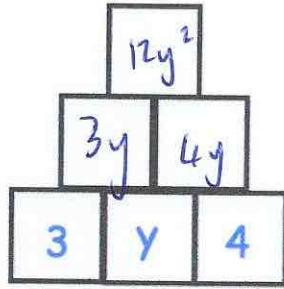

To find the contents of each empty box, multiply the two terms directly beneath it.

Complete the multiplication pyramid.

(3)

82. A glass contains water.

Below are four estimates of the amount of water in the glass.
Circle the most appropriate estimate.

25ml

25L

250ml

2.5L

(1)

83.

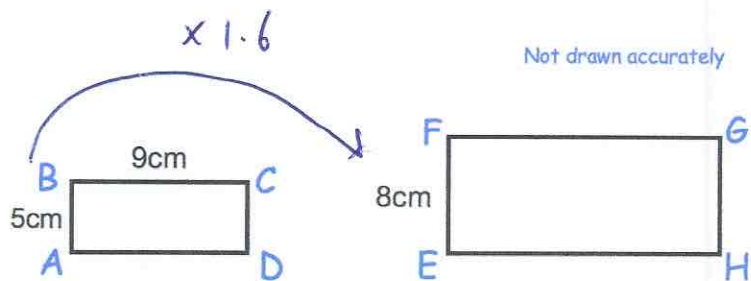

Rectangles $ABCD$ and $EFGH$ are similar.

$$AB = 5\text{cm}$$

$$BC = 9\text{cm}$$

$$EF = 8\text{cm}$$

$$9 \times 1.6 = 14.4$$

Work out the length of FG .

..... 14.4cm
(2)

84. Shown below are six triangles that are not drawn accurately.

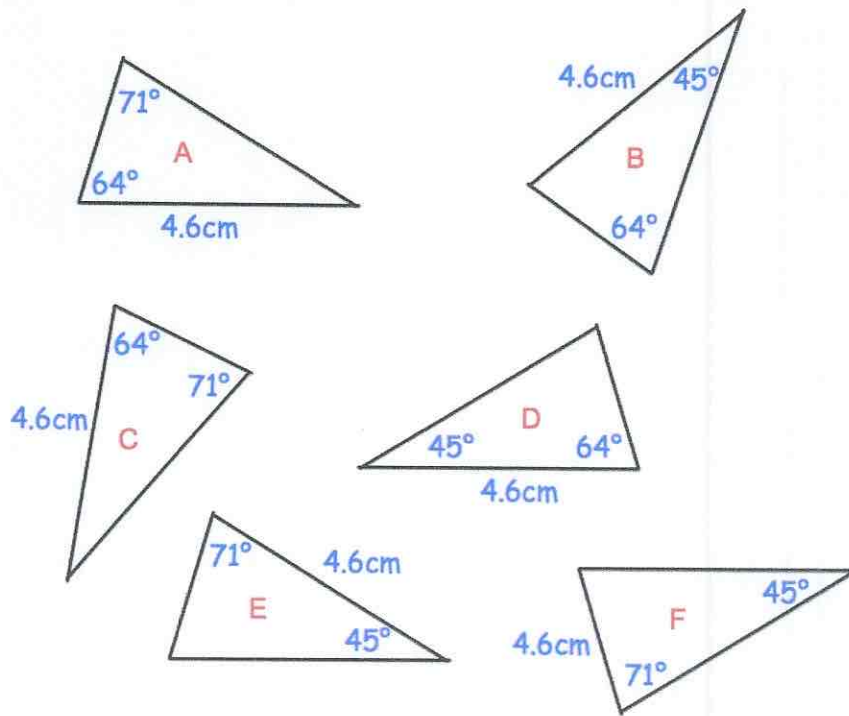

Which two triangles are congruent to triangle A?

D and C
 and
 (2)

85. Holly works out the answer to $135.66 + 193.88$ on a calculator.

Her answer is 329.54

(a) Round her answer to the nearest 10.

330

 (1)

(b) Round her answer to the nearest 100.

300

 (1)

(c) Round her answer to one decimal place.

329.5

 (1)

86. Write these numbers in order of size.
Start with the smallest number.

0.92 0.901 0.99 0.099 0.909

0.099, 0.901, 0.909, 0.92, 0.99

(1)

87. Mr Holland has 2500kg of rice.

- (a) Write 2500 kg in grams.
Give your answer in standard form.

2500000

2.5×10^6

.....g
(2)

- (b) One grain of rice weighs 0.03g
Write the weight of one grain of rice in standard form.

3×10^{-2}

.....g
(1)

- (c) How many grains of rice are there in 2500kg of rice?
Give your answer in standard form.

$(2.5 \times 10^6) \div (3 \times 10^{-2})$

8.3×10^7

.....
(2)

88. Here are four digits.

9 4 7 5

(a) Use two of these digits to make the largest possible two-digit number.

97
.....
(1)

(b) Use all four of these digits to make the four-digit number closest to 5000.

4975
.....
(1)

89. It takes 6 hours for 20 workers to seed 40 acres.

How long would it take 10 workers to seed 90 acres?

$$6 \times 20 = 120$$

$$120 \div 40 = 3$$

$$90 \times 3 = 270$$

$$270 \div 10$$

27
.....
(3)

90

Sophie asks 20 of her friends to choose their favourite sport.

Their replies are

Rugby Football Rugby Hockey Cricket
Football Football Rugby Hockey Football
Rugby Cricket Hockey Football Football
Football Rugby Football Football Rugby

Complete the tally and the frequency columns in the table below.

Sport	Tally	Frequency
Rugby	1	6
Football		9
Hockey		3
Cricket		2

(2)

91¹⁰⁶

Below is a line graph that shows the population of a village.

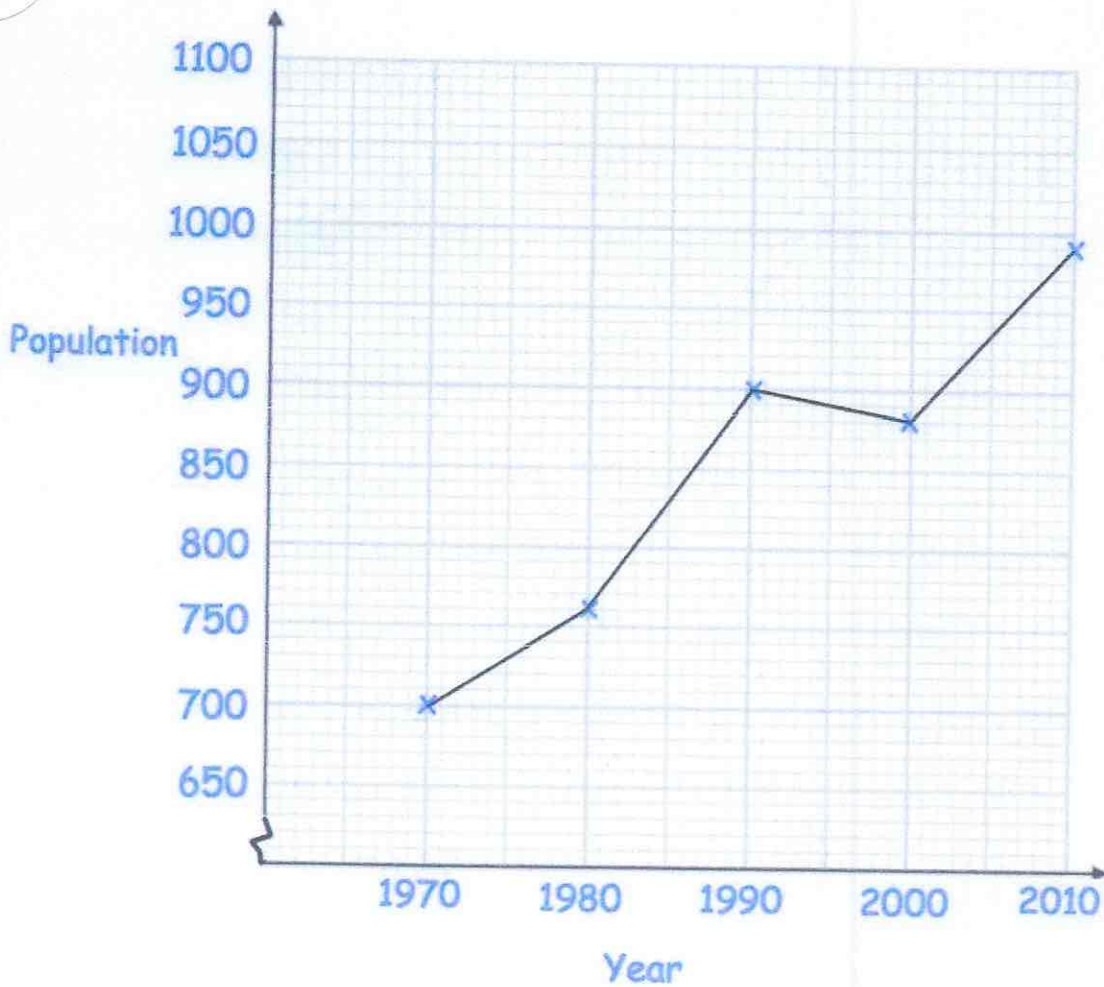

(a) What was the population in 1980?

760

(1)

(b) In which year was the population 700?

1970

(1)

The population increased by 120 by 2020.

(c) Work out the population in 2020.

$990 + 120$

1110

(2)

92

Circle the geometric progression.

11, 9, 7, 5 ...

1, 4, 9, 16 ...

11, 21, 31, 41 ...

1, 4, 16, 64 ...

(1)

93

(a) Complete the table of values for $y = x^3 - 2x + 3$

x	-2	-1	0	1	2
y	-1	4	3	2	7

(2)

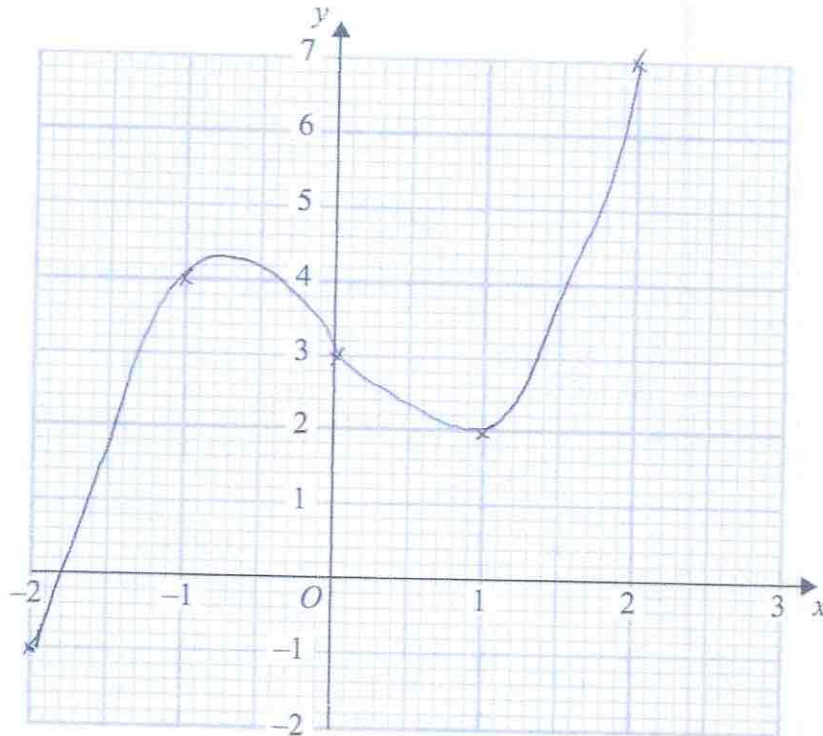
(b) On the grid, draw the graph of $y = x^3 - 2x + 3$ for the values of x $-2 \leq x \leq 2$ 

(2)

94.

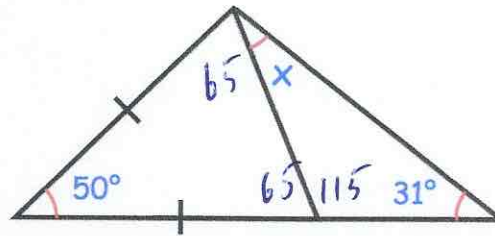

$$180 - 50 = 130$$

$$130 \div 2 = 65$$

$$180 - 65 = 115$$

$$180 - (115 + 31) = 34$$

Find the size of the angle marked x.

$$\begin{array}{r} 34 \\ \hline \end{array} \text{ }^\circ$$

(3)

95. The perimeter of a parallelogram is 17cm.
The length of each long side is 5cm.

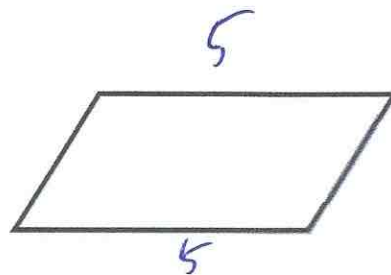

Work out the length of each short side.

$$5 + 5 = 10$$

$$17 - 10 = 7$$

$$7 \div 2 = 3.5$$

$$\begin{array}{r} 3.5 \\ \hline \end{array} \text{cm}$$

(2)

96. The mass of a 2p coin is 7g.

Find the mass of £6 worth of 2p coins.
Give your answer in kilograms.

$$600 \div 2 = 300 \text{ coins}$$

$$300 \times 7 = 2100 \text{ g}$$

$$\begin{array}{r} 2.1 \\ \hline \end{array} \text{kilograms}$$

(4)

97

Here is part of a timetable for a bus.

Southville	09 18	10 38	12 05
Leek	09 28	10 48	-----
Milton	09 41	11 01	-----
Newtown	09 49	11 09	-----
Red Island	09 55	11 15	12 36
Sandville	10 13	11 33	-----
Bakerstown	10 31	11 51	13 00

A bus leaves Southville at 10 38

(a) At what time should the bus arrive at Newtown?

11:09
.....
(1)

(b) How long will the journey take?

31
.....minutes
(1)

James arrives at the Milton bus stop at 09 29.
He waits for the next bus to Red Island.

(c) (i) How many minutes should he wait?

12
.....minutes
(1)

(ii) At what time should James arrive at Red Island?

09:55
.....
(1)

Sally wants to travel from Southville to Bakerstown.
The 12 05 is an 'express' bus.

(d) How many minutes shorter is the journey if she takes the 'express bus'?

18
.....minutes
(2)

98. The distance chart below shows the distance, in miles, between some towns and cities.

Cambridge			
54	Ipswich		
64	45	Norwich	
43	82	78	Peterborough

(a) Write down the distance between Ipswich and Peterborough.

82
..... miles
(1)

(b) Write down the distance between Norwich and Cambridge.

64
..... miles
(1)

(c) Write down the names of the places that are 78 miles apart

Norwich and Peterborough
.....
(1)

99.

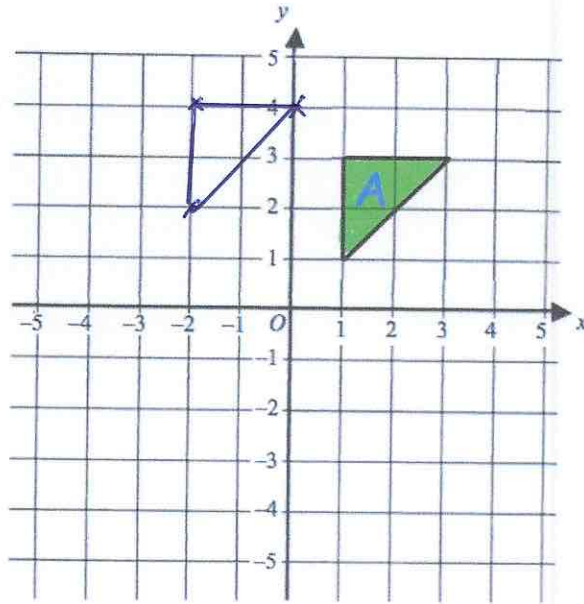

$$\begin{pmatrix} -3 \\ 1 \end{pmatrix}$$

Translate triangle A by the vector

(2)

100.

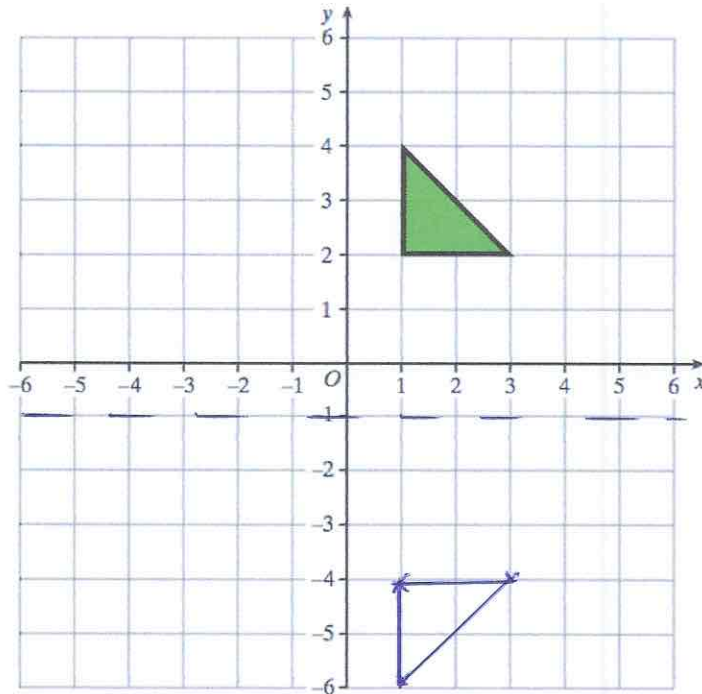

Reflect the triangle in the line $y = -1$
Label the new triangle B.

(2)

101

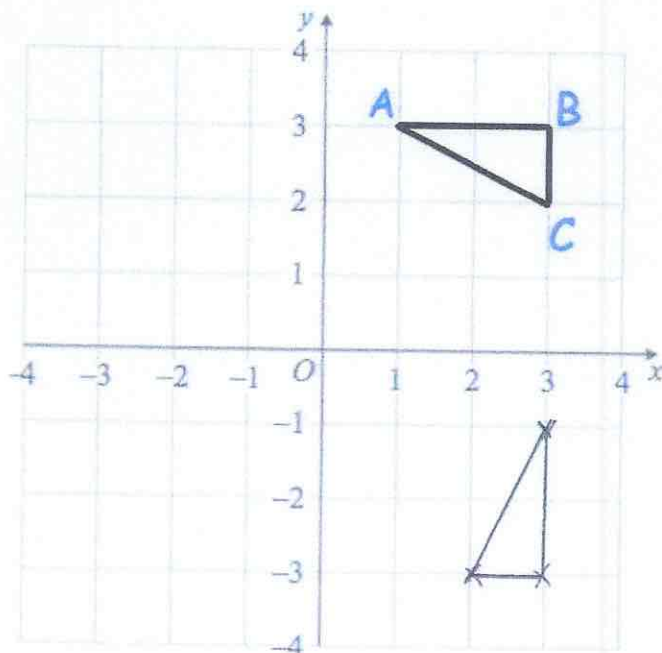

Rotate triangle ABC 90° clockwise about centre (0, 0)

(3)

102

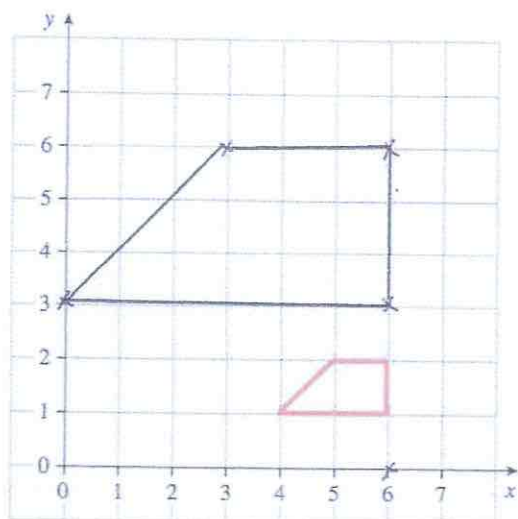

Enlarge the trapezium by scale factor 3, centre (6, 0).

(2)

103. Megan says "when you square root a number, the answer is always smaller."

Show she is wrong.

$$\sqrt{1} = 1$$
$$\sqrt{0} = 0$$

(2)

104. Complete the table.

Fraction	Decimal	Percentage
$\frac{17}{20}$	0.85	85%
$\frac{3}{25}$	0.12	12%
$\frac{23}{25}$	0.92	92%

(4)

105. Sophie went to Spain.
She changed £225 into euros (€).

The exchange rate was £1 = €1.62

(a) Change £225 into euros (€).

$$225 \times 1.62$$

$$\text{€} \underline{364.50}$$

(2)

On her return to England, Sophie changed €66 into pounds (£)

The new exchange rate was £1 = €1.50

(b) Change €66 into pounds (£).

$$66 \div 1.5$$

$$\text{£} \underline{44}$$

(2)

106

Miss Jackson asked the 32 students in her tutor group which language they study.

Each student studies one language only.

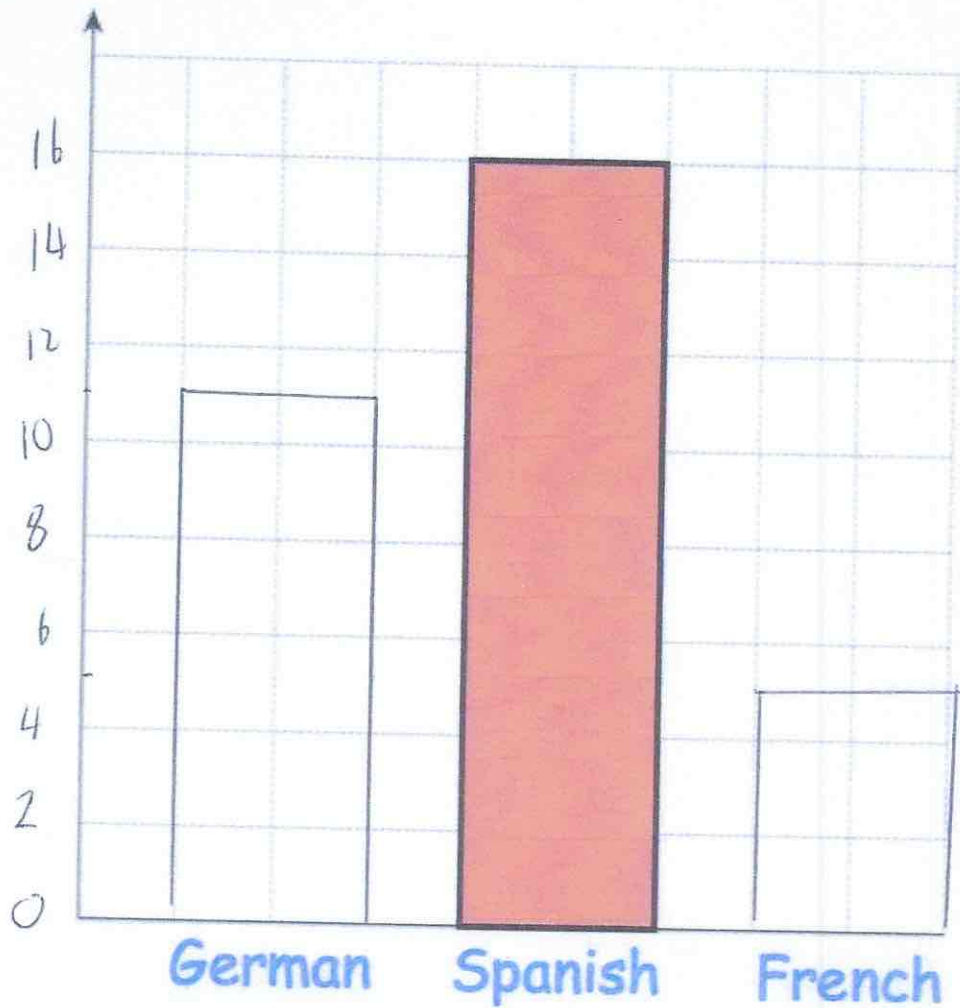

Half of the students in the tutor group study Spanish.
Six more students study German than French.

Complete the bar chart.

107

Name	Price (£)	Mass (kg)	Thickness (cm)	Battery (minutes)
Epic	£799	1.23	1.89	690
Bell	£1249	1.2	1.52	650
Lemon	£1599	1.37	1.49	720
HB	£799	1.28	1.7	740
Lazer	£1049	1.35	1.66	660

(a) Which laptop is the thickest?

Epic

(1)

(b) How much longer does the HB battery last than the Bell battery?

$$740 - 650$$

90 mins

(1)

108

480 students attend a school.

A teacher asks 50 students which colour they would like the new school blazer to be.

The table shows the results.

Colour	Number of students
Black	20
Navy	15
Green	9
Maroon	6

Estimate how many of the 480 students would like a black blazer.

$$\frac{20}{50} \times 480 = 192$$

192

(2)

109. (a) Simplify

$$m^9 \times m^2$$

$$\frac{m^{11}}{\dots\dots\dots} \quad (1)$$

(b) Simplify

$$\frac{m^{10}}{m^2}$$

$$\frac{m^8}{\dots\dots\dots} \quad (1)$$

(c) Simplify

$$(m^3)^6$$

$$\frac{m^{18}}{\dots\dots\dots} \quad (1)$$

110. Here is a pattern of dots



(a) Continue the pattern to show Pattern 4



(2)

(b) How many dots will there be in Pattern 6?

17 21

$$\frac{21}{\dots\dots\dots} \quad (1)$$

111.

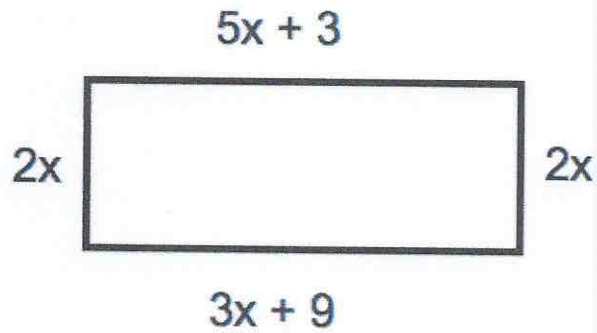

The diagram shows a rectangle. The sides are measured in centimetres.

(a) Explain why $5x + 3 = 3x + 9$

The opposite sides of a rectangle have equal lengths

(1)

(b) Solve $5x + 3 = 3x + 9$

$$2x + 3 = 9$$

$$2x = 6$$

$$x = 3$$

$$x = 3 \text{ cm}$$

(2)

(c) Calculate the perimeter of the rectangle.

$$48 \text{ cm}$$

(2)

112. OCPL is formed from nine congruent parallelogram

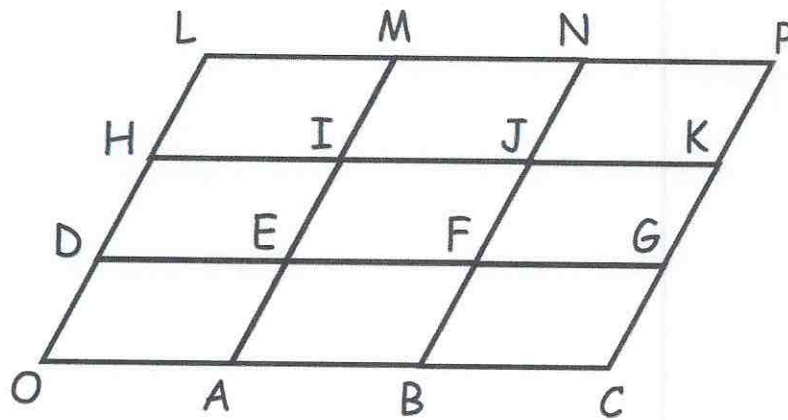

$$\vec{OA} = \mathbf{a} \quad \vec{OD} = \mathbf{b}$$

Write the vector \vec{OG} in terms of \mathbf{a} and \mathbf{b} .

$$3\mathbf{a} + \mathbf{b}$$

(1)

113. Given

$$a = 11 - 3^2$$

2

$$b = \frac{60}{2+3}$$

12

$$c = 18 - 3 \times 2 + 1$$

13

Work out the value of $a + b + c$

$$2 + 12 + 13 = 27$$

$$27$$

(4)

114. Work out

$$\frac{5}{13} \div \frac{2}{3}$$

$$\frac{5}{13} \times \frac{3}{2} = \frac{15}{26}$$

$$\frac{15}{26}$$

(1)

115. Write down the reciprocal of 0.35

$$0.35 = \frac{7}{20}$$

$$\frac{7}{20} \rightarrow \frac{20}{7}$$

$$\frac{20}{7}$$

(1)