

Paper 2 and Paper 3 Preparation Paper

OCR Foundation



Corbettmαths

Ensure you have: Pencil, pen, ruler, protractor, pair of compasses and eraser

You will need a calculator

Guidance

1. Read each question carefully before you begin answering it.
2. Check your answers seem right.
3. Always show your workings

Paper 2 and 3 Checklist



| Question | Topic | Video number |
|---|------------------------------|---------------|
| 117 | Forming Equations | 114,115 |
| 118 | Rotations | 275 |
| 119 | Standard Form | 300, 302, 303 |
| 120 | Proportion | 255a, 254 |
| 121 | Frequency Trees | 376 |
| 122 | Pie Charts | 163,164 |
| 123 | Samples | 281a |
| 124 | Multiplying & Dividing Terms | 18,11 |
| 125 | Expanding Brackets | 13 |
| 126 | Factorising | 117 |
| Seen Topics (remember they may still appear, so they may be worthwhile recapping) | | |
| See website | Bar Charts | 147,148 |
| See website | Similar Shapes (sides) | 292 |
| See website | Vectors | 353a, 353 |
| See website | Use of a Calculator | 352 |
| See website | Estimated Mean | 55 |
| See website | Tree Diagrams | 252 |
| See website | Function Machines | 386 |
| See website | Equation of a Line | 191 |
| See website | Expanding 2 Brackets | 14 |

1.

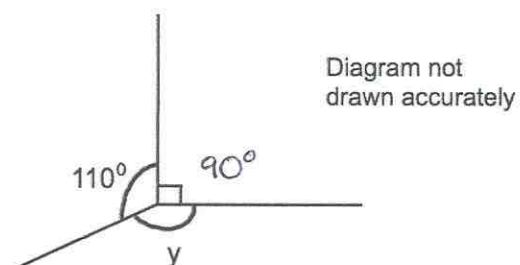

Work out the size of the angle marked y .

$$110 + 90 = 200$$

$$360 - 200$$

$$\dots\dots\dots 160 \dots\dots\dots^\circ$$

(1)

2.

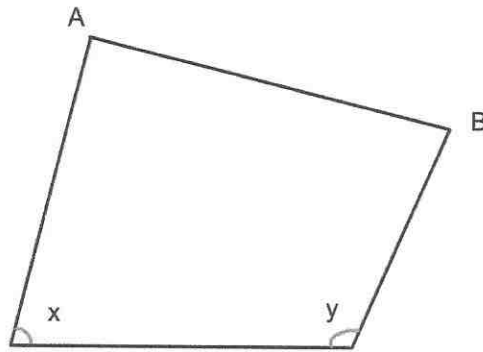

What type of angle is x ?

acute
(1)

3.

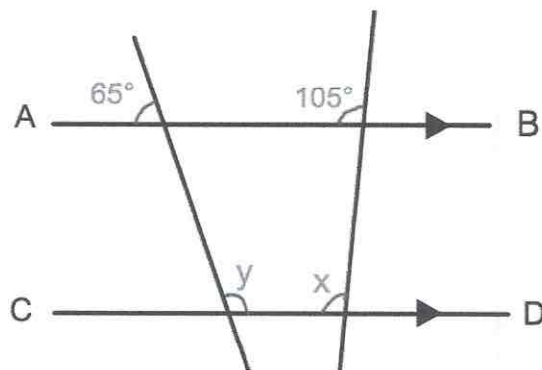

AB is parallel to CD.

(a) Work out the size of the angle marked x .

105°

Give a reason for your answer.

Corresponding angles are equal

(2)

(b) Work out the size of the angle marked y .

115°
(2)

4.

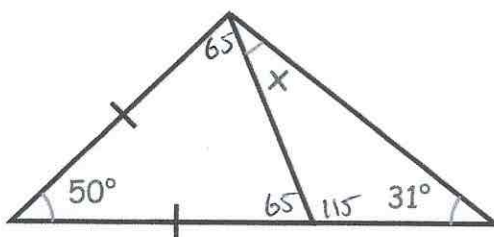

Find the size of the angle marked x.

$$180 - 50 = 130$$

$$130 \div 2 = 65^\circ$$

$$180 - 65 = 115$$

$$115 + 31 = 146^\circ$$

$$180 - 146 = 34$$

..... 34
(3)

5.

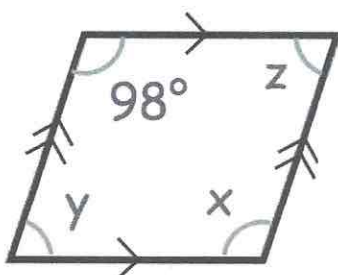

(a) Find x

..... 98
(1)

(b) Find y

..... 82
(1)

(c) Find z

..... 82
(1)

6. Shown is a regular hexagon and a regular octagon.

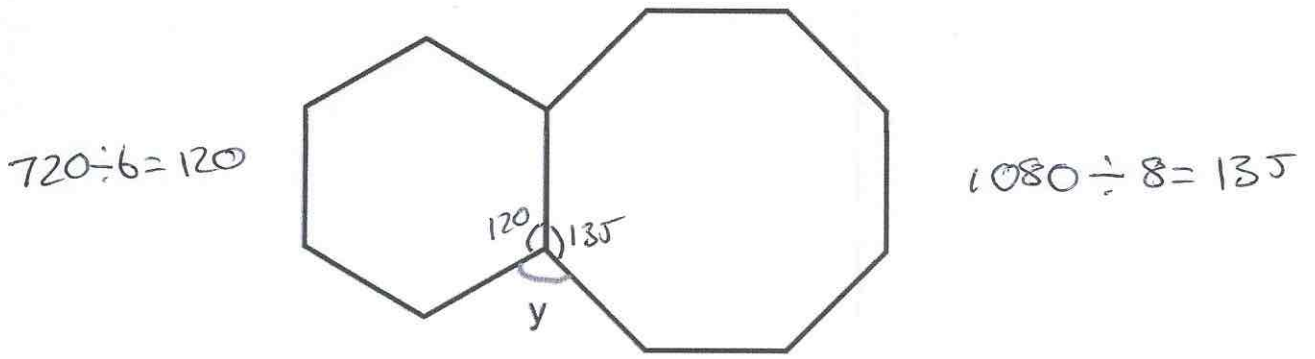

Calculate the size of angle y .

$$120 + 135 = 255$$

$$360 - 255 = 105$$

$$y = \dots\dots 105 \dots\dots^\circ$$

(3)

7. Shown below is a right-angled triangle.

Not drawn accurately

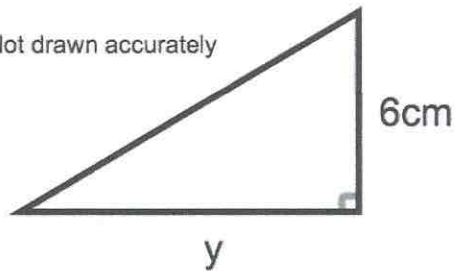

The area of the triangle is 21cm^2
Calculate y , the length of the base.

$$\frac{1}{2} \times y \times 6 = 21$$

$$y \times 6 = 42$$

$$y = 7$$

$$\dots\dots 7 \dots\dots \text{cm}$$

(2)

8.

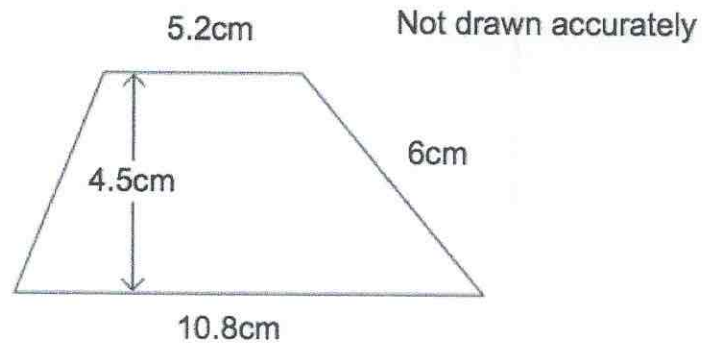

Calculate the area of the trapezium.

$$\frac{1}{2} (5.2 + 10.8) \times 4.5$$
$$\frac{1}{2} (16) \times 4.5$$

.....36.....cm²
(2)

9.

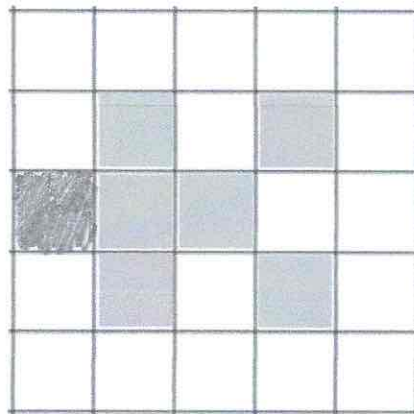

Shade one more square to make a pattern with 1 line of symmetry.

(1)

10.

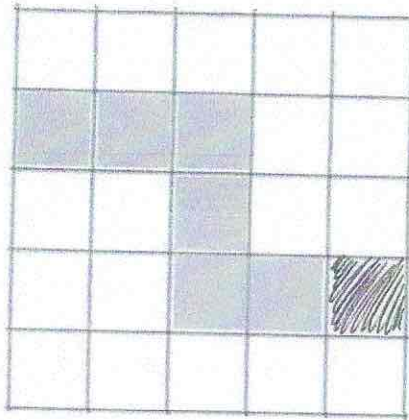

Shade one more square to make a pattern with rotational symmetry order 2.

(1)

11. Use ruler and compasses to construct the perpendicular bisector of AB.
You **must** show clearly all your construction arcs.

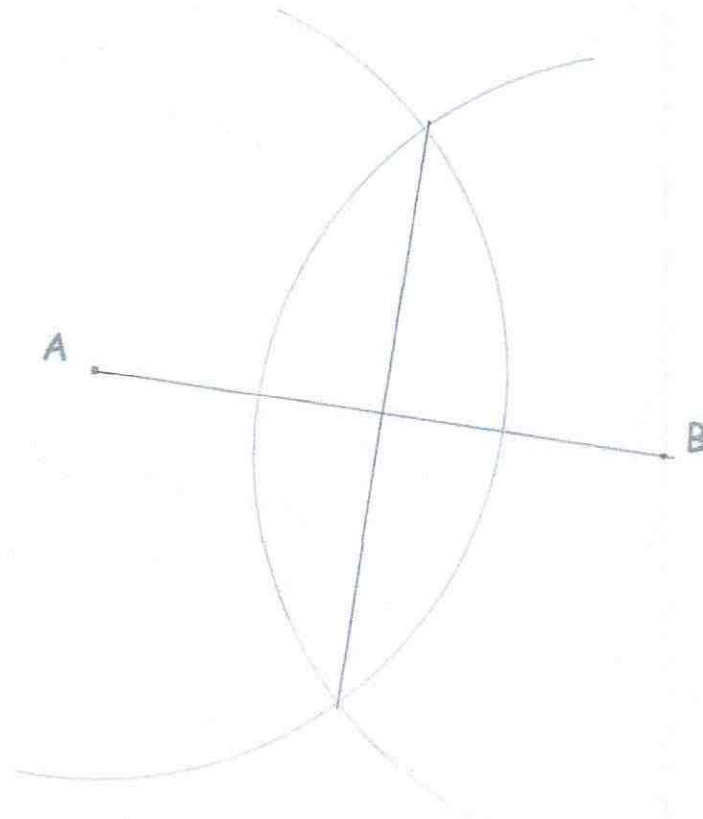

(2)

12 The diagram shows two lighthouses.

A boat is within than 8 miles of lighthouse A.
The same boat is within 6 miles of lighthouse B.

Shade the possible area in which the boat could be.

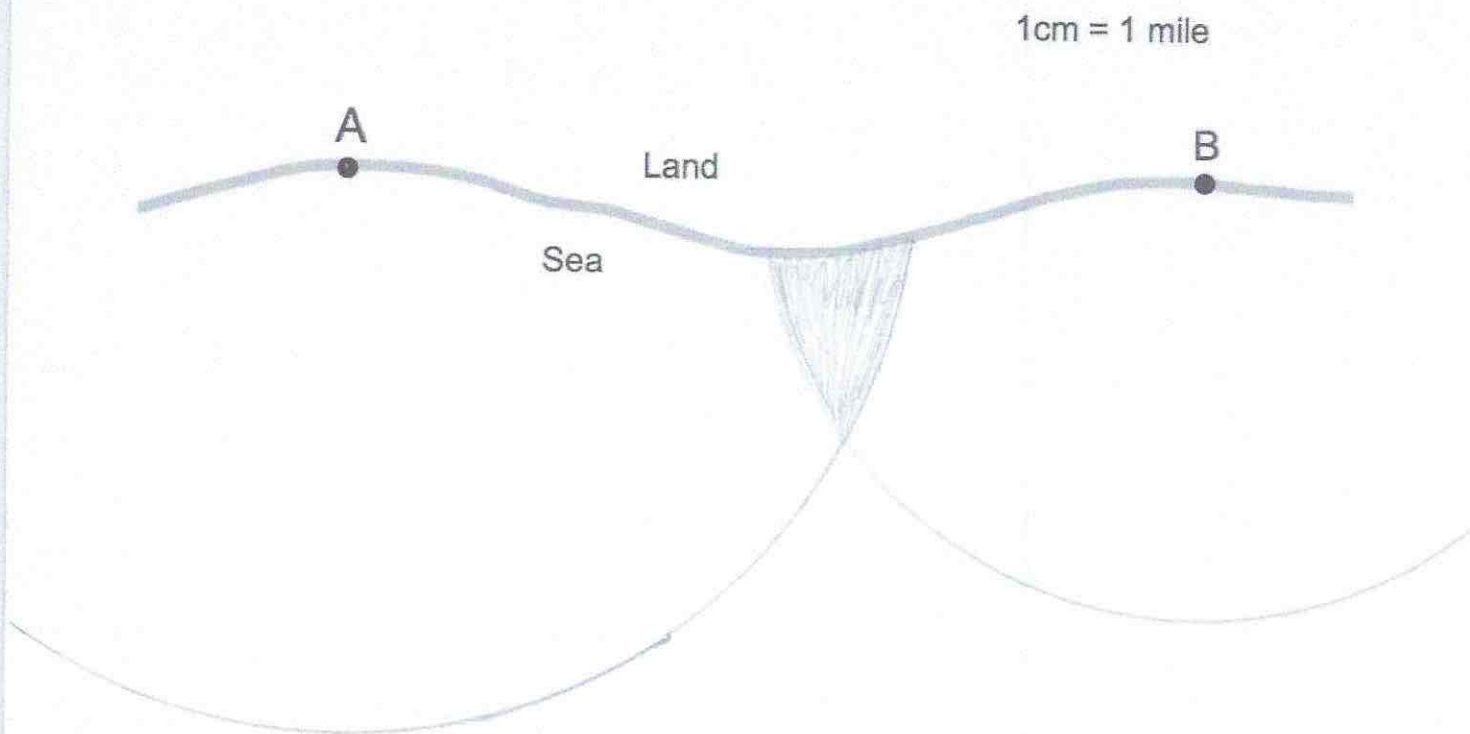

(2)

13. Below is a solid.

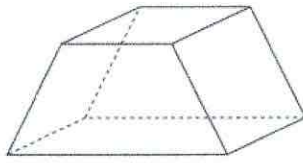

(a) Write down the number of faces

.....6.....
(1)

(b) Write down the number of vertices

.....8.....
(1)

14. Below are the nets of two solid shapes.

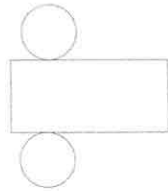

A

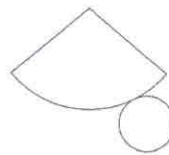

B

(a) Write down the shape that is made from Net A.

.....cylinder.....
(1)

(b) Write down the shape that is made from Net B.

.....cone.....
(1)

15. Shown below is a solid shape made from centimetre cubes.

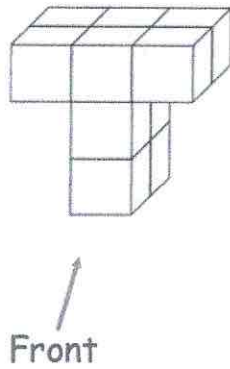

(a) On the centimetre square grid, draw the front elevation.

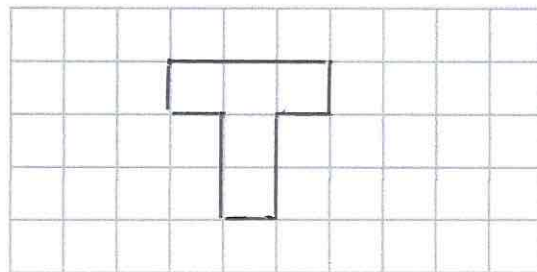

(2)

(b) On the centimetre square grid, draw the plan view.

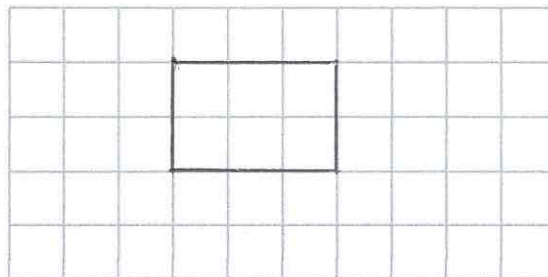

(2)

16. This is a map of an island.

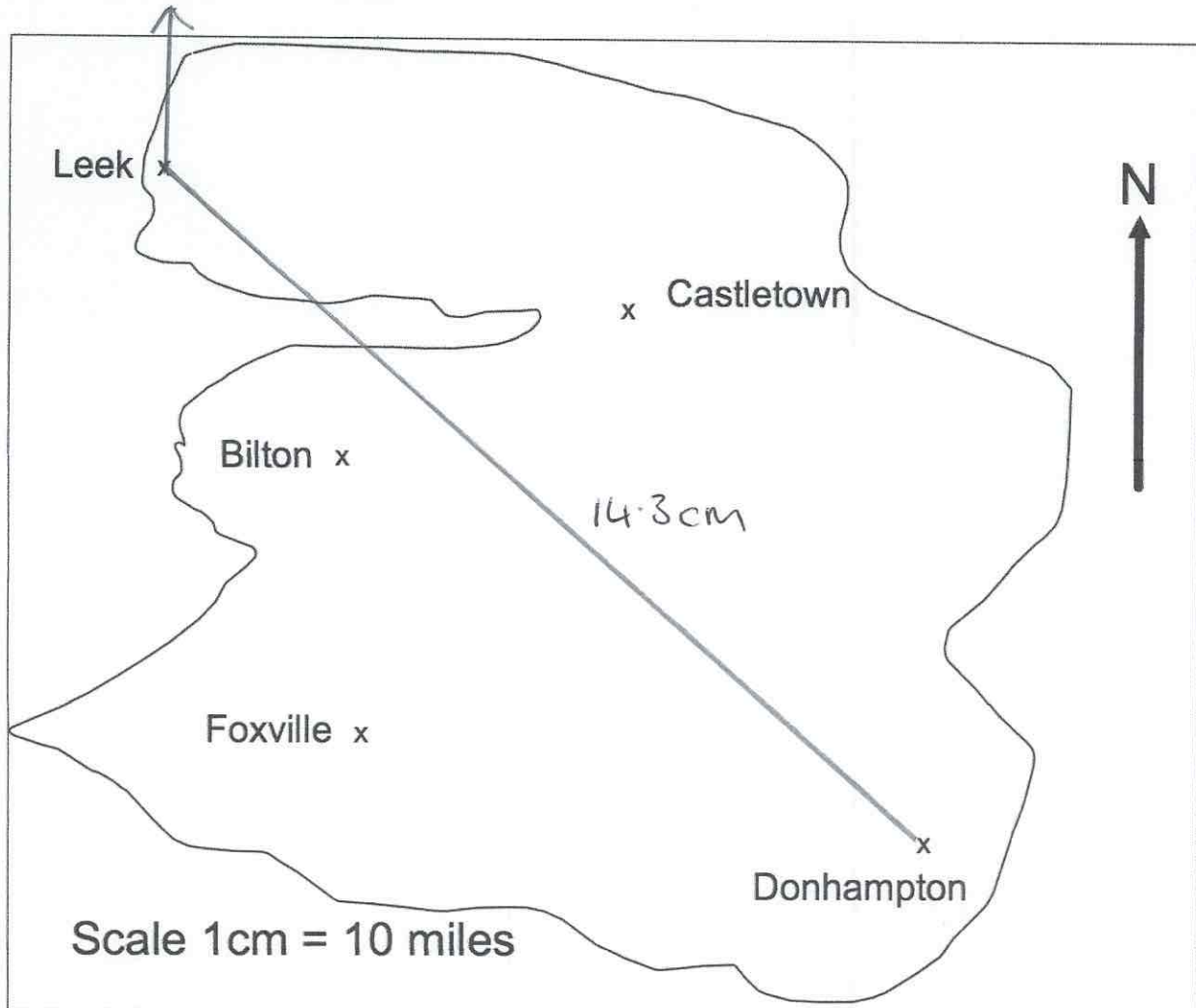

A helicopter flies in a straight line from Leek to Donhampton.

(a) How far does the helicopter fly?

$$14.3 \times 10$$

* depends on printing size

.....143.....miles
(2)

(b) Write down the bearing of Donhampton from Leek.

.....132.....°
(1)

17. The diagram shows a scale drawing.

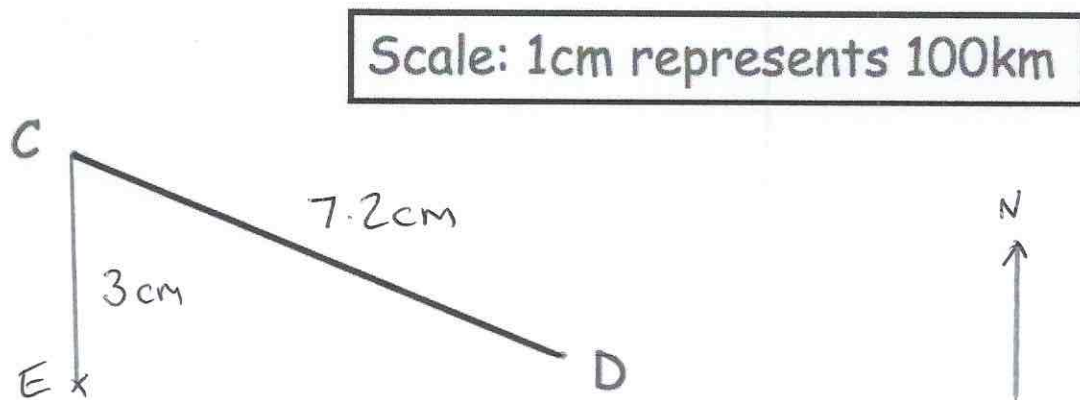

- (a) Use the diagram to calculate the actual distance from C to D.

$$7.2 \times 100 = 720$$

$$\dots\dots\dots 720 \dots\dots \text{km}$$

(2)

E is 300km due south of C.

- (c) Show E on the diagram. 3cm

(1)

18. The distance from Leek to Milton is 310 miles.
A train travels this distance in 4 hours 15 minutes.

Calculate the average speed of the train.

$$\frac{310}{4.25} = 72.9411\dots \text{mph}$$

$$\dots\dots\dots 72.94 \dots\dots \text{mph}$$

(3)

19. Iron has a density of 7.8g/cm^3 .
A solid iron statue has a mass of 877.5g .
Work out the volume of the statue.

$$V = \frac{m}{d} \qquad \frac{877.5}{7.8}$$

..... 112.5 cm^3
(2)

- 20.

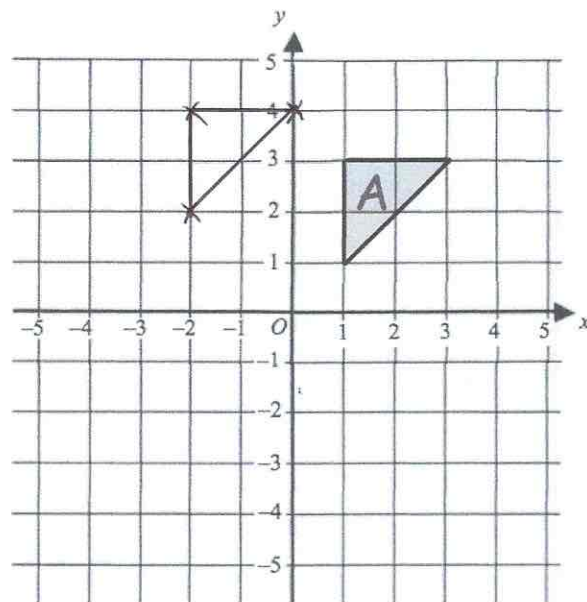

Translate triangle A by the vector $\begin{pmatrix} -3 \\ 1 \end{pmatrix}$

(2)

21. The perimeter of a parallelogram is 17cm.
The length of each long side is 5cm.

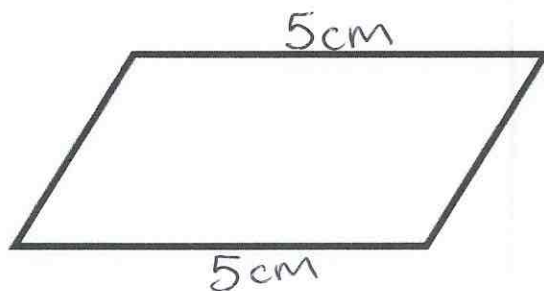

Work out the length of each short side.

$$\begin{aligned}5 + 5 &= 10 \\17 - 10 &= 7 \\7 \div 2 &= 3.5\end{aligned}$$

..... 3.5cm
(2)

- 22.

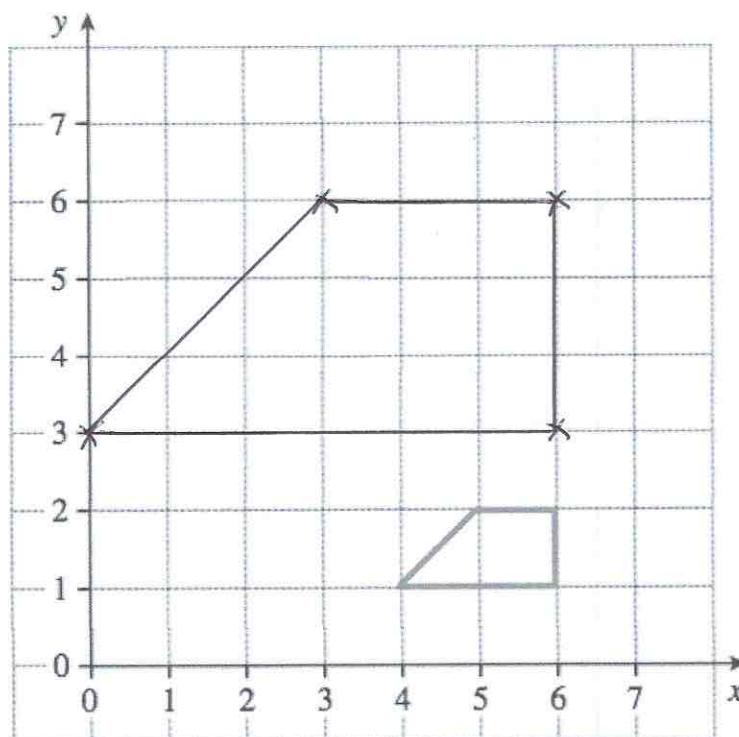

Enlarge the trapezium by scale factor 3, centre (6, 0).

(2)

23. Below is a cylinder with radius 2cm and height 5cm.

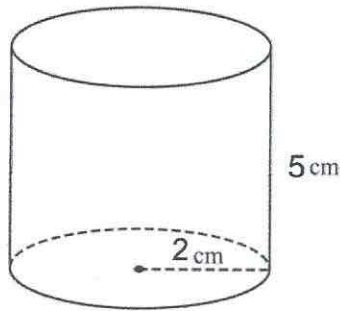

Calculate the volume of the cylinder.

$$\begin{aligned} V &= \pi \times r^2 \times h \\ &= \pi \times 2^2 \times 5 \\ &= 20\pi \end{aligned}$$

.....62.83.....cm³
(3)

24. Bethany drove to a family meal and then back home.
The meal was at a restaurant that is 70 kilometres from her home.

Bethany left home at 10:00 and arrived at the restaurant at 11:30.
She stayed at the family meal for 2 hours.
Bethany then drove home at a speed of 35 kilometres per hour.

Show this information on the distance-time graph.

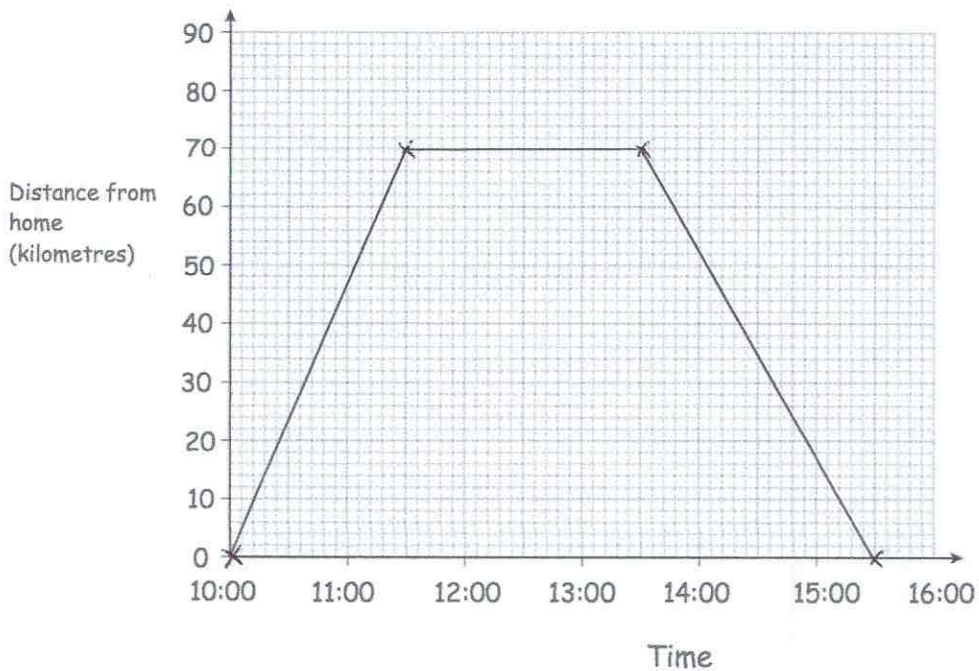





$$\frac{70}{35} = 2$$

(3)

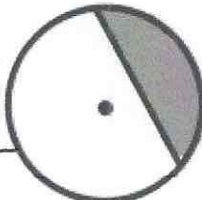
25. Here are 6 diagrams and 6 labels.
 In the diagram the centre of the circle is shown with a dot.

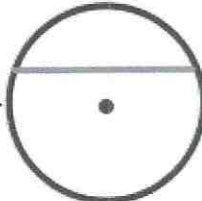
Match each diagram to its label.
 One has been done for you.

| Label | Diagram |
|---------------------|---|
| Circle and radius |  |
| Circle and segment |  |
| Circle and arc |  |
| Circle and diameter |  |
| Circle and tangent |  |
| Circle and chord |  |

26. A cone has base radius 5cm and perpendicular height 9cm.

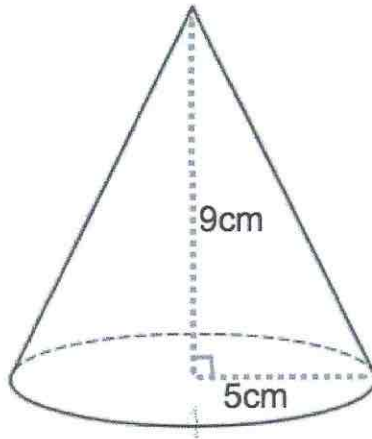

Work out the volume of the cone.

$$\frac{1}{3} \times \pi \times 5^2 \times 9$$

$$\underline{\underline{235.62}} \text{ cm}^3$$

(3)

- 27.

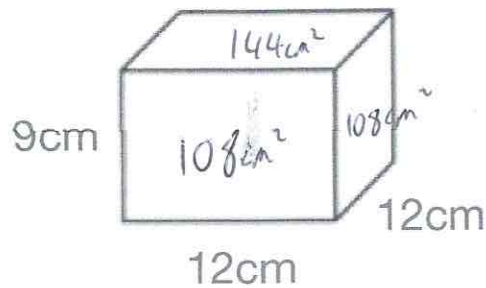

Work out the surface area of this cuboid.
State the units of your answer.

$$108 + 108 + 108 + 108 + 144 + 144$$

$$= 720 \text{ cm}^2$$

$$\underline{\underline{720}} \text{ cm}^2$$

(3)

28. A sphere has a radius of 5cm.

Calculate the surface area of the sphere.

$$4 \pi r^2$$

$$4 \times \pi \times 5^2 = 100\pi$$

$$\dots\dots\dots 314.2 \text{ cm}^2$$

(3)

29. A theatre has 46 rows.



There are 42 seats in each row.

During a show at the theatre, there are 50 empty seats.

Work out how many people are watching the show.

$$\begin{array}{r} 46 \\ \times 42 \\ \hline 92 \\ 1840 \\ \hline 1932 \end{array}$$

$$\begin{array}{r} 1932 \\ - 50 \\ \hline 1882 \end{array}$$

$$\dots\dots\dots 1882$$

(3)

30. Paul has £10 to buy rulers at 60p each.



What change should he get if he buys as many as possible?

$$60 \overline{) 1000} \text{ r } 40$$

$$\dots\dots\dots 40\text{p}$$

(3)

31. The table below shows how many washing machines and dishwashers were sold by a shop over three months.



| | Washing Machines | Dishwashers |
|-------|------------------|-------------|
| April | 92 | 65 |
| May | 70 | 72 |
| June | 104 | 68 |
| | <u>266</u> | <u>205</u> |

Work out how many more washing machines than dishwashers were sold in total over the three months.

$$\begin{array}{r} 266 \\ - 205 \\ \hline 61 \end{array}$$

.....61.....
(3)

32. Find the missing numbers below.



$$\begin{array}{r} \boxed{8} \quad \cancel{2} \quad 4 \\ - 1 \quad 5 \quad \boxed{5} \\ \hline 6 \quad \boxed{6} \quad 9 \end{array}$$

(2)

33. Holly works out the answer to $135.66 + 193.88$ on a calculator.

Her answer is 329.54

(a) Round her answer to the nearest 10.

330
(1)

(b) Round her answer to the nearest 100.

300
(1)

(c) Round her answer to the nearest integer.

330
(1)

(d) Round her answer to one decimal place.

329.5
(1)

34. Use approximations to estimate the value of



$$\frac{596.4 \times 2.06}{0.521}$$

0.521

2
2

$$\frac{1200}{0.5} = 2400$$

$$\frac{600 \times 2}{0.5}$$

2400
(3)

35. Given



$$a = 11 - 3^2$$

$$b = \frac{60}{2+3}$$

$$c = 18 - 3 \times 2 + 1$$

Work out the value of $a + b + c$

$$a = 2$$

$$b = 12$$

$$c = 13$$

$$2 + 12 + 13 = 27$$

$$\begin{array}{r} \dots\dots\dots 27 \dots\dots\dots \\ \hline \end{array} \quad (4)$$

36. Roy is saving money.



In January, he saves £28.65

In February, he saves £14.82

In March, he saves £22.77

Work out how much money Roy has saved in total.

$$\begin{array}{r} 28.65 \\ 14.82 \\ + 22.77 \\ \hline 66.24 \end{array}$$

$$\begin{array}{r} \text{£} \dots\dots\dots 66.24 \dots\dots\dots \\ \hline \end{array} \quad (2)$$

37. Megan says "when you square root a number, the answer is always smaller."



Show she is wrong.

$$\sqrt{1} = 1$$

$$\sqrt{0} = 0$$

(2)

38. The attendance at Frome United versus Trowbridge Rovers was 8,701.



Of this crowd, five-sevenths supported Frome United.
Calculate how many people did not support Frome United.

$$8701 \div 7 = 1243$$

$$1243 \times 5 = 6215$$

$$8701 - 6215$$

.....2486.....

(3)

39. Hannah is baking two cakes.



One cake needs $1\frac{1}{3}$ cups of milk.
Hannah has $1\frac{1}{4}$ cups of milk.

How much more milk does Hannah need?

$$1\frac{1}{3} \times 2 = 2\frac{2}{3}$$

$$2\frac{2}{3} - 1\frac{1}{4} = 1\frac{5}{12}$$

..... $1\frac{5}{12}$cups

(3)

40. Work out



$$1\frac{1}{3} \times 2\frac{2}{5}$$

Give your answer as a mixed number.

$$\frac{4}{3} \times \frac{12}{5} = \frac{48}{15}$$

$$3\frac{3}{15}$$

$$\frac{3\frac{1}{5}}{\dots\dots\dots}$$

(3)

41. Work out



$$\frac{5}{13} \div \frac{2}{3}$$

$$\frac{5}{13} \times \frac{3}{2} = \frac{15}{26}$$

$$\frac{15}{26}$$

(1)

42. Write down the reciprocal of 0.35

$$0.35 = \frac{7}{20}$$

$$\frac{7}{20} \rightarrow \frac{20}{7}$$

$$\frac{20}{7}$$

(1)

43. A primary school has a running track.
It has two straights of 50 metres.
Also there are two 'bends' that are semicircles with diameter 30 metres.

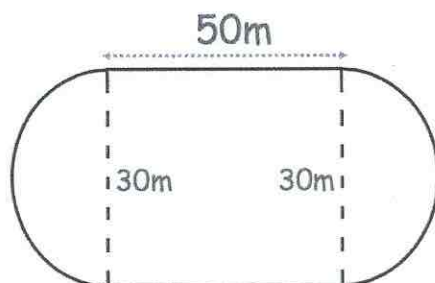

Work out the distance around the running track.

$$a+b = \text{full circle}$$

$$\pi \times 30 = 94.2477 \dots \text{m}$$

$$50 + 50 + 94.247$$

$$\dots 194.25 \dots \text{m}$$

(5)

44. Joanne sees this special offer in a shop.



Special Offer

| | |
|---------|------|
| Laptop | £465 |
| Printer | £109 |

Buy both items and receive a 10% discount

Joanne buys both items.

How much does she pay?

$$465 + 109 = 574$$

$$574 \div 100 = 5.74$$

$$5.74 \times 4 = £22.96$$

$$574 - 22.96$$

$$£ \dots 551.04 \dots$$

(3)

45. The diagram shows a rectangle with a circle cut out.

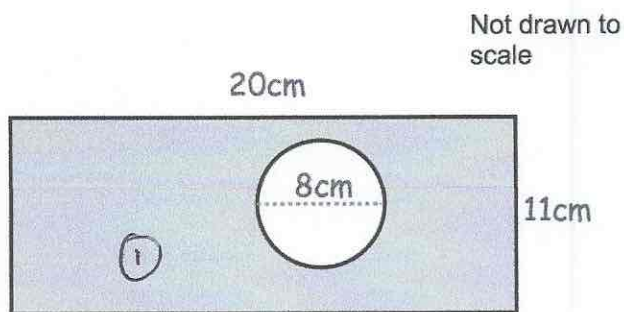

The rectangle has length 20cm and width 11cm.
The circle has diameter 8cm.

Work out the shaded area.
Give your answer correct to 2 decimal places.

$$\begin{aligned} \textcircled{1} \quad 20 \times 11 &= 220 \text{ cm}^2 \\ \textcircled{2} \quad \pi \times 4^2 &= 50.265\dots \\ 220 - 50.265\dots & \end{aligned}$$

$$\dots 169.73 \dots \text{ cm}^2$$

(4)

46. Lauren is given a 12% pay rise.
Her new salary is £24,080

What was Lauren's salary before the pay rise?

$$\begin{aligned} 112\% &\rightarrow 24080 \\ 1\% &\rightarrow 215 \\ 100\% &\rightarrow 21500 \end{aligned}$$

$$\pounds 21,500 \dots$$

(3)

47. Chris and Molly win money in a competition.
They share the money in the ratio 2 : 3
Molly receives £240.

(a) How much money does Chris receive?

$$240 \div 3 = 80$$
$$80 \times 2 = 160$$

£.....160.....
(2)

(b) How much money did they win in the competition?

$$240 + 160$$

£.....400.....
(1)

-
48. Sophie went to Spain.
She changed £225 into euros (€).

The exchange rate was £1 = €1.62

(a) Change £225 into euros (€).

$$225 \times 1.62$$

€.....364.50.....
(2)

On her return to England, Sophie changed €66 into pounds (£)

The new exchange rate was £1 = €1.50

(b) Change €66 into pounds (£).

$$66 \div 1.5$$

£.....44.....
(2)

49. Thomas has a recipe for making Rice Krispie cakes.
The recipe uses 120g of chocolate and 80g of Rice Krispies to make 12 cakes.

(a) How much chocolate should Thomas use to make 30 cakes?

$$120 \div 12 = 10 \text{ g per cake}$$

$$30 \times 10$$

$$\dots 300 \dots \text{g}$$

(2)

(b) What is 120g out of 200g expressed as a percentage?

$$\frac{120}{200} = \frac{60}{100}$$

$$\dots 60 \dots \%$$

(1)

50. A number, n , is rounded to 1 decimal place.
The result is 1.3

Using inequalities, write down the error interval for n .

$$\dots 1.25 \leq n < 1.35 \dots$$

(2)

51.

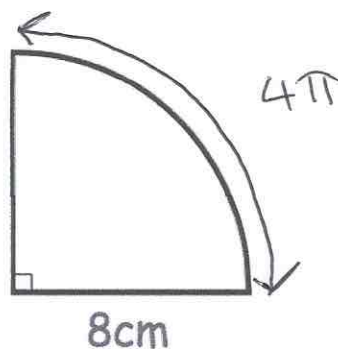

Calculate the perimeter of the sector.

$$C = \pi \times 16$$
$$= 16\pi$$

$$16\pi \div 4 = 4\pi$$

$$8 + 8 + 4\pi$$

$$\dots 28.6 \dots \text{cm}$$

(2)

52.

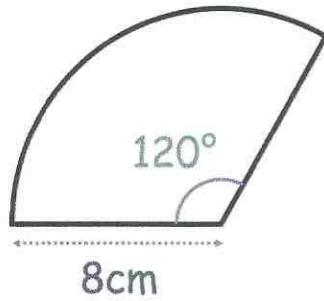

Calculate the area of the sector.

$$\frac{120}{360} \times \pi \times 8^2$$

.....67.02.....cm²
(2)

53. 100 students study one language at a college.

Some students study French.
Some students study Spanish.
The rest of the students study German.

54 of the students are in Year 12.
20 of the 29 students who study Spanish are in Year 13.
31 students study German.
15 Year 13 students study French.

Work out the number of Year 12 students who study German.

| | Yr 12 | Yr 13 | Total | |
|---------|-------|-------|-------|---------------------|
| French | 25 | 15 | 40 | |
| Spanish | 9 | 20 | 29 | |
| German | 20 | 11 | 31 | |
| Total | 54 | 46 | 100 |20..... (4) |

54. The pictogram shows the amount of money raised by students in some tutor groups at a school.

Key ○ = £10

| Tutor group | | Raised |
|-------------|-------------|--------|
| S | ○ ○ ○ ○ ○ ○ | £60 |
| T | ○ ○ ○ | £30 |
| E | ○ ○ ○ ○ ◐ | £45 |
| P | ○ ○ ○ ◐ | £35 |

- (a) Complete the raised column. (2)
- (b) Complete the pictogram for tutor group E. (2)
- (c) How much money was raised altogether?

$$60 + 30 + 45 + 35$$

£.....170.....
(1)

55.

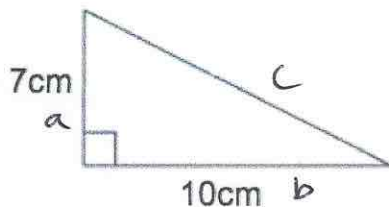

Shown is a right-angled triangle.

Work out the perimeter of the triangle

$$\begin{aligned}
 a^2 + b^2 &= c^2 \\
 7^2 + 10^2 &= c^2 \\
 49 + 100 &= c^2 \\
 c^2 &= 149 \\
 c &= 12.20655\dots
 \end{aligned}$$

$$7 + 10 + 12.206$$

$$\dots 29.2 \dots \text{cm} \quad (4)$$

56. A rugby team can win, draw or lose a match.
The table shows the probabilities of each result.

| Result | Win | Draw | Lose |
|-------------|-----|------|------|
| Probability | 0.4 | 0.35 | |

(a) Calculate the missing probability in the table.

$$\begin{aligned}
 0.4 + 0.35 &= 0.75 \\
 1 - 0.75 &= 0.25
 \end{aligned}$$

$$\dots 0.25 \dots \quad (2)$$

Each win is worth 2 points.
Each draw is worth 1 point.
Each loss is worth 0 points.
The rugby team plays 20 games in a season.

(b) Work out how many points the rugby team should receive in one season.

$$\begin{aligned}
 20 \times 0.4 &= 8 \text{ wins} \\
 20 \times 0.35 &= 7 \text{ draws} \\
 20 \times 0.25 &= 5 \text{ losses}
 \end{aligned}$$

$$\dots 23 \dots \quad (3)$$

$$\begin{aligned}
 8 \times 2 &= 16 \\
 7 \times 1 &= 7 \\
 \hline
 &23
 \end{aligned}$$

57. William is going to attend a two day summer camp at his local leisure centre. He can take part in one activity on Monday and one activity on Tuesday.

| Monday | Tuesday |
|----------|-------------|
| Golf | Ice-skating |
| Football | Swimming |
| Rugby | Dodgeball |
| Hockey | Basketball |

List all the possible combinations of activity he can take part in.

GI FI RI HI

 GS FS RS HS

 GD FD RD HD

 GB FB RB HB

(2)

58. Triangle ABC has a right angle.
 Angle BAC is 25°
 AC = 12.5cm

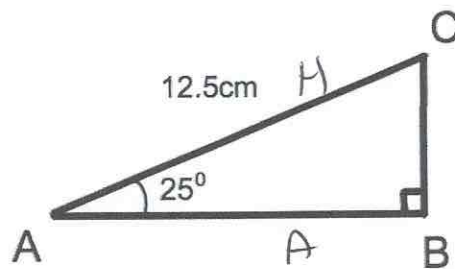

Not to scale

Calculate the length of AB

$$AB = \cos(25) \times 12.5$$

.....11.33.....cm
 (3)

59. Shown below is a trapezoid prism.

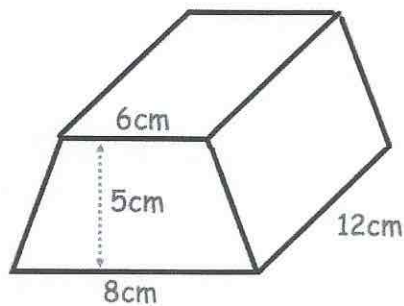

Find the volume of the prism.

$$\frac{1}{2} (6+8) \times 5$$

$$7 \times 5 = 35$$

$$35 \times 12 = 420$$

..... 420 cm³
(4)

60. There are 80 students in year 11.

9 students study French and German.
 35 students only study French
 2 students do not study French or German.

(a) Complete the Venn diagram

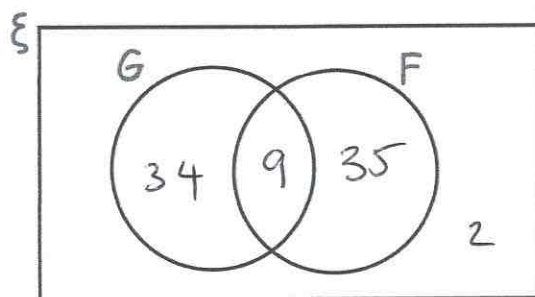

(2)

(b) Work out how many students study only German.

..... 34
(1)

61. Write the following numbers in order of size.
Start with the largest number.

0.7 0.09 0.269 0.47 0.9

0.9, 0.7, 0.47, 0.269, 0.09.....
(1)

62. (a) Write down two multiples of 7.

7..... and 49.....
(1)

- (b) Write down two multiples of 9.

9..... and 18.....
(1)

- (c) Write down a number which is a multiple of both 7 and 9.

63.....
(1)

63. Simplify $9h + 5k + 4h - 8k$

$13h - 3k$
(2)

64. Write down all the prime numbers between 10 and 20.

11, 13, 17, 19.....
(2)

65. From the list of numbers

3 6 8 14 16 28 41 64

write down the cube root of 27.

.....3.....
(1)

66. Work out the n th term for this sequence

| | | | | | | | |
|-------|---|----|----|----|----|-----|-----|
| | 8 | 17 | 26 | 35 | 44 | ... | ... |
| a_n | 9 | 18 | 27 | 36 | | | |

..... $a_n - 1$
(2)

67. (a) Write 50 as a product of its prime factors.

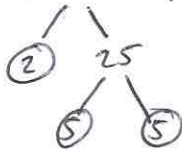

..... 2×5^2
(2)

(b) Find the Lowest Common Multiple (LCM) of 32 and 50.

$$32 = 2 \times 2 \times 2 \times 2 \times 2$$



.....800.....
 $LCM = 2 \times 2 \times 2 \times 2 \times 2 \times 5 \times 5$ (2)

68. Tilly the dog barks every 9 seconds.
Billy the dog barks every 12 seconds.
They both bark at the same time.

After how many seconds will they next bark at the same time?

| | | | |
|----|----|----|----|
| 9 | 18 | 27 | 36 |
| 12 | 24 | 36 | |

.....36 seconds.....
(2)

69. (a) Factorise $x^2 + 2x - 24$

$$\dots\dots\dots (x+6) \dots\dots\dots (x-4) \\ (2)$$

(b) Factorise $x^2 - 25$

$$\dots\dots\dots (x+5) \dots\dots\dots (x-5) \\ (1)$$

70. Solve $4y + 1 = 6y + 26$

$$\begin{array}{r} -4y \quad -4y \\ 1 = 2y + 26 \\ -26 \quad -26 \\ \hline -25 = 2y \end{array}$$

$$y = -12.5$$

$$y = \dots\dots\dots -12.5 \dots\dots\dots \\ (2)$$

71. Calculate 3^6

$$\dots\dots\dots 729 \dots\dots\dots \\ (1)$$

72. On the grid, draw $x + 2y = 6$ for values of x from -2 to 2 .

| | | | | | |
|-----|----|-----|---|-----|---|
| x | -2 | -1 | 0 | 1 | 2 |
| y | 4 | 3.5 | 3 | 1.5 | 2 |

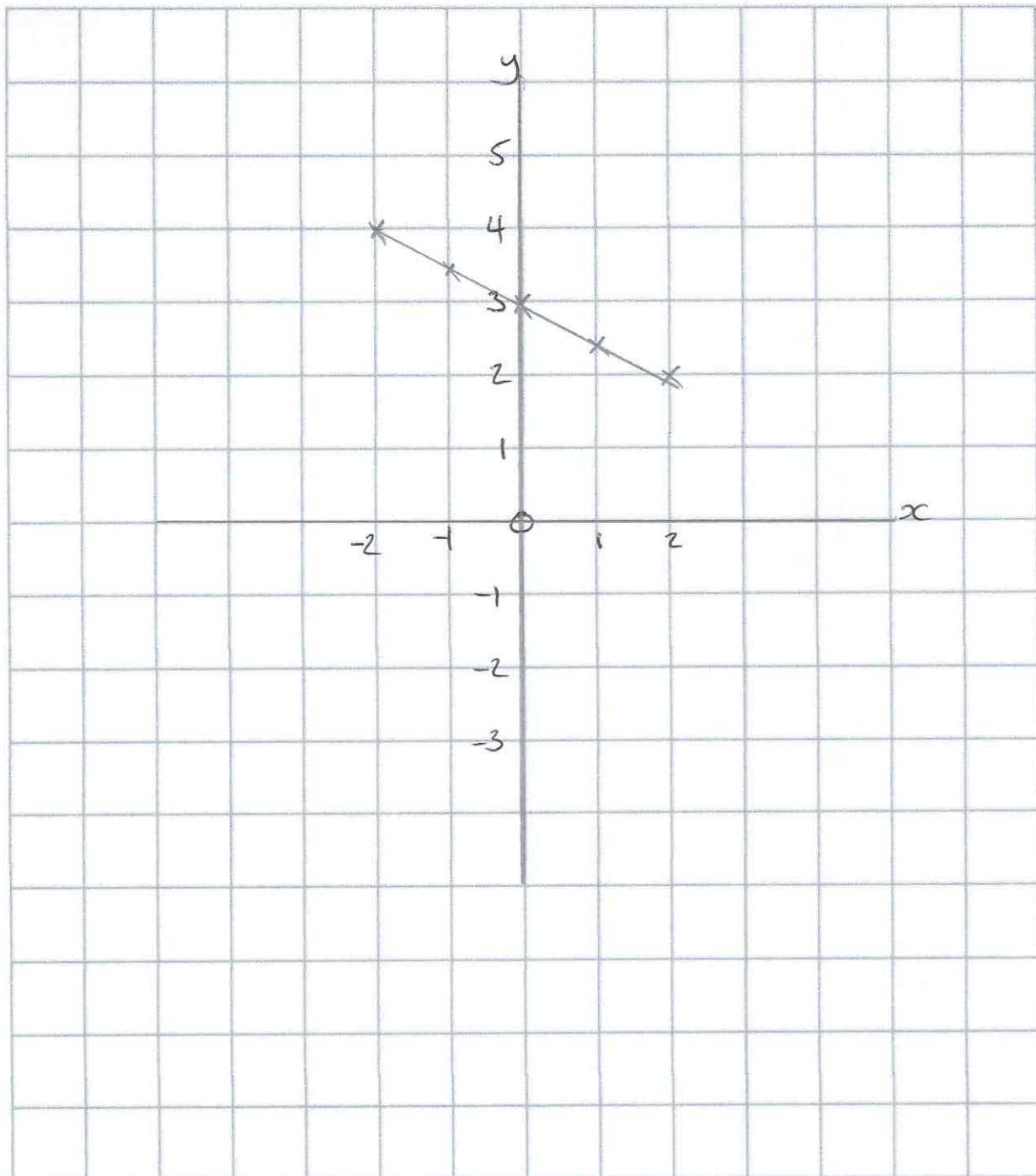

(4)

73. The graph below shows the depth of water in a container.

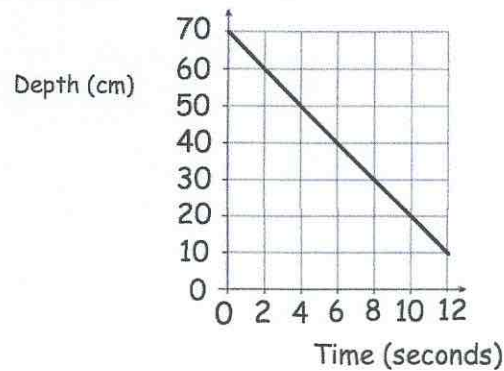

(a) Write down the gradient of the line

$$\frac{-50}{10}$$

$$\dots\dots\dots -5 \dots\dots\dots (1)$$

(b) What does the gradient of the line represent?

The change in depth of the water each second. (1)

74. Make w the subject of the formula

$$y = 3w - a$$

$$y + a = 3w$$

$$\div 3 \quad \div 3$$

$$\frac{y+a}{3} = w$$

$$w = \frac{y+a}{3} \dots\dots\dots (2)$$

75. Solve the simultaneous equations

$$2x + 4y = 26$$

$$3x - y = 4$$

Do not use trial and improvement

$$2x + 4y = 26$$

$$12x - 4y = 16$$

$$14x = 42$$

$$x = 3$$

$$3 - y = 4$$

$$y = -1$$

check

$$6 + 20 = 26$$

$$x = 3 \dots\dots\dots y = -1 \dots\dots\dots (3)$$

76. (a) Complete the table of values for $y = x^2 - 3x$

| | | | | | | | |
|-----|----|----|---|----|----|---|---|
| x | -2 | -1 | 0 | 1 | 2 | 3 | 4 |
| y | 10 | 4 | 0 | -2 | -2 | 0 | 4 |

(2)

(b) On the grid, draw the graph of $y = x^2 - 3x$ for the values of x from -2 to 4.

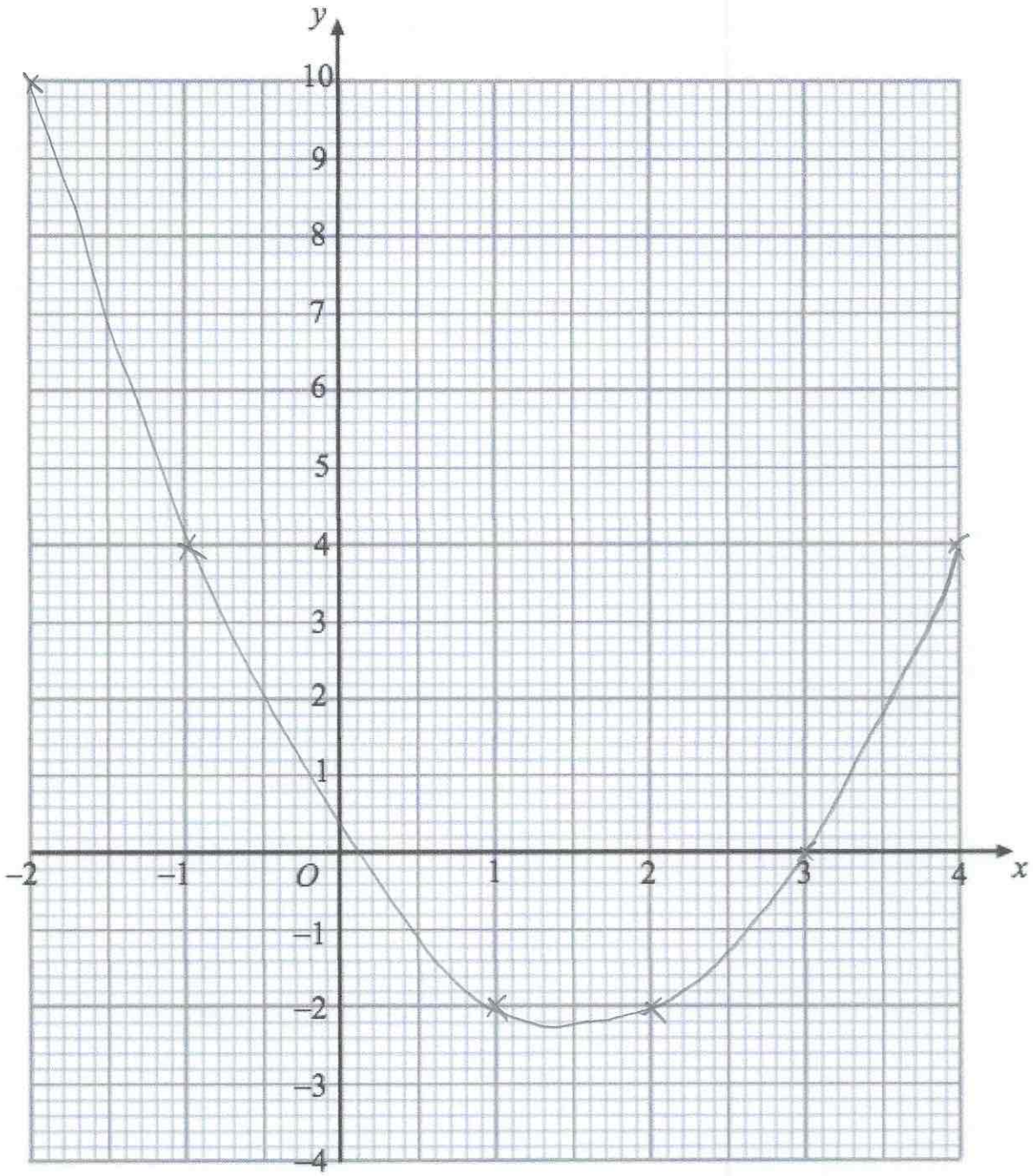

(2)

77. Work out

$$10^{-2}$$

Give your answer as a decimal.

$$\frac{1}{10^2}$$

$$\frac{1}{100}$$

$$\dots\dots\dots 0.01 \dots\dots\dots$$

(2)

78. Complete the table.

| Fraction | Decimal | Percentage |
|-----------------|---------|------------|
| $\frac{17}{20}$ | 0.85 | 85% |
| $\frac{3}{25}$ | 0.12 | 12% |
| $\frac{23}{25}$ | 0.92 | 92% |

(4)

79. Nina invested £1500 for 4 years at 2.5% per annum simple interest.

Work out the total amount of money in the account at the end of 4 years.

$$\begin{aligned} 1500 \div 100 &= 15 \\ 15 \times 2.5 &= 37.50 \\ 37.50 \times 4 &= 150 \\ 1500 + 150 & \end{aligned}$$

$$\pounds \dots\dots\dots 1650 \dots\dots\dots$$

(3)

80. Fiona leaves £1600 in the bank for four years.
It earns compound interest of 4% each year.

Calculate the total amount Fiona has in the bank at the end of the four years.

$$1600 \times 1.04^4 = 1871.773\dots$$

$$\pounds \dots\dots\dots 1871.77 \dots\dots\dots$$

(3)

81. Work out the difference between -3°C and 4°C

.....7..... $^{\circ}\text{C}$
(1)

At 5am the temperature is -6°C

By 2pm the temperature went up by 9°C 3°C

From 2pm to 11pm the temperature went down by 15°C

(b) Work out the temperature at 11pm

.....-12..... $^{\circ}\text{C}$
(2)

82. Here are four digits.

9 4 7 5

(a) Use two of these digits to make the largest possible two-digit number.

.....97.....
(1)

(b) Use all four of these digits to make the four-digit number closest to 5000.

.....4975.....
(1)

83. A shop sells umbrellas.
The scatter graph shows information about the number of umbrellas sold each week and the rainfall that week, in millimetres.

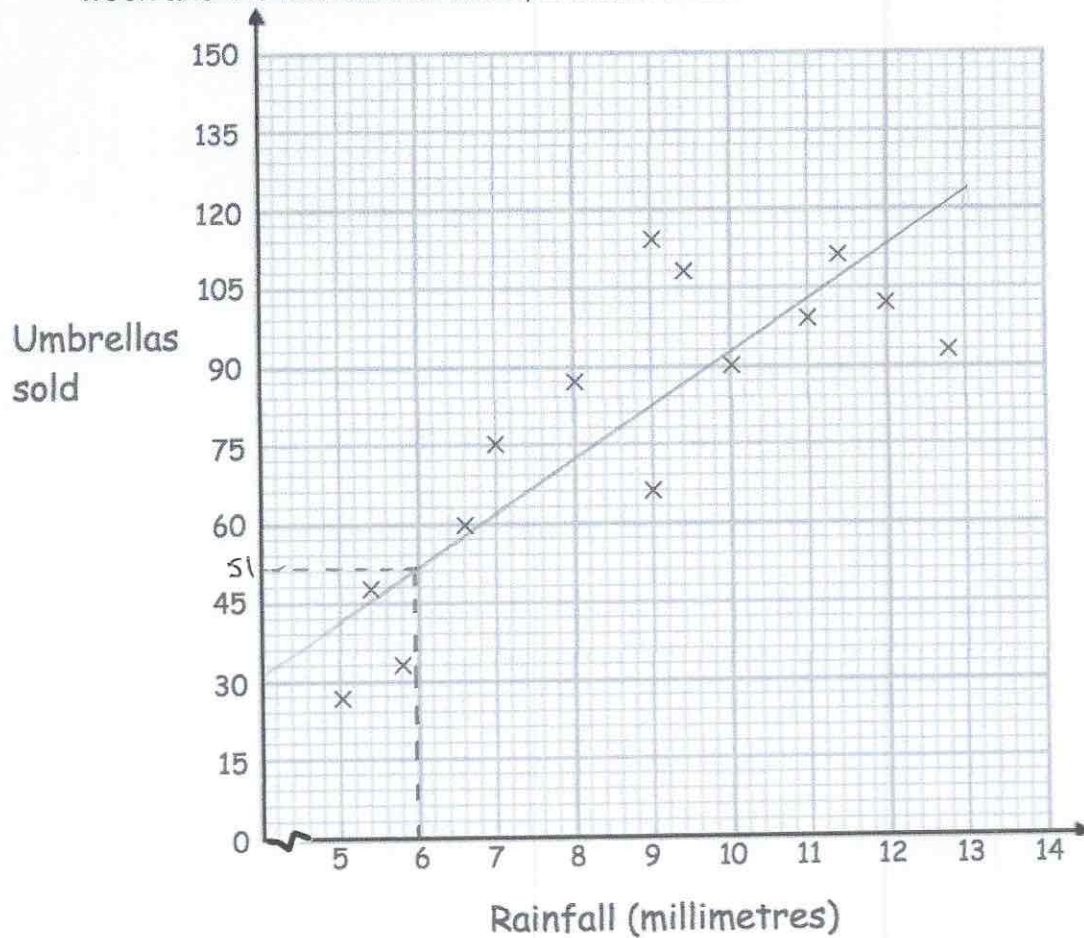

- (a) Describe the relationship between the rainfall and umbrellas sold.

As the rainfall increases, so does the number of umbrellas sold.

(1)

- (b) What is the greatest amount of rainfall in one week?

12.8mm

(1)

In another week, there was 6mm of rain.

- (c) Estimate the number of umbrellas sold.

51

(2)

- (d) Explain why it may **not** be appropriate to use your line of best fit to estimate the number of umbrellas sold in a week with 25mm of rainfall.

Extrapolation is unreliable

25mm is beyond the range of given data

(1)

84. Shown below are five cards which are arranged in order from smallest to largest



The range of the cards is 4.

The median of the cards is 8.

The mean of the cards is 7.

Work out the 4 missing numbers.

$$5 \times 7 = 35$$

$$5 + 8 + 9 = 22$$

$$35 - 22 = 13$$

5, 8, 8 and 9

(4)

85.

| Name | Price (£) | Mass (kg) | Thickness (cm) | Battery (minutes) |
|-------|-----------|-----------|----------------|-------------------|
| Epic | £799 | 1.23 | 1.89 | 690 |
| Bell | £1249 | 1.2 | 1.52 | 650 |
| Lemon | £1599 | 1.37 | 1.49 | 720 |
| HB | £799 | 1.28 | 1.7 | 740 |
| Lazer | £1049 | 1.35 | 1.66 | 660 |

(a) Which laptop is the thickest?

..... Epic
(1)

(b) How much longer does the HB battery last than the Bell battery?

740 - 650

..... 90 mins
(1)

86. The points A (0, 3), C (2, -3) and D (-2, -2) are shown.

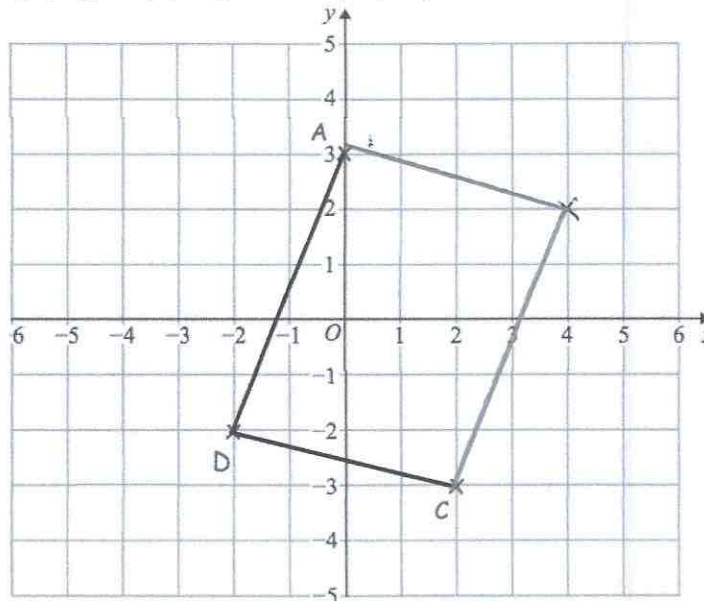

ABCD is a parallelogram.

Complete the parallelogram and write down the coordinates of B.

(..... 4, 2)
(2)

87. (a) Simplify

$$m^9 \times m^2$$

$$\frac{m^{11}}{\dots\dots\dots} \quad (1)$$

(b) Simplify

$$\frac{m^{10}}{m^2}$$

$$\frac{m^8}{\dots\dots\dots} \quad (1)$$

(c) Simplify

$$(m^3)^6$$

$$\frac{m^{18}}{\dots\dots\dots} \quad (1)$$

88. Solve the inequality $5x + 11 \geq 2$

$$-11 \quad -11$$

$$5x \geq -9$$

$$x \geq -1.8$$

$$\frac{x \geq -1.8}{\dots\dots\dots} \quad (2)$$

89.

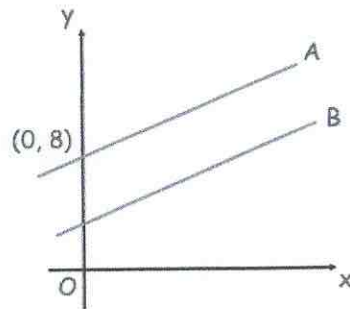

The lines A and B are parallel.
The line A passes through the point (0, 8)
The line B has equation $y = 3x + 4$

Write down the equation of line A

$$\underline{y = 3x + 8}$$

(2)

90. $y = w - 2a^2$

$w = 400$

$a = 5$

Work out the value of y .

$$\begin{aligned} y &= 400 - 2 \times 5^2 \\ &= 400 - 2 \times 25 \\ &= 400 - 50 \end{aligned}$$

$$\underline{\quad 350 \quad}$$

(2)

91 (a) Complete the table of values for $y = x^3 - 2x + 3$

| | | | | | |
|---|----|----|---|---|---|
| x | -2 | -1 | 0 | 1 | 2 |
| y | -1 | 4 | 3 | 2 | 7 |

(2)

(b) On the grid, draw the graph of $y = x^3 - 2x + 3$ for the values of x $-2 \leq x \leq 2$

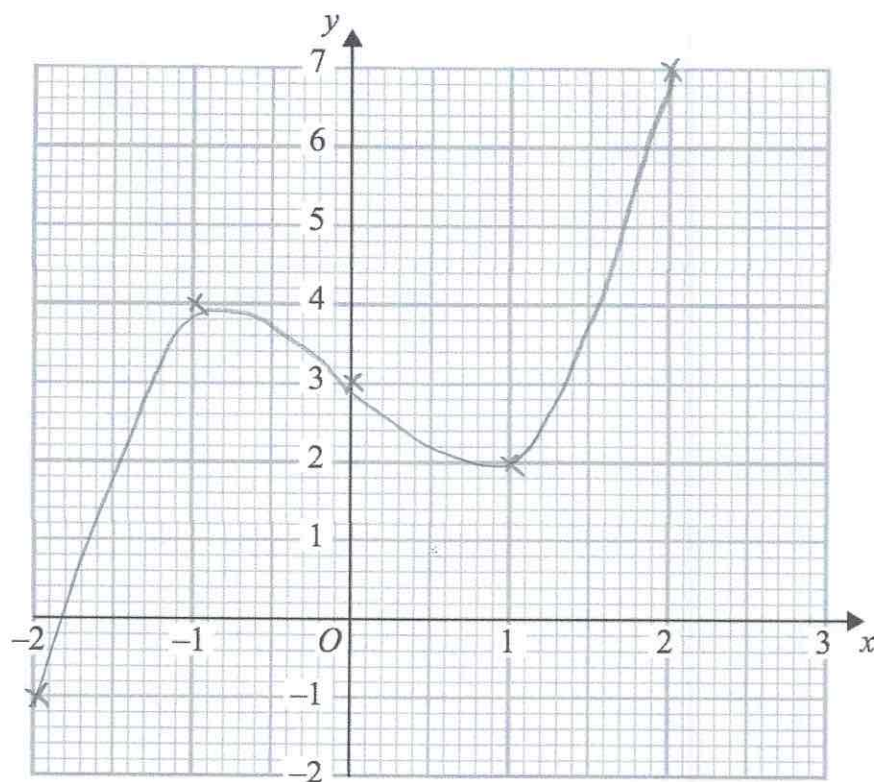

(2)

92. (a) Complete the table of value for $y = \frac{4}{x}$

| | | | | | | |
|---|-----|---|---|---|-----|-----|
| x | 0.5 | 1 | 2 | 4 | 8 | 10 |
| y | 8 | 4 | 2 | 1 | 0.5 | 0.4 |

(2)

(b) On the grid, draw the graph of $y = \frac{4}{x}$ for $0.5 \leq x \leq 10$

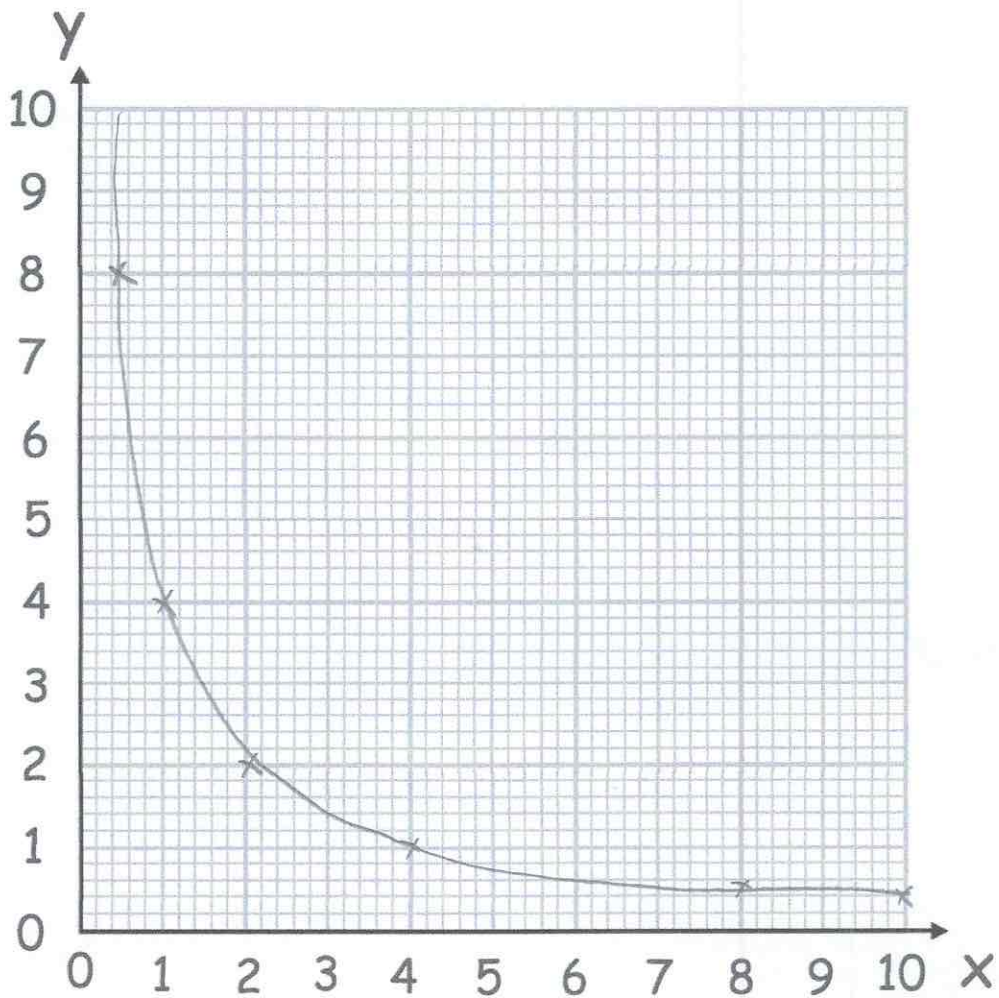

(2)

93. The mass of a 2p coin is 7g.

Find the mass of £6 worth of 2p coins.
Give your answer in kilograms.

$$600 \div 2 = 300$$
$$300 \times 7 = 2100g$$

.....2.1.....kilograms
(4)

94. A glass contains water.

Below are four estimates of the amount of water in the glass.
Circle the most appropriate estimate.

25ml

25L

250ml

2.5L

(1)

95. The distance chart below shows the distance, in miles, between some towns and cities.

| | | | |
|-----------|---------|---------|--------------|
| Cambridge | | | |
| 54 | Ipswich | | |
| 64 | 45 | Norwich | |
| 43 | 82 | 78 | Peterborough |

- (a) Write down the distance between Ipswich and Peterborough.

.....82..... miles
(1)

- (b) Write down the distance between Norwich and Cambridge.

.....64..... miles
(1)

- (c) Write down the names of the places that are 78 miles apart

.....Norwich... and... Peterborough
(1)

96. An object is placed on a table.
It exerts a force of 22 newtons on the table.

The pressure on the table is 500 newtons/m²

Calculate the area of the crate that is in contact with the table.
Include suitable units.

$$A = \frac{F}{P} \quad \frac{22}{500} = 0.044 \text{ m}^2$$

or
4400cm²

.....4400cm².....
(3)

97.

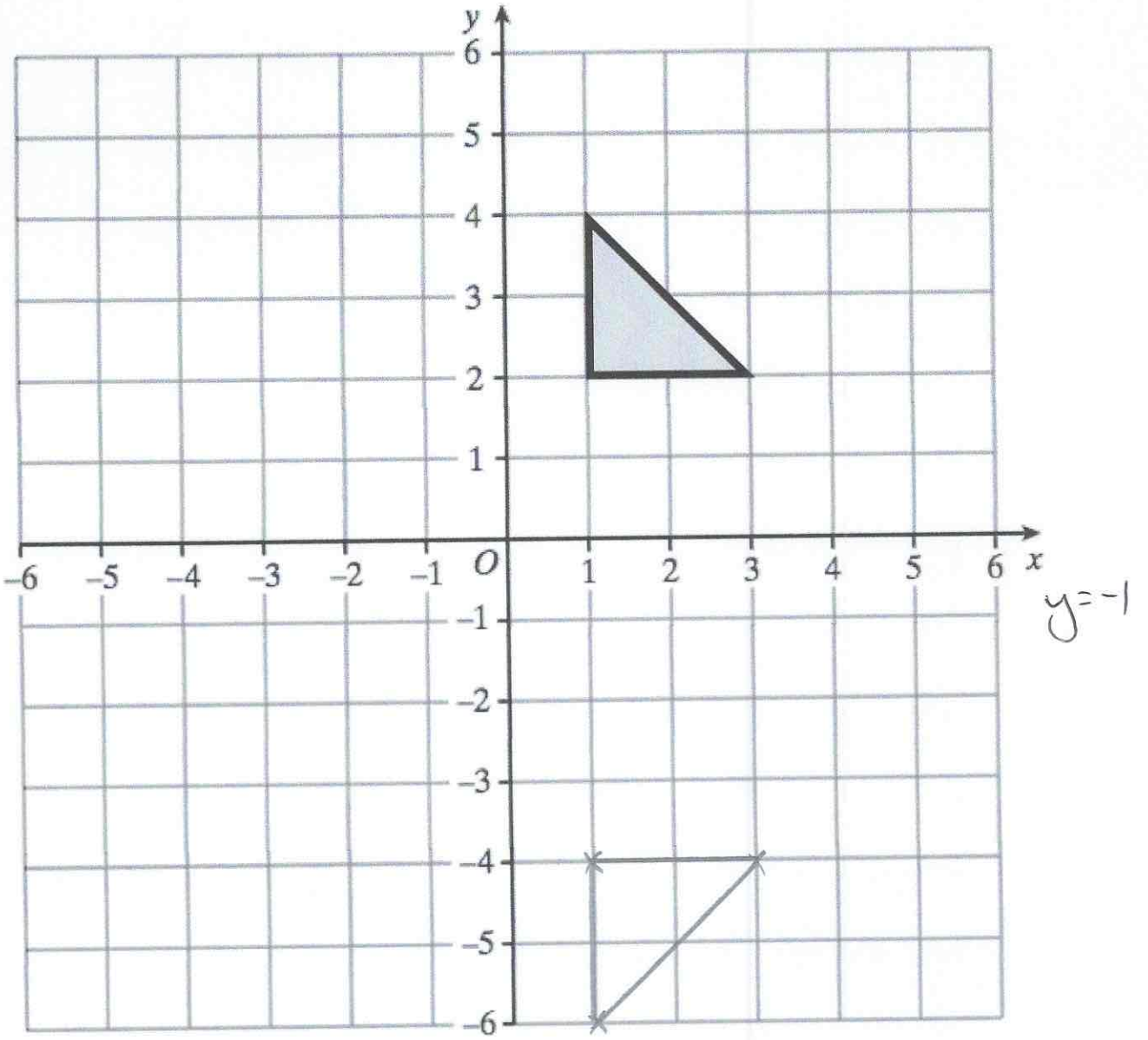

Reflect the triangle in the line $y = -1$
Label the new triangle B.

(2)

98. Shown below are six triangles that are not drawn accurately.

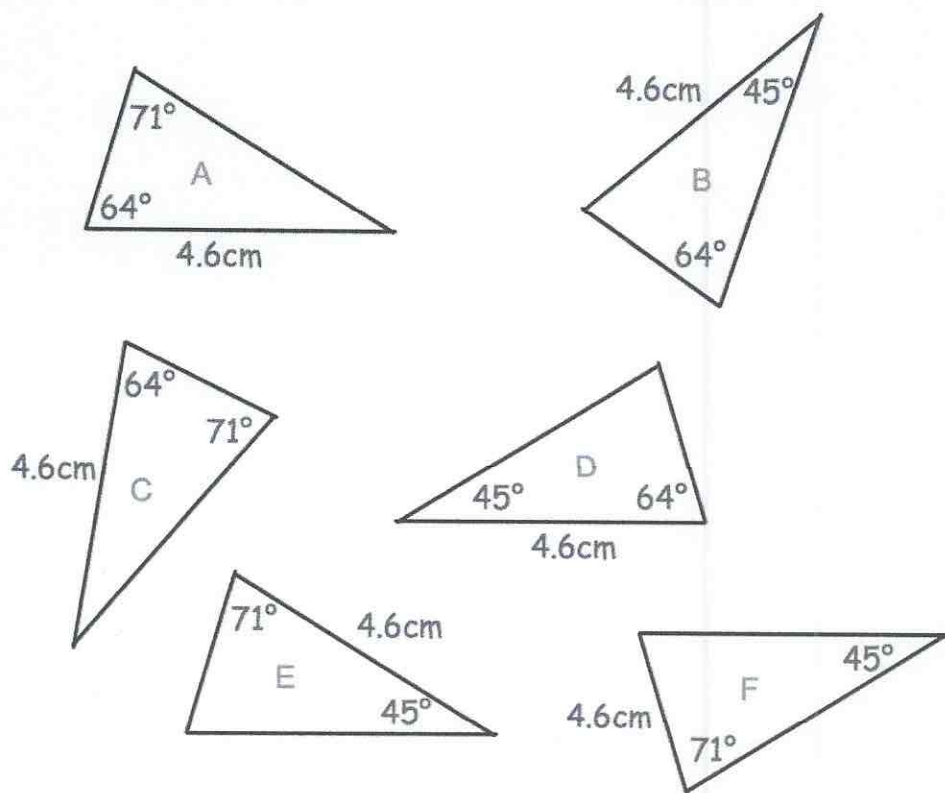

Which two triangles are congruent to triangle A?

.....D..... andC.....
(2)

99. Sophie asks 20 of her friends to choose their favourite sport.

Their replies are

Rugby Football Rugby Hockey Cricket
Football Football Rugby Hockey Football
Rugby Cricket Hockey Football Football
Football Rugby Football Football Rugby

Complete the tally and the frequency columns in the table below.

| Sport | Tally | Frequency |
|----------|-------|-----------|
| Rugby | | 6 |
| Football | | 9 |
| Hockey | | 3 |
| Cricket | | 2 |

(2)

100. Below is a line graph that shows the population of a village.

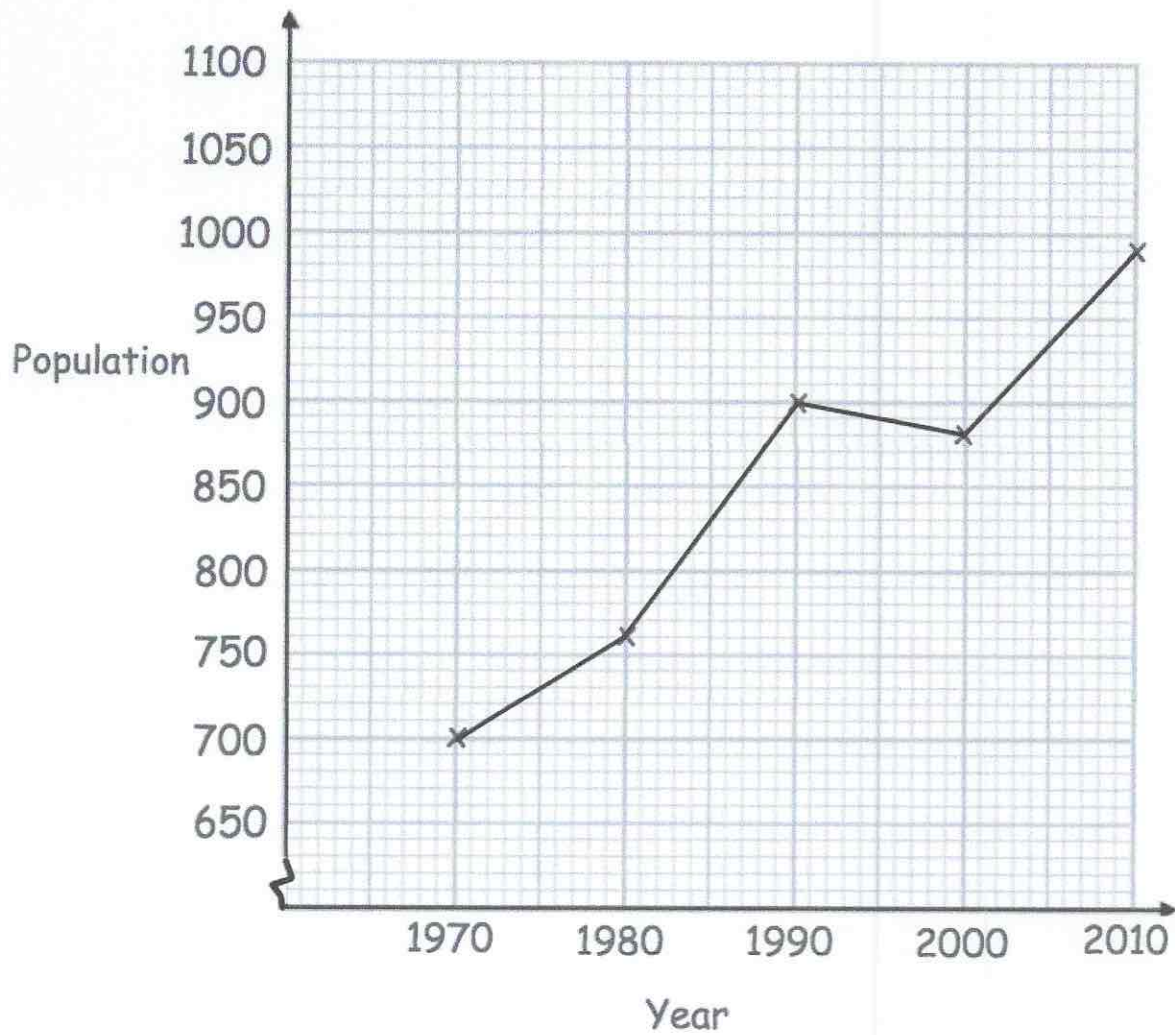

(a) What was the population in 1980?

760
(1)

(b) In which year was the population 700?

1970
(1)

The population increased by 120 by 2020.

(c) Work out the population in 2020.

1110
(2)

101. A three-sided spinner is labelled A, B and C.

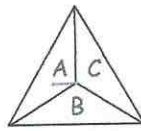

The spinner is spun and the frequency the letter A is recorded every 10 spins. The table below shows this information.

| | | | | |
|-------------------|----|----|----|----|
| Spins | 10 | 20 | 30 | 40 |
| Frequency of an A | 5 | 12 | 21 | 26 |

$$\frac{5}{10} = 0.5 \quad \frac{12}{20} = 0.6 \quad \frac{21}{30} = 0.7 \quad \frac{26}{40} = 0.65$$

(a) Complete plot the relative frequencies on the graph below.

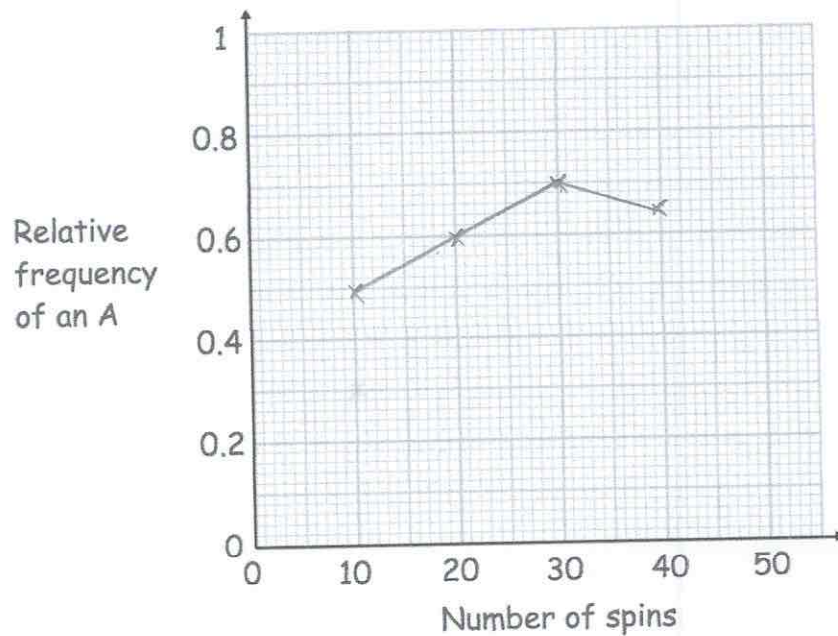

(3)

(b) Neil says the relative frequency after 50 spins is 0.8
Explain why Neil must be wrong

$50 \times 0.8 = 40$, that would mean 14 more A
in 10 spins - not possible

(2)

102. The table shows the number of pages in 100 books.

| Number of pages, x | Frequency |
|----------------------|-----------|
| $0 < x \leq 100$ | 7 |
| $100 < x \leq 200$ | 25 |
| $200 < x \leq 300$ | 40 |
| $300 < x \leq 400$ | 12 |
| $400 < x \leq 500$ | 16 |

Write down the modal class interval.

$$\underline{200 < x \leq 300}$$

(1)

103. A manager recorded how long each customer spent in his supermarket. The table shows his results.

| Time, t (minutes) | Frequency |
|---------------------|-----------|
| $0 < t \leq 10$ | 24 |
| $10 < t \leq 20$ | 31 |
| $20 < t \leq 30$ | 50 |
| $30 < t \leq 40$ | 35 |
| $40 < t \leq 50$ | 60 |

Which class interval contains the median?

$$\frac{200}{2} = 100^{\text{th}}$$

or

$$\frac{201}{2} = 100.5^{\text{th}}$$

$$\underline{20 < t \leq 30}$$

(1)

104.

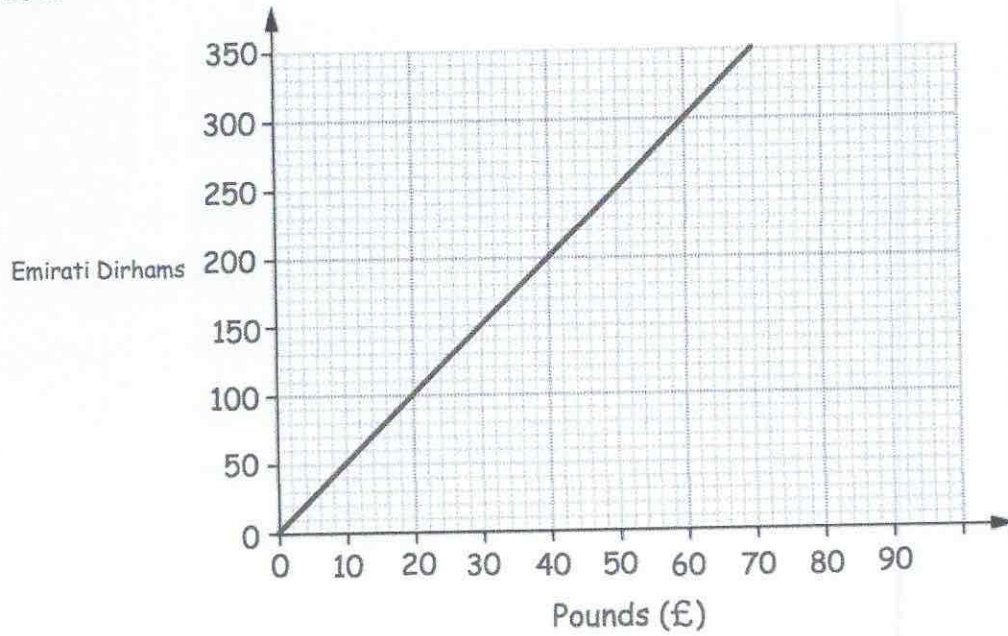

Tom wants to buy a camera.
In London the camera costs £380.
In Abu Dhabi the camera costs 2000 Dirhams.

In which city is the camera cheaper and by how much?
Give your answer in pounds.

$$2000 \text{ dirhams} = \pounds 400$$

City: London... £ 20.....
(1)

105. A is the point with coordinates (1, 4).
B is the point with coordinates (7, 22).

Find the gradient of AB.

$$\frac{18}{6} = 3$$

3

(2)

106. Connor's watch is 17 minutes slow
Joseph's watch is 5 minutes fast
The time on Joseph's watch is 19:01

What time is shown on Connor's watch?



18:39

(1)

107. Here is part of a timetable for a bus.

| | | | |
|------------|-------|-------|-------|
| Southville | 09 18 | 10 38 | 12 05 |
| Leek | 09 28 | 10 48 | ----- |
| Milton | 09 41 | 11 01 | ----- |
| Newtown | 09 49 | 11 09 | ----- |
| Red Island | 09 55 | 11 15 | 12 36 |
| Sandville | 10 13 | 11 33 | ----- |
| Bakerstown | 10 31 | 11 51 | 13 00 |

A bus leaves Southville at 10 38

(a) At what time should the bus arrive at Newtown?

.....11:09.....
(1)

(b) How long will the journey take?

.....31.....minutes
(1)

James arrives at the Milton bus stop at 09 29.
He waits for the next bus to Red Island.

(c) (i) How many minutes should he wait?

.....12.....minutes
(1)

(ii) At what time should James arrive at Red Island?

.....09:55.....
(1)

Sally wants to travel from Southville to Bakerstown.
The 12 05 is an 'express' bus.

(d) How many minutes shorter is the journey if she takes the 'express bus'?

.....18.....minutes
(2)

108. Write down the exact value of $\sin 30^\circ$

$$\frac{1}{2}$$

(1)

109. Express 42 as a percentage of 64

$$\frac{42}{64} = 0.65625$$

$$65.625\%$$

(2)

110. Sarah bought a TV for £250
Three years later she sold it for £180

Work out the percentage loss

$$\frac{70}{250} \times 100$$

$$28\%$$

(3)

111. Florence buys a car for £17100

She pays a deposit of £6750 and pays the rest in equal monthly payments.
Each monthly payment is £230

How many monthly payments does Florence make?

$$17100 - 6750 = 10350$$
$$10350 \div 230 = 45$$

$$45$$

(3)

112. A supermarket sells Baked Beans in two different size cans.



215g
40p



395g
74p

Which size can is the best value for money?
You must show all your working.

$$\begin{aligned} 215\text{g} &= 40\text{p} \\ 1\text{g} &= 0.186\text{p} \end{aligned}$$

$$\begin{aligned} 395\text{g} &= 74\text{p} \\ 1\text{g} &= 0.187\text{p} \end{aligned}$$

The 215g tin is better value

(4)

-
113. 5 Year 10 students and 45 Year 11 students sit a test.

The mean mark for the whole group is 70
The mean mark for the Year 11 students is 72

Work out the mean mark for the Year 10 students.

$$\begin{aligned} 72 \times 45 &= 3240 \\ 50 \times 70 &= 3500 \\ 3500 - 3240 &= 260 \\ 260 \div 5 &= 52 \end{aligned}$$

.....52.....

(2)

-
114. An airplane has economy and first class seating.
There are s seats in each row in economy.
There are t seats in each row in first class.
There are 8 rows in first class and 18 rows in economy.

Write down an expression, in terms of s and t , for the number of seats on the airplane.

..... $18s + 8t$

(2)

115. Here is a pattern of dots

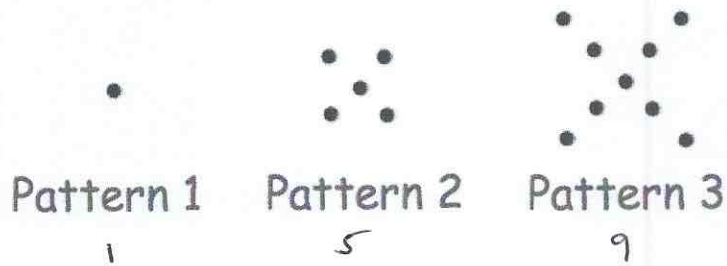

(a) Continue the pattern to show Pattern 4



(2)

(b) How many dots will there be in Pattern 6?

17 21

.....21.....
(1)

(c) Which pattern will use 77 dots?

$$4n - 3 = 77$$

$$4n = 80$$

$$n = 20$$

.....20th.....
(1)

(d) Explain why there will **not** be a pattern that uses 200 dots.

.....All patterns use an odd number.....
.....of dots.....

(1)

116. Circle the geometric progression.

11, 9, 7, 5 ...

1, 4, 9, 16 ...

11, 21, 31, 41 ...

1, 4, 16, 64 ...

(1)

117.

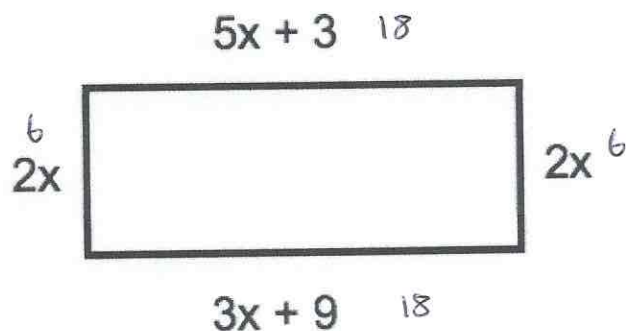

The diagram shows a rectangle. The sides are measured in centimetres.

(a) Explain why $5x + 3 = 3x + 9$

The opposite sides of a rectangle have equal length.

(1)

(b) Solve $5x + 3 = 3x + 9$

$$\begin{aligned}2x + 3 &= 9 \\2x &= 6 \\x &= 3\end{aligned}$$

$$x = 3 \text{ cm}$$

(2)

(c) Calculate the perimeter of the rectangle.

$$6 + 18 + 6 + 18 =$$

$$48 \text{ cm}$$

(2)

118.

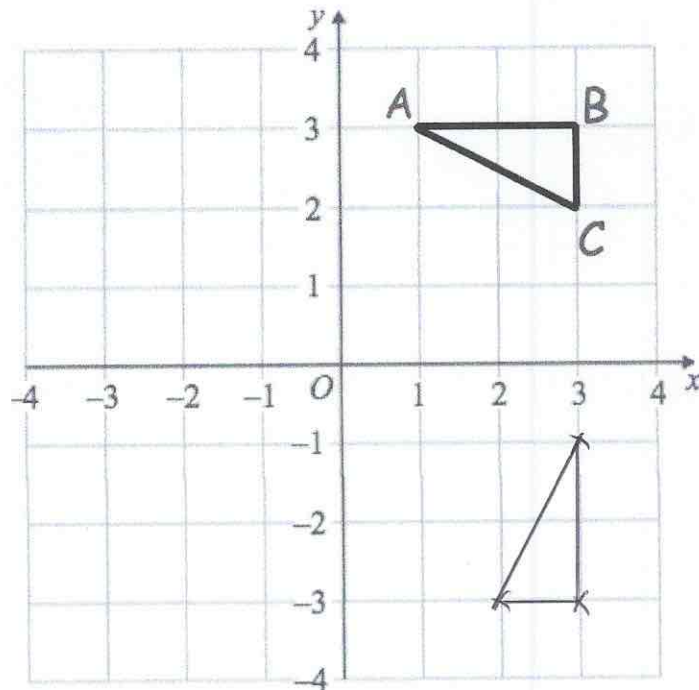

Rotate triangle ABC 90° clockwise about centre (0, 0)

(3)

119. Mr Holland has 2500kg of rice.

- (a) Write 2500 kg in grams.
Give your answer in standard form.

2500000

2.5×10^6 g
(2)

- (b) One grain of rice weighs 0.03g
Write the weight of one grain of rice in standard form.

3×10^{-2} g
(1)

- (c) How many grains of rice are there in 2500kg of rice?
Give your answer in standard form.

$(2.5 \times 10^6) \div (3 \times 10^{-2})$ 8.3×10^7
(2)

120. The number of months, m , to complete a piece of research is found by $m = \frac{600}{n}$

where n is the number of scientists working on the research.

How long should the research take if 12 scientists are working on it?

$$m = \frac{600}{12} \\ = 50$$

.....50 months
(2)

121. 140 students sign up for a college course.

At the end of the course, each student has two attempts to pass a test.

If a student passes either attempt, they are awarded a certificate

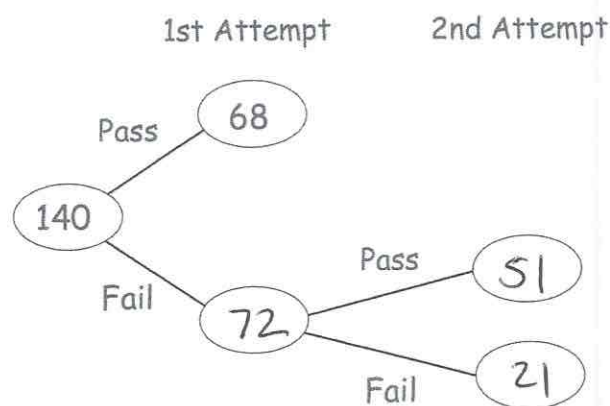

85% of the students receive a certificate.

Work out how many students passed the test in their 2nd attempt.

$$85\% \text{ of } 140 = 119$$

$$119 - 68 = 51$$

(3)

122

The table gives information about students staying after school to play sport.

| Sport | Frequency | Angle |
|----------|-----------|-------------|
| Netball | 15 | 90° |
| Hockey | 10 | 60° |
| Rugby | 26 | 156° |
| Football | 9 | 54° |

60

$$360 \div 60 = 6^\circ$$

Draw an accurate pie chart to show this information.

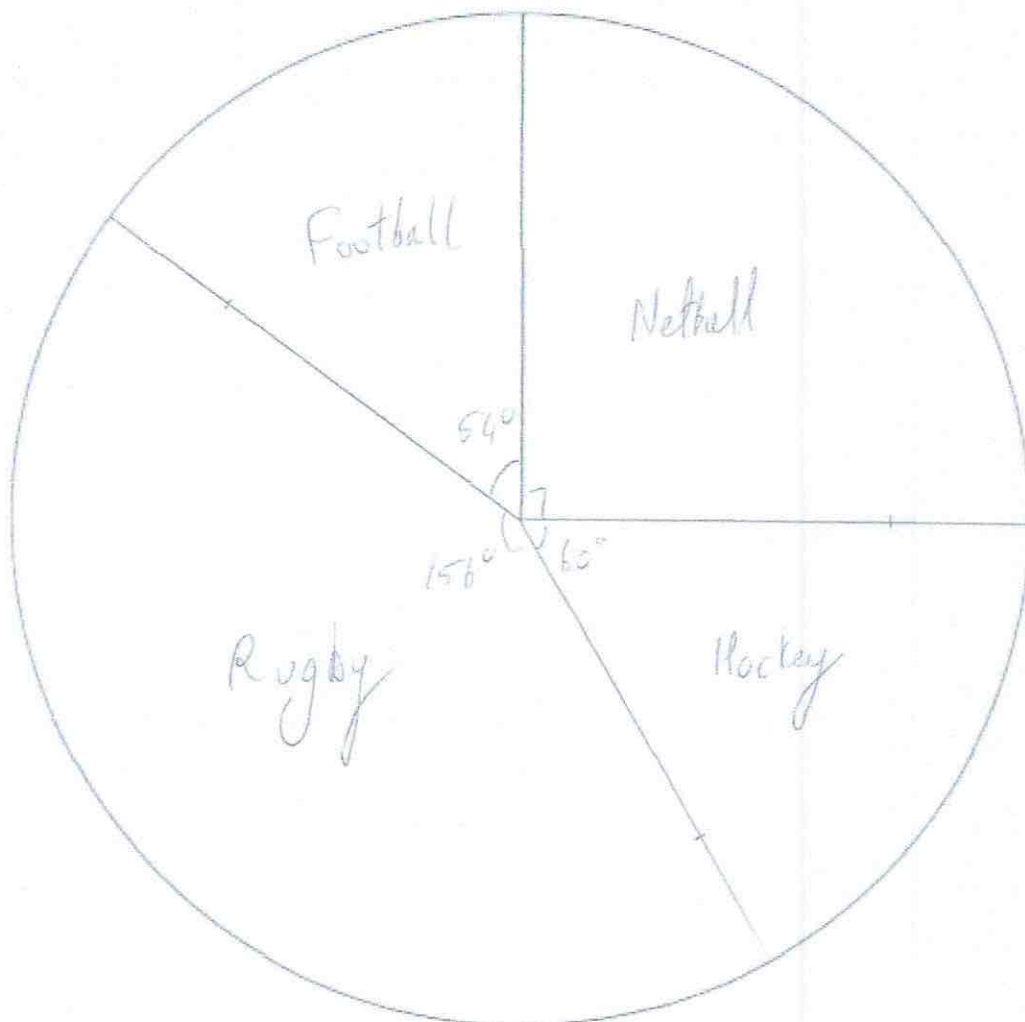

(4)

123. 480 students attend a school.
 A teacher asks 50 students which colour they would like the new school blazer to be.
 The table shows the results.

| Colour | Number of students |
|--------|--------------------|
| Black | 20 |
| Navy | 15 |
| Green | 9 |
| Maroon | 6 |

Estimate how many of the 480 students would like a black blazer.

$$\frac{20}{50} \times 480 = 192$$

.....192.....
 (2)

124.

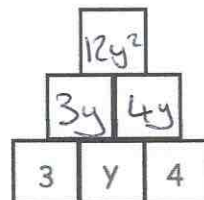

To find the contents of each empty box, multiply the two terms directly beneath it.

Complete the multiplication pyramid.

(3)

125. Expand $w(w - 8)$

$$\underline{w^2 - 8w}$$

(2)

126. Factorise

$$15y + 20$$

$$\underline{5(3y+4)}$$

(2)