

## Paper 2 and Paper 3 Preparation Paper

Edexcel Foundation



Corbettmαths

Ensure you have: Pencil, pen, ruler, protractor, pair of compasses and eraser

You will need a calculator

### Guidance

1. Read each question carefully before you begin answering it.
2. Check your answers seem right.
3. Always show your workings

Paper 2 and 3 Checklist



Question	Topic	Video number
<b>Starred Topics</b>		
1	Angles in a Quadrilateral	33
2	Bearings	26,27,27a,27b
3	Perimeter	241
4	Angle Facts	35,30,34,39
5	Types of Angle	38
6	Measuring/Drawing Angles	31,38
7	Line Symmetry	316
8	Rotational Symmetry	317
9	Constructions	72,78,83
10	Angles in Parallel Lines	25
11	Views & Elevations	354
12	Angles in a Triangle	37
13	Angles in Polygons	32
14	Density	384
15	Pressure	385
16	Translations	325,326
17	Reflections	272,273
18	Rotations	275
19	Enlargements	104,105,107
20	Parts of the Circle	61
21	Circumference	60,243
22	Area of a Circle	59,47
23	Arc Length	58
24	Area of a Sector	46
25	Pythagoras	257
26	Trigonometry	329,330,331
27	Faces, Edges, Vertices	5,3

Question	Topic	Video number
28	Nets	4
29	Volume of a Cylinder	357
30	Volume of a Sphere/Cone	359,361
31	Parallel & Perpendicular Lines	231,232
32	Surface area of a Sphere/Cone	313,314
33	Ordering Decimals	95
34	Prime Numbers	225
35	Time Calculations	322
36	Cube Numbers and Cube Roots	212,214
37	Indices	172
38	Negative Indices	175
39	Fractions of Amounts	137
40	Fractions, Decimals, Percentages	121 to 129
41	Expressing as Fraction or %	136,237
42	Percentages of Amounts	234,235,238
43	Percentage Change	233
44	Simple Interest	236a
45	Compound Interest	236
46	Reverse Percentages	240
47	Ratio	269,270,271
48	Currency	214a
49	Error Intervals	377
50	Money	400
51	Vectors	353a,353
52	Use of a Calculator	352
53	Frequency Trees	376
54	Two-way Tables	319
55	Pictograms	161,162
56	Pie Charts	163,164
57	Listing Outcomes	253

Question	Topic	Video number
58	Similar Shapes (sides)	292
59	Rounding	276,277a,277b,278,280
60	Mode: Frequency Table	56a
61	Median: Frequency Table	51
62	Combined Mean	53a
63	Estimated Mean	55
64	Venn Diagrams	380
65	Tree Diagrams	252
66	Factors	216
67	Product of Primes	223
68	Collecting Like Terms	9
69	Laws of Indices	174
70	LCM/HCF	218,219,224
71	Standard Form	300,302,303
72	Expanding Brackets	13,14
73	Dual/Comparison Bar Charts	148a, 148b
74	Frequency Polygons	155, 156
75	Solving Equations	110,113,,266
76	Forming Equations	114,115
77	Inequalities	177,178,179
78	Stem and Leaf	169, 170
79	Parallel graphs	196
80	Multiplying & Dividing Terms	18,11
81	Changing the Subject	7
82	Simultaneous Equations	295
83	Function Machine	386
84	Writing Expressions	16
85	$y = mx + c$	191
86	Quadratic Graphs	264

Question	Topic	Video number
Other Unseen Topics (or usually more prominent)		
87	Units	347,349
88	Sensible Estimates	285
89	Distance Charts	318
90	Congruent Triangles	67
91	Multiplying Fractions	132
92	Dividing Fractions	134
93	Reciprocals	145
94	Negative Numbers	205 to 209
95	Place Value	222,222a
96	Proportion	255a,254
97	Tally Charts	321
98	Line Graphs	160
99	Probability	245,246,248
100	Relative Frequency	248
101	Conversion Graphs	151
102	Cubic Graphs	344
103	Reciprocal Graphs	346
104	Area of Rectangles/Triangles	45,49
105	Area of Parallelogram/Trapezium	44,48
106	Area of Compound Shapes	41
107	Loci	75,76,77
108	Speed, Distance, Time	299
109	Travel Graphs	171
110	Volume of a Prism	356
111	Square Numbers and Square Roots	226,228
112	Averages & Range	56,50,53,57
113	Samples	281a
114	Sequences	286,287,290,287a
115	Factorising	117

Question	Topic	Video number
116	Factorising Quadratics	118,120
117	Real Life Graphs	171a
118	Substitution	20
119	Timetables	320
120	2D/3D Shapes	1,2,3,327
121	Scales and Maps	283
122	Adding Fractions	133
123	Reading Tables	387
124	Gradient	189
Seen Topics (remember they may still appear, so they may be worthwhile recapping)		
See website	Exact Trig Values	341
See website	Volume of a Cuboid	355
See website	Surface Area	310
See website	Multiplication	199, 200
See website	Division	98
See website	Addition	6
See website	Subtraction	304
See website	Estimation	215
See website	Order of Operations	211
See website	Arithmetic with Decimals	90 to 94
See website	Recipes	256
See website	Best Buys	210
See website	Scatter Graphs	165 to 168
See website	Coordinates	84
See website	nth Term	288
See website	Drawing Linear Graphs	186

1. Shown below is a parallelogram.

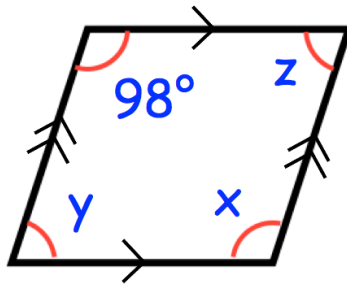

(a) Find x

.....°  
**(1)**

(b) Find y

.....°  
**(1)**

(c) Find z

.....°  
**(1)**

2. This is a map of an island.

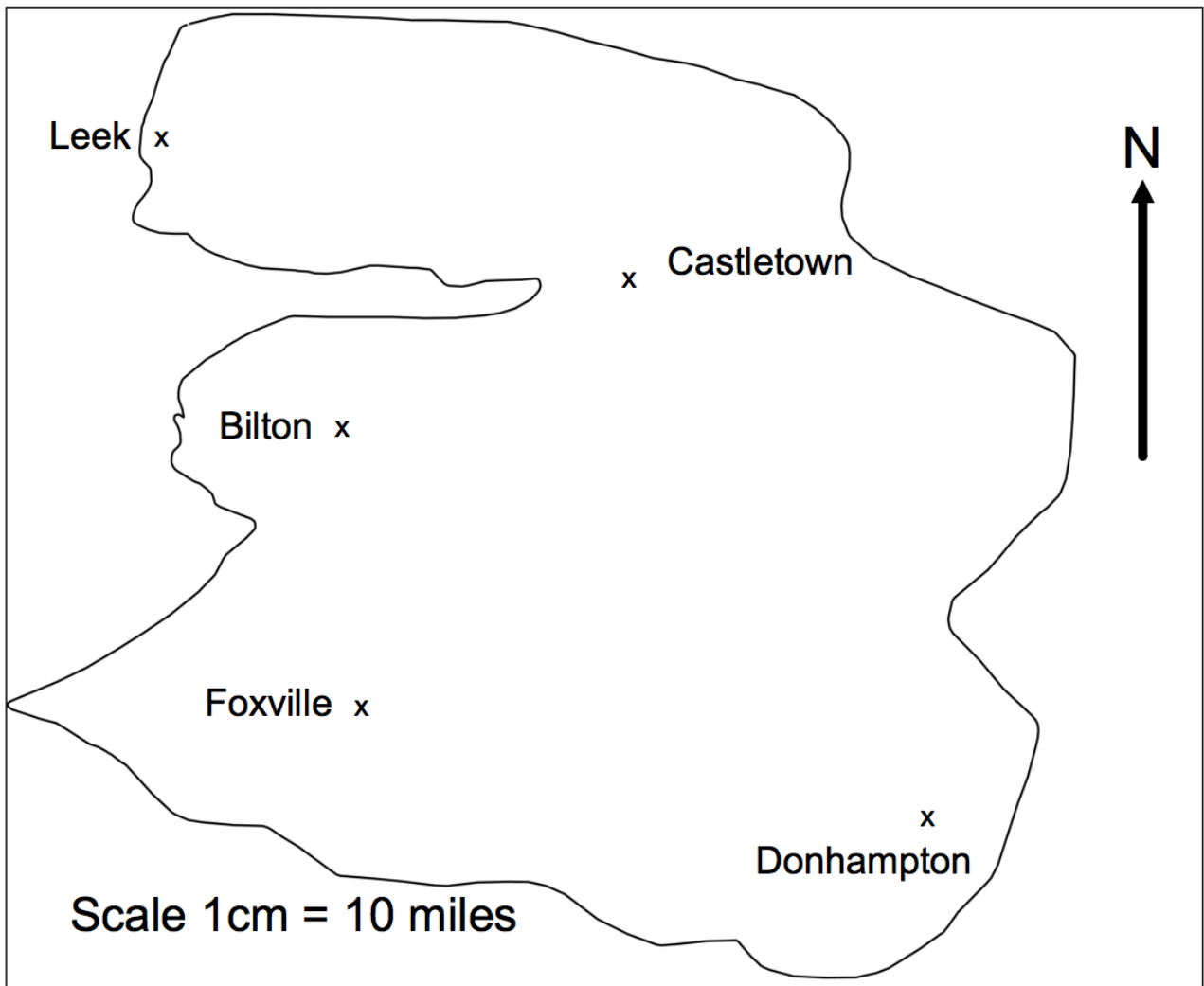

A helicopter flies in a straight line from Leek to Donhampton.

(a) How far does the helicopter fly?

.....miles  
(2)

(b) Write down the bearing of Donhampton from Leek.

.....°  
(1)

3. The perimeter of a parallelogram is 17cm.  
The length of each long side is 5cm.



Work out the length of each short side.

.....cm  
**(2)**

---

- 4.

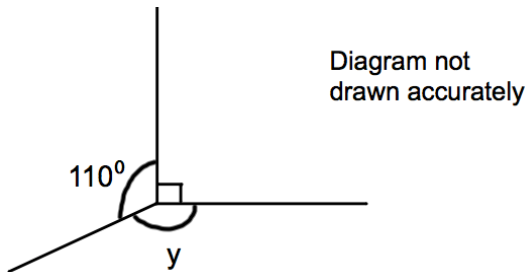

Work out the size of the angle marked y.

.....°  
**(2)**

5.

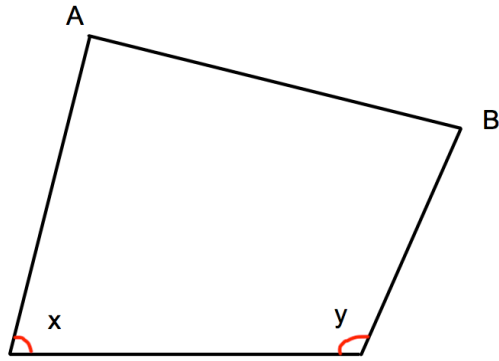

What type of angle is  $x$ ?

.....  
**(1)**

6.

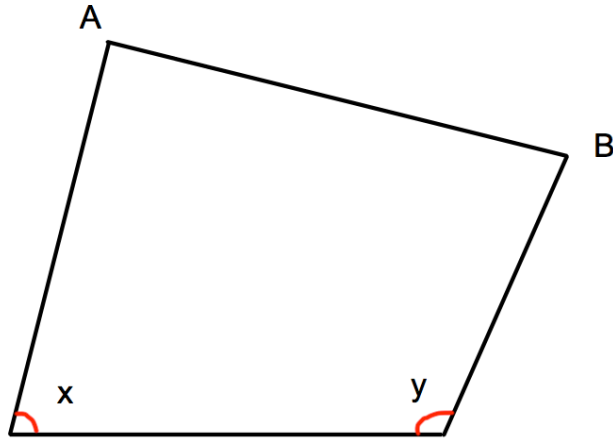

(a) Measure the length of the line AB.

.....cm  
**(1)**

(b) What type of angle is  $x$ ?

.....  
**(1)**

(c) Measure the size of angle  $y$ .

.....°  
**(1)**

7.

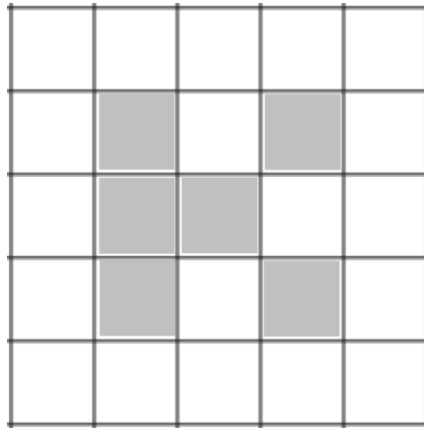

Shade one more square to make a pattern with 1 line of symmetry.

(1)

---

8.

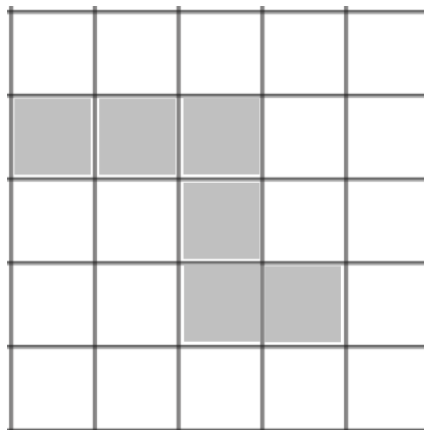

Shade one more square to make a pattern with rotational symmetry order 2.

(1)

9. Use ruler and compasses to construct the perpendicular bisector of AB. You **must** show clearly all your construction arcs.

A .

. B

(2)

10.

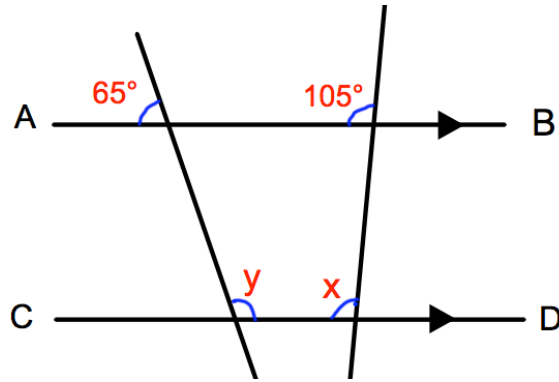

AB is parallel to CD.

(a) Work out the size of the angle marked x.

.....°

Give a reason for your answer.

.....

.....

**(2)**

(b) Work out the size of the angle marked y.

.....°

**(2)**

11. Shown below is a solid shape made from centimetre cubes.

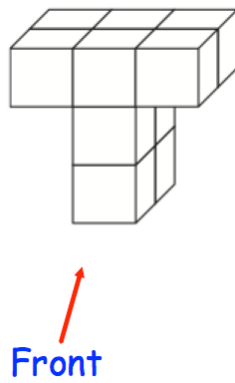

(a) On the centimetre square grid, draw the front elevation.

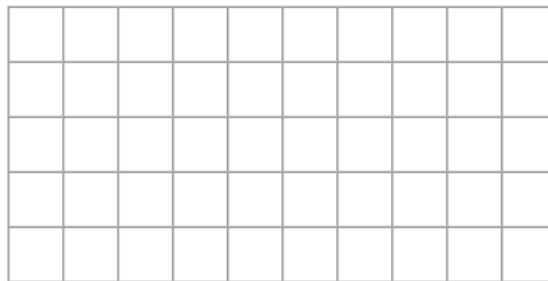

(2)

(b) On the centimetre square grid, draw the plan view.

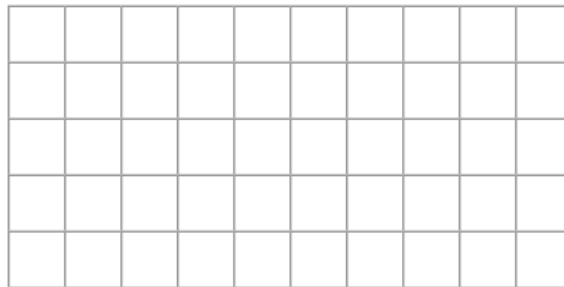

(2)

12.

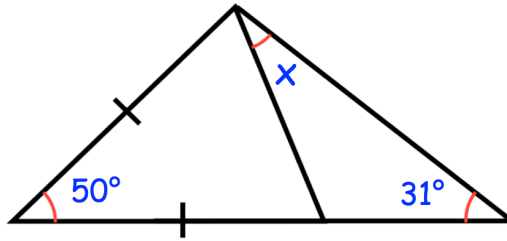

Find the size of the angle marked x.

.....°  
**(4)**

13. Shown is a regular hexagon and a regular octagon.

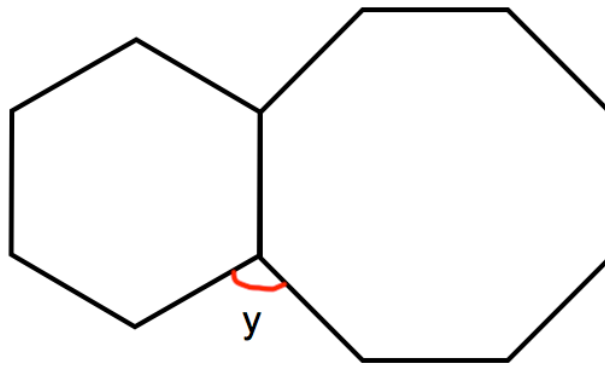

Calculate the size of angle y.

$y = \dots\dots\dots^\circ$   
**(3)**

14. Iron has a density of  $7.8\text{g/cm}^3$ .  
A solid iron statue has a mass of  $877.5\text{g}$ .  
Work out the volume of the statue.

..... $\text{cm}^3$   
**(2)**

---

15. An object is placed on a table.  
It exerts a force of  $22\text{ newtons}$  on the table.

The pressure on the table is  $500\text{ newtons/m}^2$

Calculate the area of the crate that is in contact with the table.  
Include suitable units.

.....  
**(3)**

16.

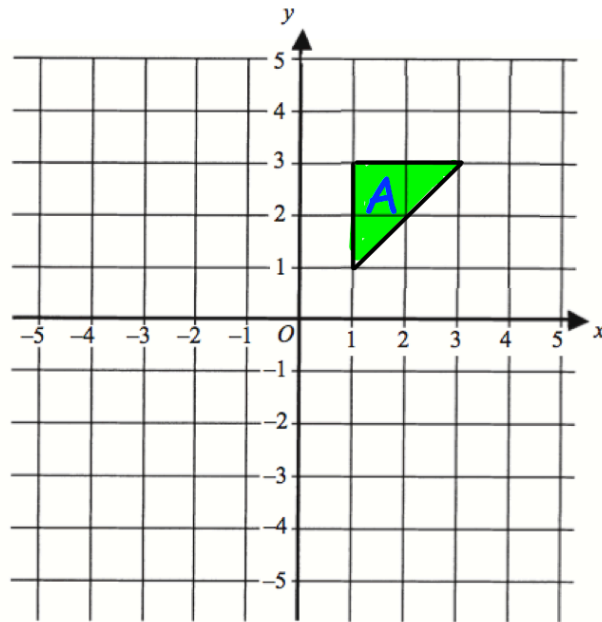

Translate triangle A by the vector  $\begin{pmatrix} -3 \\ 1 \end{pmatrix}$

(2)

17.

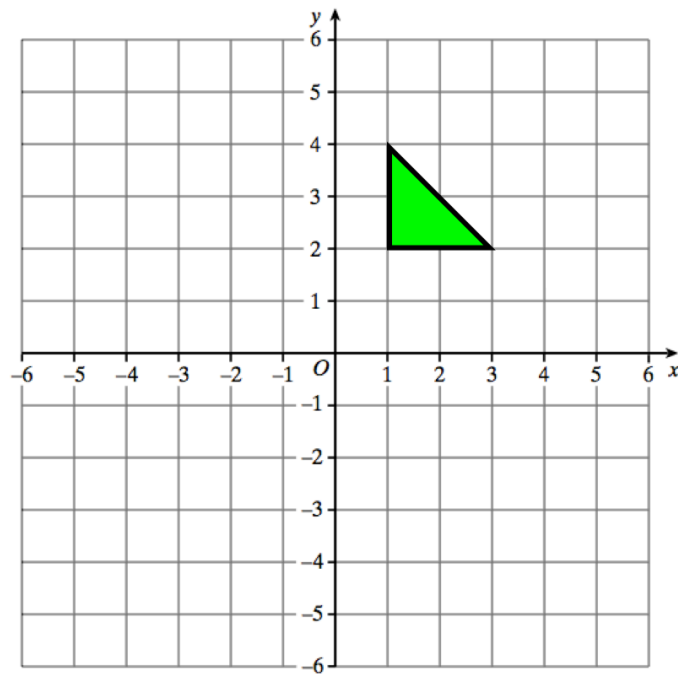

Reflect the triangle in the line  $y = -1$   
Label the new triangle B.

(2)

18.

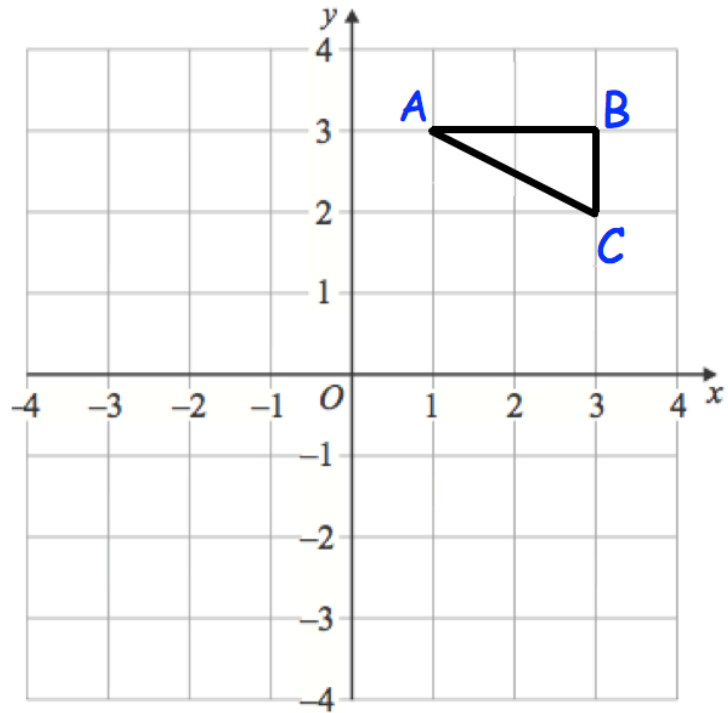

Rotate triangle ABC  $90^\circ$  clockwise about centre (0, 0)

(3)

19.

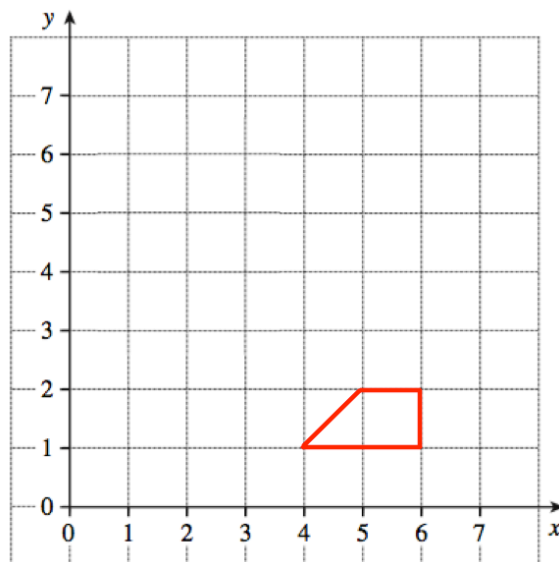





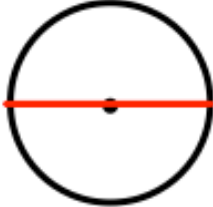

Enlarge the trapezium by scale factor 3, centre (6, 0).

(2)

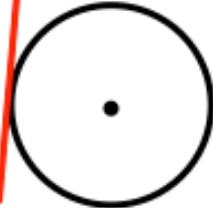
20. Here are 6 diagrams and 6 labels.  
In the diagram the centre of the circle is shown with a dot.

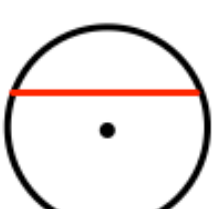
Match each diagram to its label.  
One has been done for you.

Label	Diagram
Circle and radius	
Circle and segment	
Circle and arc	
Circle and diameter	
Circle and tangent	
Circle and chord	

21. A primary school has a running track.  
It has two straights of 50 metres.  
Also there are two 'bends' that are semicircles with diameter 30 metres.

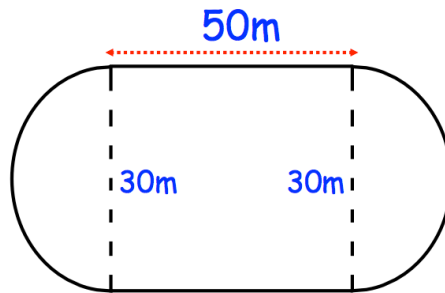

Work out the distance around the running track.

.....m  
(5)

22. The diagram shows a rectangle with a circle cut out.

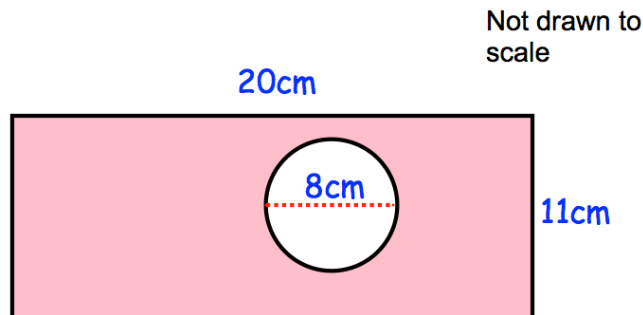

The rectangle has length 20cm and width 11cm.  
The circle has diameter 8cm.

Work out the shaded area.  
Give your answer correct to 2 decimal places.

.....cm<sup>2</sup>  
(4)

23.

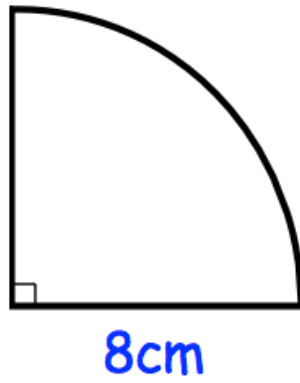

Calculate the perimeter of the sector.

.....cm  
(2)

---

24.

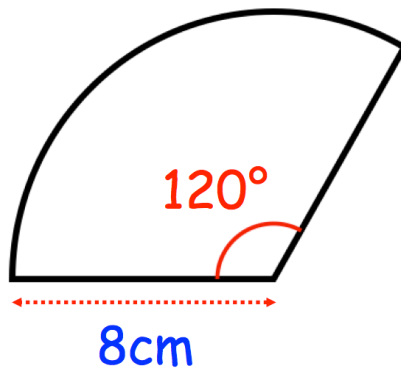

Calculate the area of the sector.

.....cm<sup>2</sup>  
(2)

25.

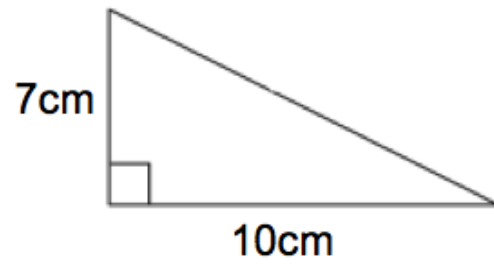

Shown is a right-angled triangle.

Work out the perimeter of the triangle

..... cm  
(4)

26. Triangle ABC has a right angle.  
Angle BAC is  $25^\circ$   
AC = 12.5cm

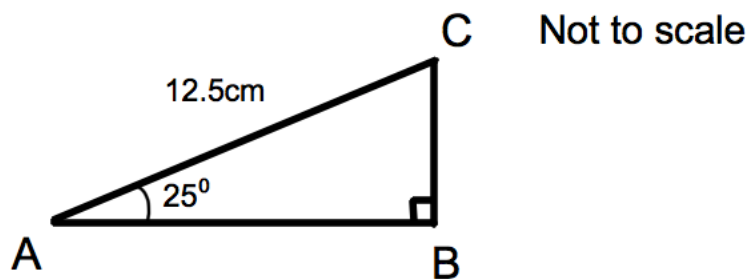

Calculate the length of AB

.....cm  
(3)

27. Below is a solid shape.

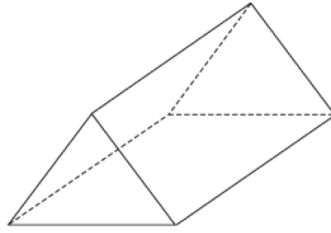

(a) What is the mathematical name for the shape?

.....  
**(1)**

(b) Write down the number of vertices

.....  
**(1)**

(c) Write down the number of faces

.....  
**(1)**

(d) Write down the number of edges

.....  
**(1)**

---

28. Below are the nets of two solid shapes.

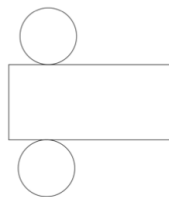

**A**

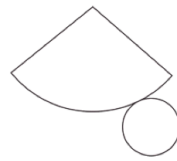

**B**

(a) Write down the shape that is made from Net A.

.....  
**(1)**

(b) Write down the shape that is made from Net B.

.....  
**(1)**

29. Below is a cylinder with radius 2cm and height 5cm.

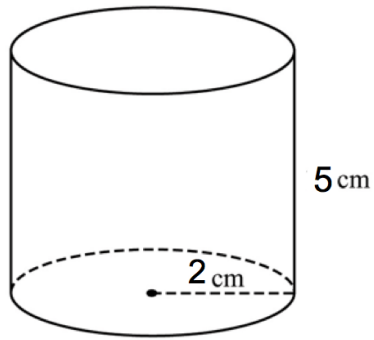

Calculate the volume of the cylinder.

.....cm<sup>3</sup>  
**(3)**

---

30. A cone has base radius 5cm and perpendicular height 9cm.

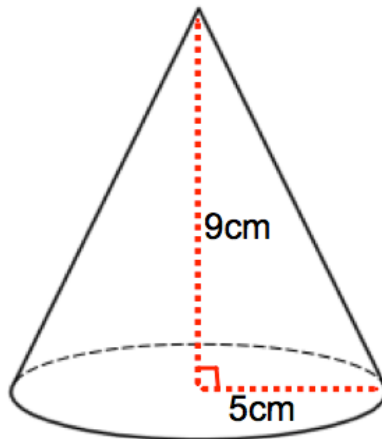

Work out the volume of the cone.

.....cm<sup>3</sup>  
**(3)**

31.

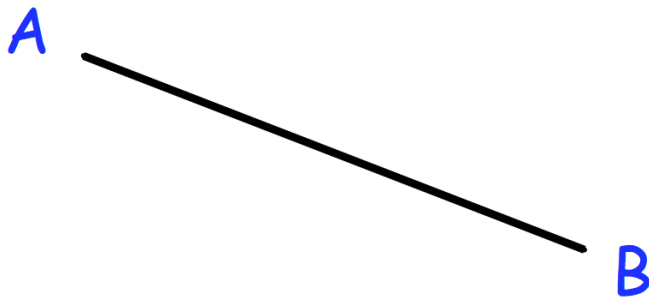

Draw a line perpendicular to the line AB.

.....  
(1)

---

32. A sphere has a radius of 5cm.

Calculate the surface area of the sphere.

.....  
(3)

---

33. Write the following numbers in order of size.  
Start with the largest number.

0.7            0.09            0.269            0.47            0.9

.....  
(1)

---

34. Write down all the prime numbers between 10 and 20.

.....  
(2)

35. Connor's watch is 17 minutes slow  
Joseph's watch is 5 minutes fast  
The time on Joseph's watch is 19:01

What time is shown on Connor's watch?

.....  
(1)

---

36. From the list of numbers

3    6    8    14    16    28    41    64

(a) write down the cube numbers

..... and .....

(2)

(b) write down the cube root of 27.

.....  
(1)

---

37. Calculate  $3^6$

.....  
(1)

---

38. Work out

$$10^{-2}$$

Give your answer as a decimal.

.....  
(2)

39. The attendance at Frome United versus Trowbridge Rovers was 8,701.

Of this crowd, five-sevenths supported Frome United.

Calculate how many people did not support Frome United.

.....  
**(3)**

---

40. Complete the table.

Fraction	Decimal	Percentage
		85%
	0.12	
$\frac{23}{25}$		

**(4)**

---

41. Express 42 as a percentage of 64

.....%  
**(2)**

42. Joanne sees this special offer in a shop.

**Special Offer**

Laptop	£465
Printer	£109

**Buy both items and receive a 4% discount**

Joanne buys both items.

How much does she pay?

£.....  
**(3)**

---

43. Sarah bought a TV for £250  
Three years later she sold it for £180

Work out the percentage loss

.....%  
**(3)**

---

44. Nina invested £1500 for 4 years at 2.5% per annum simple interest.

Work out the total amount of money in the account at the end of 4 years.

£.....  
**(3)**

45. Fiona leaves £1600 in the bank for four years.  
It earns compound interest of 4% each year.

Calculate the total amount Fiona has in the bank at the end of the four years.

£.....  
**(3)**

---

46. Lauren is given a 12% pay rise.  
Her new salary is £24,080

What was Lauren's salary before the pay rise?

£.....  
**(3)**

---

47. Chris and Molly win money in a competition.  
They share the money in the ratio 2 : 3  
Molly receives £240.

(a) How much money does Chris receive?

£.....  
**(2)**

(b) How much money did they win in the competition?

£.....  
**(1)**

48. Sophie went to Spain.  
She changed £225 into euros (€).

The exchange rate was £1 = €1.62

(a) Change £225 into euros (€).

€.....  
**(2)**

On her return to England, Sophie changed €66 into pounds (£)

The new exchange rate was £1 = €1.50

(b) Change €66 into pounds (£).

£.....  
**(2)**

---

49. A number,  $n$ , is rounded to 1 decimal place.  
The result is 1.3

Using inequalities, write down the error interval for  $n$ .

.....  
**(2)**

50. Florence buys a car for £17100

She pays a deposit of £6750 and pays the rest in equal monthly payments.  
Each monthly payment is £230

How many monthly payments does Florence make?

.....  
(3)

51. OCPL is formed from nine congruent parallelogram

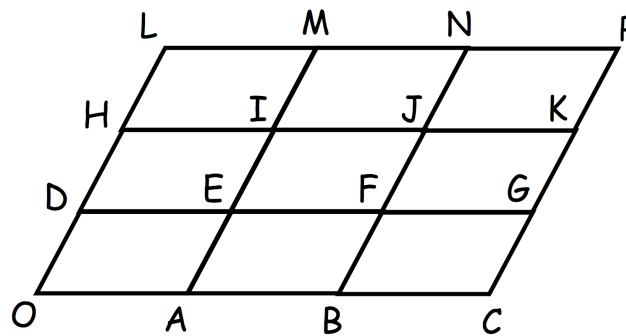

$$\vec{OA} = \mathbf{a} \quad \vec{OD} = \mathbf{b}$$

Write the vector  $\vec{OG}$  in terms of  $\mathbf{a}$  and  $\mathbf{b}$ .

.....  
(1)

52. Work out

$$\sqrt[4]{100 - 2.4^3}$$

Give your answer to 3 significant figures.

.....  
(2)

53. 140 students sign up for a college course.  
At the end of the course, each student has two attempts to pass a test.  
If a student passes either attempt, they are awarded a certificate

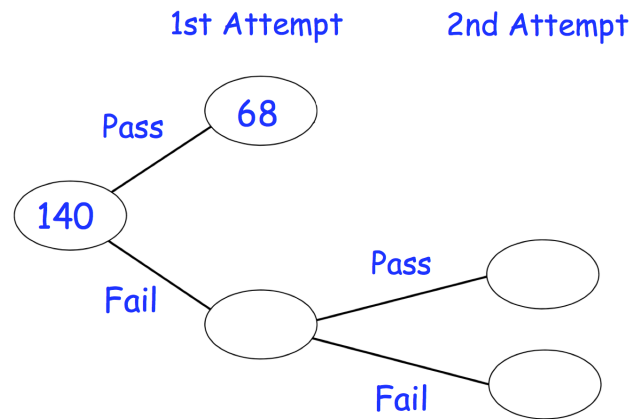

85% of the students receive a certificate.

Work out how many students passed the test in their 2nd attempt.

(3)

54. 100 students study one language at a college.

Some students study French.

Some students study Spanish.

The rest of the students study German.

54 of the students are in Year 12.

20 of the 29 students who study Spanish are in Year 13.

31 students study German.

15 Year 13 students study French.

Work out the number of Year 12 students who study German.

55. The pictogram shows the amount of money raised by students in some tutor groups at a school.

Key ○ = £10

Tutor group		Raised
S	○ ○ ○ ○ ○ ○	
T	○ ○ ○	
E		£45
P	○ ○ ○ ◐	

- (a) Complete the raised column.

(2)

- (b) Complete the pictogram for tutor group E.

(2)

- (c) How much money was raised altogether?

£.....  
(1)

56. The table gives information about students staying after school to play sport.

Sport	Frequency
Netball	15
Hockey	10
Rugby	26
Football	9

Draw an accurate pie chart to show this information.

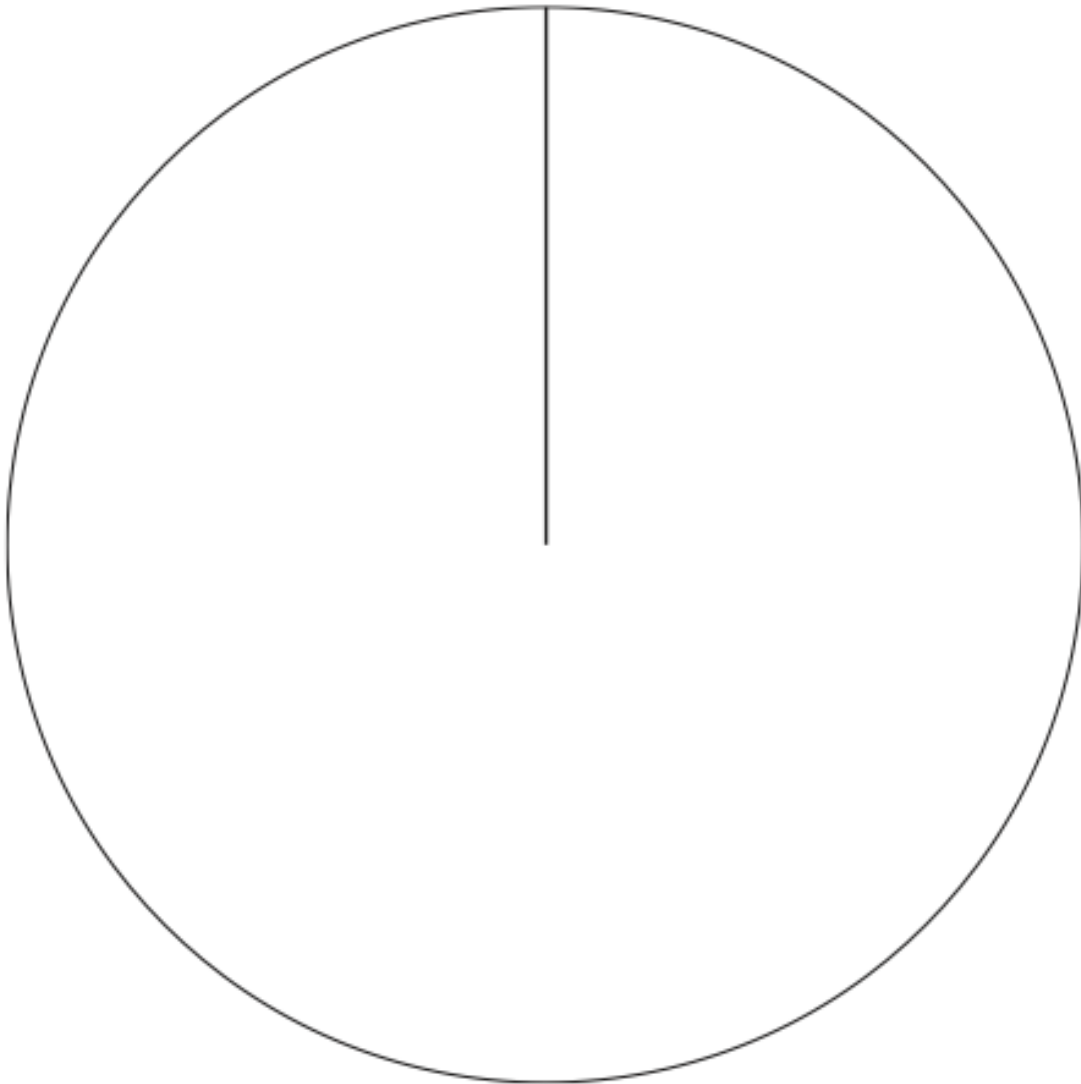

57. William is going to attend a two day summer camp at his local leisure centre. He can take part in one activity on Monday and one activity on Tuesday.

Monday	Tuesday
Golf	Ice-skating
Football	Swimming
Rugby	Dodgeball
Hockey	Basketball

List all the possible combinations of activity he can take part in.

.....

.....

.....

(2)

- 58.

Not drawn accurately

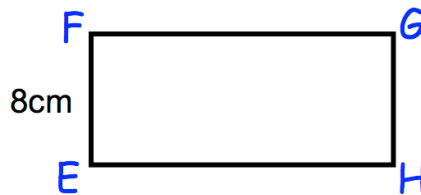
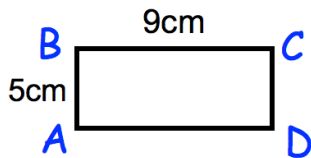

Rectangles  $ABCD$  and  $EFGH$  are similar.

$AB = 5\text{cm}$

$BC = 9\text{cm}$

$EF = 8\text{cm}$

Work out the length of  $FG$ .

.....cm

(2)

59. Holly works out the answer to  $135.66 + 193.88$  on a calculator.

Her answer is 329.54

(a) Round her answer to the nearest 10.

.....  
**(1)**

(b) Round her answer to the nearest 100.

.....  
**(1)**

(c) Round her answer to the nearest integer.

.....  
**(1)**

(d) Round her answer to one decimal place.

.....  
**(1)**

---

60. The table shows the number of pages in 100 books.

Number of pages, $x$	Frequency
$0 < x \leq 100$	7
$100 < x \leq 200$	25
$200 < x \leq 300$	40
$300 < x \leq 400$	12
$400 < x \leq 500$	16

Write down the modal class interval.

.....  
**(1)**

61. A manager recorded how long each customer spent in his supermarket. The table shows his results.

Time, $t$ (minutes)	Frequency
$0 < t \leq 10$	24
$10 < t \leq 20$	31
$20 < t \leq 30$	50
$30 < t \leq 40$	35
$40 < t \leq 50$	60

Which class interval contains the median?

.....  
(1)

---

62. 5 Year 10 students and 45 Year 11 students sit a test.

The mean mark for the whole group is 70

The mean mark for the Year 11 students is 72

Work out the mean mark for the Year 10 students.

.....  
(2)

63. Timothy asked 30 people how long it takes them to get to school. The table shows some information about his results.

Time (t minutes)	Frequency
$0 < t \leq 10$	2
$10 < t \leq 20$	8
$20 < t \leq 30$	12
$30 < t \leq 40$	7
$40 < t \leq 50$	1

Work out an estimate for the mean time taken.

.....minutes  
(4)

64.  $\xi = \{1, 2, 3, 4, 5, 6, 7, 8, 9, 10, 11, 12, 13, 14, 15, 16\}$

A = multiples of 3

B = multiples of 5

- (a) Complete the Venn diagram

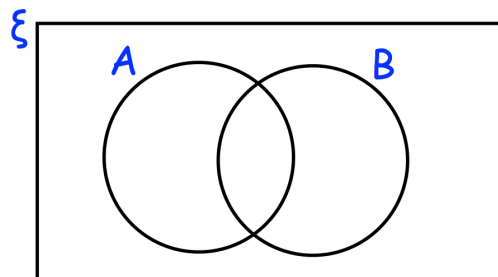

(3)

One of the numbers is selected at random.

- (b) Write down  $P(A \cap B)$

.....  
(1)



66. Write down all the factors of 36.

.....  
(2)

---

67. (a) Write 50 as a product of its prime factors.

.....  
(2)

(b) Find the Lowest Common Multiple (LCM) of 32 and 50.

.....  
(2)

---

68. Simplify  $9h + 5k + 4h - 8k$

.....  
(2)

69. (a) Simplify

$$m^9 \times m^2$$

.....  
**(1)**

(b) Simplify

$$\frac{m^{10}}{m^2}$$

.....  
**(1)**

(c) Simplify

$$(m^3)^6$$

.....  
**(1)**

---

70. Tilly the dog barks every 9 seconds.  
Billy the dog barks every 12 seconds.  
They both bark at the same time.

After how many seconds will they next bark at the same time?

.....seconds  
**(2)**

71. Mr Holland has 2500kg of rice.

- (a) Write 2500 kg in grams.  
Give your answer in standard form.

.....g  
**(2)**

- (b) One grain of rice weighs 0.03g  
Write the weight of one grain of rice in standard form.

.....g  
**(1)**

- (c) How many grains of rice are there in 2500kg of rice?  
Give your answer in standard form.

.....  
**(2)**

---

72. Expand and simplify  $(w - 3)(w - 8)$

.....  
**(2)**

73.

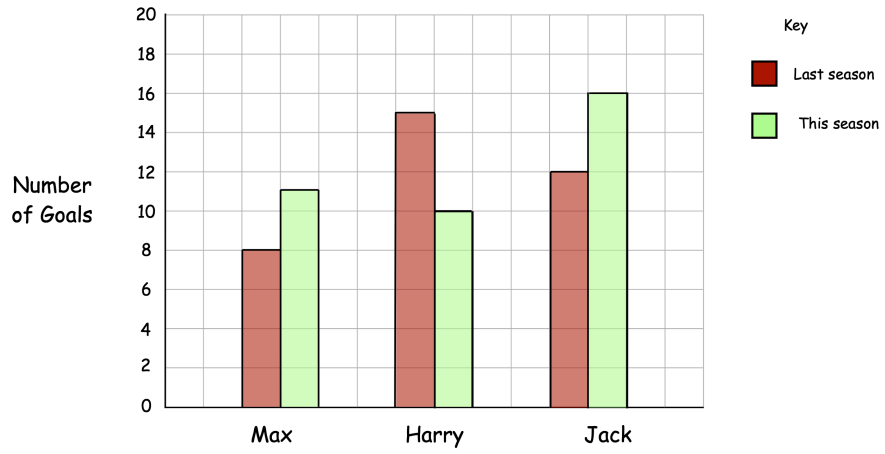

How many fewer goals has Harry scored this season than last season?

.....  
(2)

74. The table gives information about the time taken, in seconds, for students to complete a puzzle.

Time (seconds)	Frequency
$0 < t \leq 10$	7
$10 < t \leq 20$	25
$20 < t \leq 30$	38
$30 < t \leq 40$	16
$40 < t \leq 50$	12

Draw a frequency polygon for the information in the table.

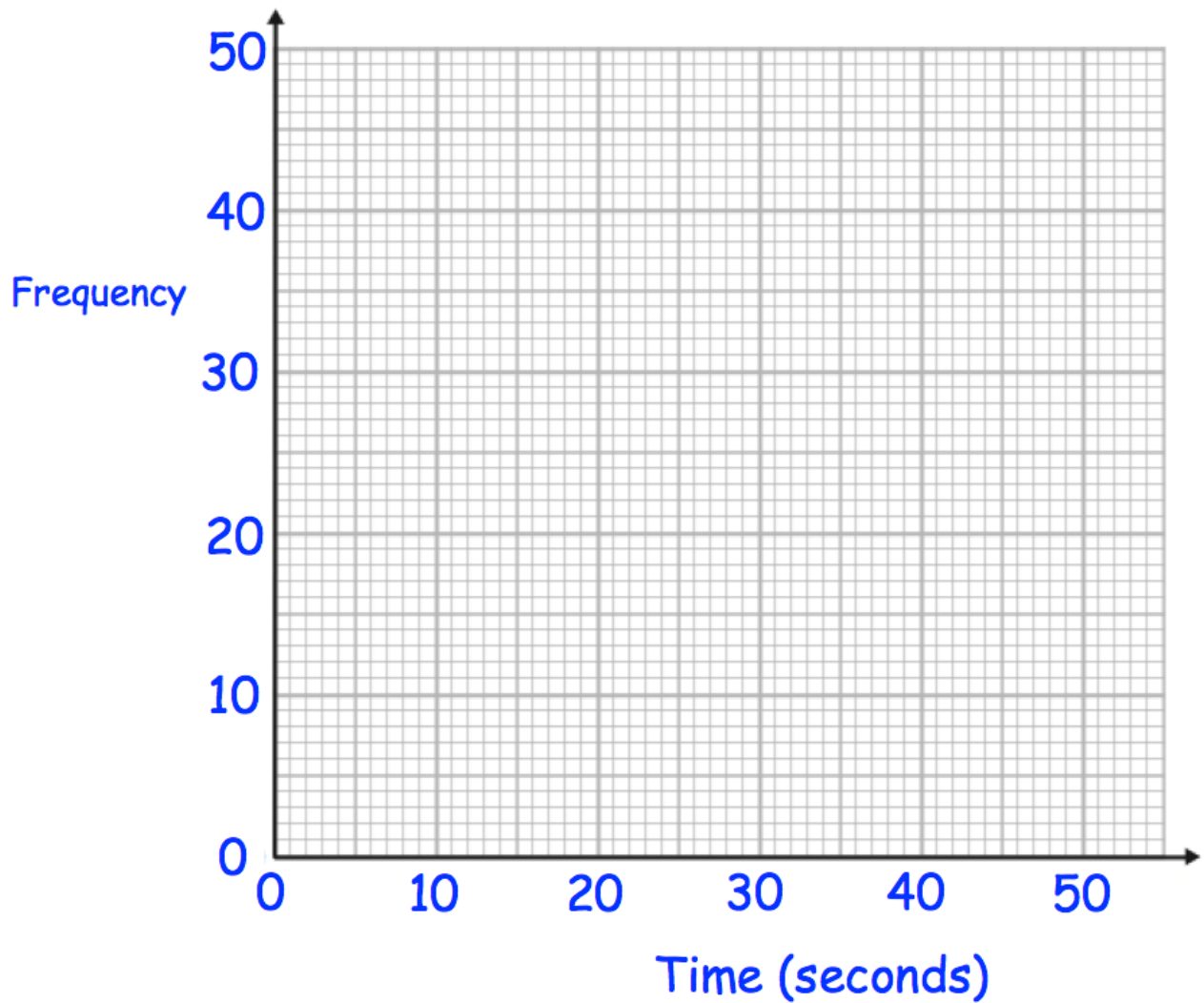

75. Solve  $4y + 1 = 6y + 26$

$y = \dots\dots\dots$   
(2)

---

76.

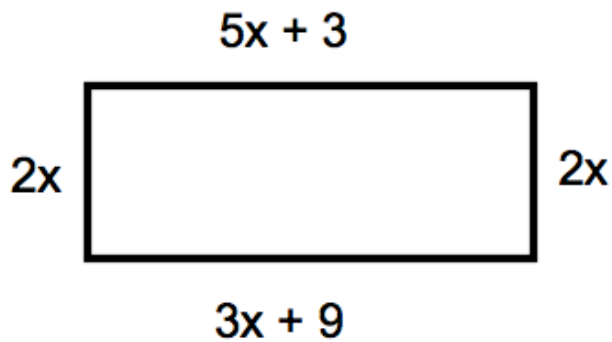

The diagram shows a rectangle. The sides are measured in centimetres.

(a) Explain why  $5x + 3 = 3x + 9$

.....  
.....  
(1)

(b) Solve  $5x + 3 = 3x + 9$

$x = \dots\dots\dots$ cm  
(2)

(c) Calculate the perimeter of the rectangle.

.....cm  
(2)

77. Solve the inequality  $5x + 11 \geq 2$

.....  
(2)

---

78. The stem and leaf diagram shows information about the ratings of 11 footballers in a computer game.

Key:  $6|8$  means 68

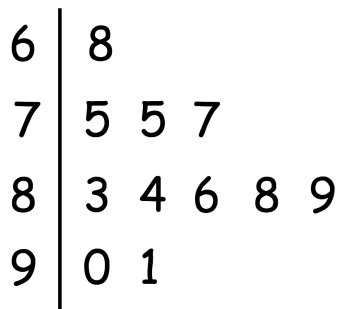

(a) How many of the footballers had a rating less than 85?

.....  
(1)

(b) Write down the mode.

.....  
(1)

(c) Work out the range of the ratings.

.....  
(1)

(d) Work out the median rating.

.....  
(1)

79.

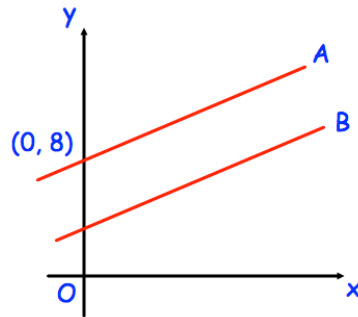

The lines A and B are parallel.  
The line A passes through the point (0, 8)  
The line B has equation  $y = 3x + 4$

Write down the equation of line A

.....  
(2)

80.

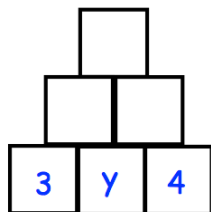

To find the contents of each empty box, multiply the two terms directly beneath it.

Complete the multiplication pyramid.

(3)

81. Make  $w$  the subject of the formula

$$y = 3w - a$$

$w = \dots\dots\dots$

(2)

82. Solve the simultaneous equations

$$2x + 4y = 26$$

$$3x - y = 4$$

Do not use trial and improvement

$$x = \dots\dots\dots y = \dots\dots\dots$$

**(3)**

83.

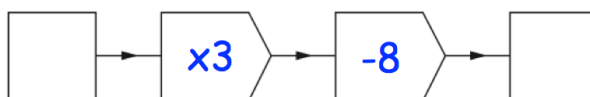

(a) Work out the output, when the input is 10.

.....  
**(1)**

(b) Work out the input, when the output is 13.

.....  
**(1)**

(c) If the input is the same as the output, work out the input.

.....  
**(1)**

84. An airplane has economy and first class seating.  
There are  $s$  seats in each row in economy.  
There are  $t$  seats in each row in first class.  
There are 8 rows in first class and 18 rows in economy.

Write down an expression, in terms of  $s$  and  $t$ , for the number of seats on the airplane.

.....  
(2)

---

85. A straight line L is shown on the grid.

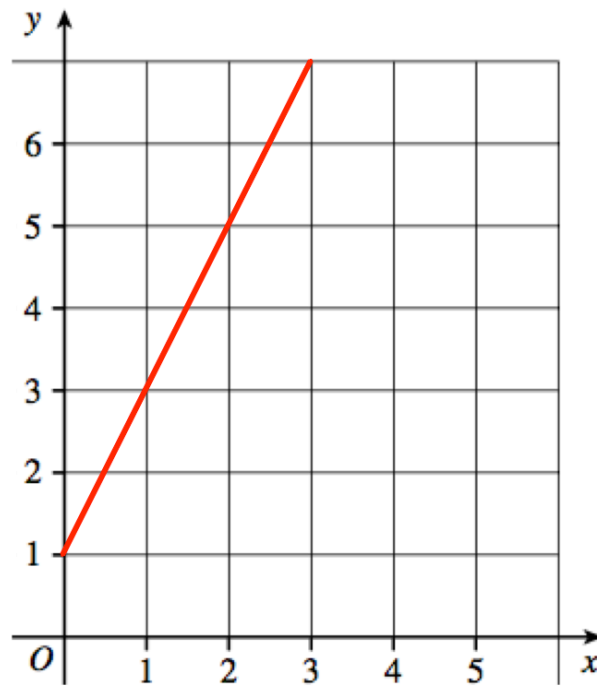

Work out the equation of line L

.....  
(3)

86. (a) Complete the table of values for  $y = x^2 - 3x$

$x$	-2	-1	0	1	2	3	4
$y$	10		0	-2		0	

(2)

(b) On the grid, draw the graph of  $y = x^2 - 3x$  for the values of  $x$  from -2 to 4.

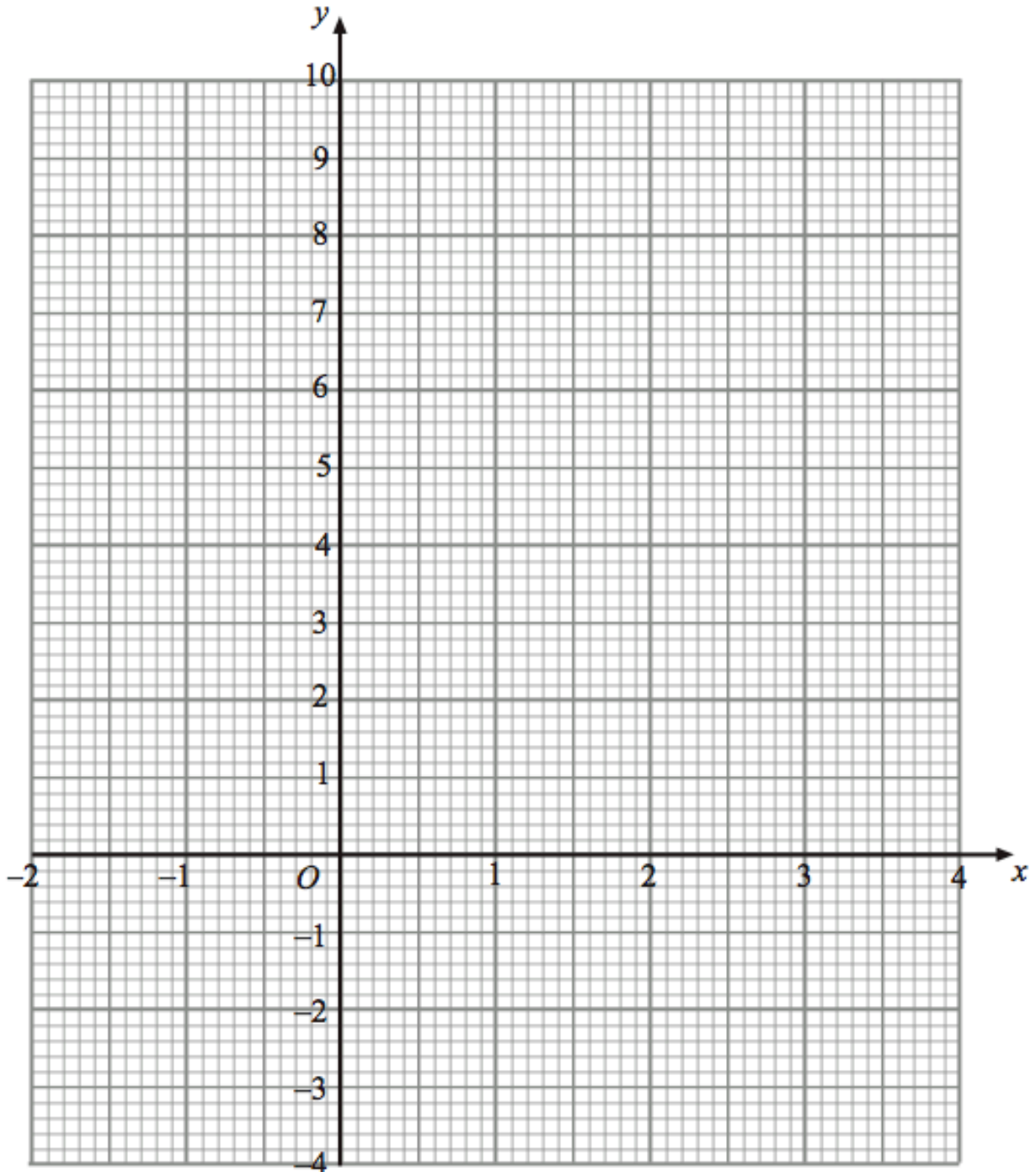

(2)

87. The mass of a 2p coin is 7g.

Find the mass of £6 worth of 2p coins.  
Give your answer in kilograms.

.....kilograms  
**(4)**

---

88. A glass contains water.

Below are four estimates of the amount of water in the glass.  
Circle the most appropriate estimate.

25ml      25L      250ml      2.5L

**(1)**

---

89. The distance chart below shows the distance, in miles, between some towns and cities.

Cambridge			
54	Ipswich		
64	45	Norwich	
43	82	78	Peterborough

(a) Write down the distance between Ipswich and Peterborough.

..... miles  
**(1)**

(b) Write down the distance between Norwich and Cambridge.

..... miles  
**(1)**

(c) Write down the names of the places that are 78 miles apart

..... and.....  
**(1)**

90. Shown below are six triangles that are not drawn accurately.

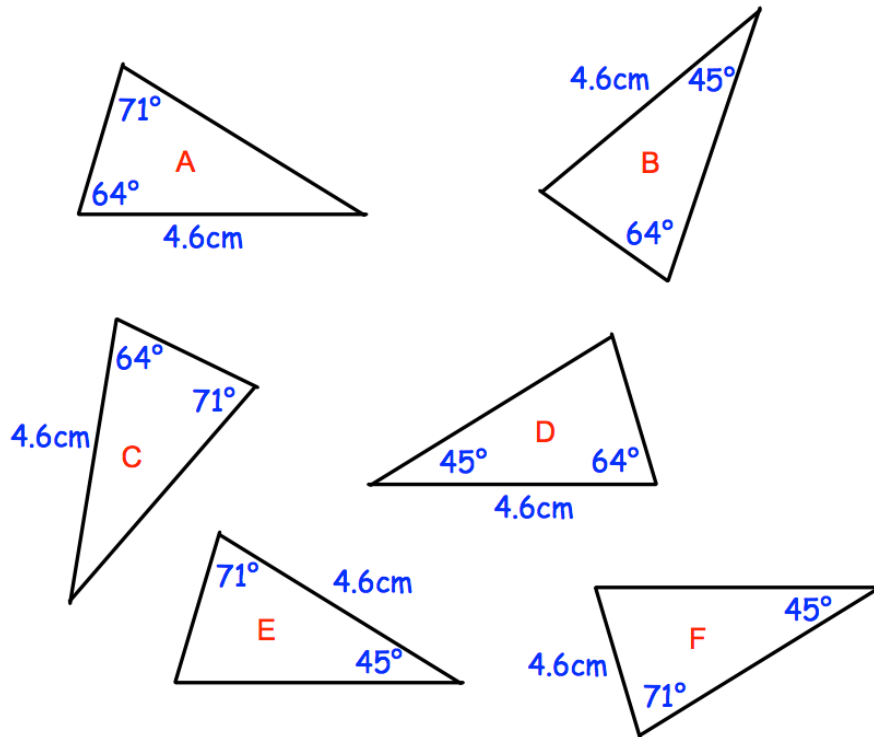

Which two triangles are congruent to triangle A?

..... and .....  
**(2)**

91. Work out

$$1\frac{1}{3} \times 2\frac{2}{5}$$

Give your answer as a mixed number.

.....  
**(3)**

92. Work out

$$\frac{5}{13} \div \frac{2}{3}$$

.....  
**(1)**

---

93. Write down the reciprocal of 0.35

.....  
**(1)**

---

94. Work out the difference between  $-3^{\circ}\text{C}$  and  $4^{\circ}\text{C}$

..... $^{\circ}\text{C}$   
**(1)**

At 5am the temperature is  $-6^{\circ}\text{C}$

By 2pm the temperature went up by  $9^{\circ}\text{C}$

From 2pm to 11pm the temperature went down by  $15^{\circ}\text{C}$

(b) Work out the temperature at 11pm

..... $^{\circ}\text{C}$   
**(2)**

---

95. Here are four digits.

9    4    7    5

(a) Use two of these digits to make the largest possible two-digit number.

.....  
**(1)**

(b) Use all four of these digits to make the four-digit number closest to 5000.

.....  
**(1)**

96. The number of months,  $m$ , to complete a piece of research is found by  $m = \frac{600}{n}$

where  $n$  is the number of scientists working on the research.

How long should the research take if 12 scientists are working on it?

.....  
(2)

---

97. Sophie asks 20 of her friends to choose their favourite sport.

Their replies are

Rugby      Football      Rugby      Hockey      Cricket  
Football      Football      Rugby      Hockey      Football  
Rugby      Cricket      Hockey      Football      Football  
Football      Rugby      Football      Football      Rugby

Complete the tally and the frequency columns in the table below.

Sport	Tally	Frequency
Rugby		
Football		
Hockey		
Cricket		

(2)

98. Below is a line graph that shows the population of a village.

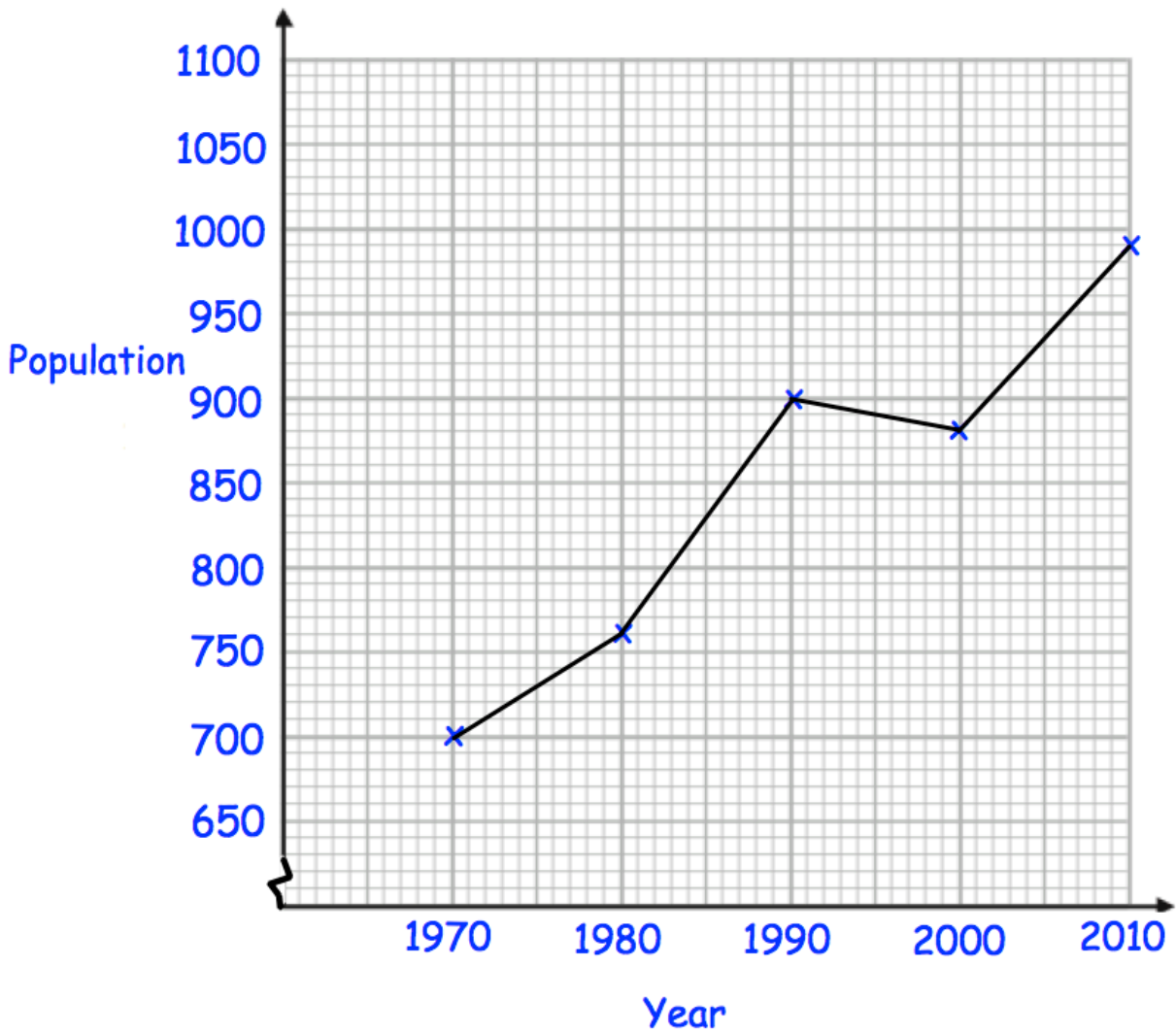

(a) What was the population in 1980?

.....  
(1)

(b) In which year was the population 700?

.....  
(1)

The population increased by 120 by 2020.

(c) Work out the population in 2020.

.....  
(2)

99. A rugby team can win, draw or lose a match.  
The table shows the probabilities of each result.

Result	Win	Draw	Lose
Probability	0.4	0.35	

- (a) Calculate the missing probability in the table.

.....  
(2)

Each win is worth 2 points.  
Each draw is worth 1 point.  
Each loss is worth 0 points.  
The rugby team plays 20 games in a season.

- (b) Work out how many points the rugby team should receive in one season.

.....  
(3)

100. A three-sided spinner is labelled A, B and C.

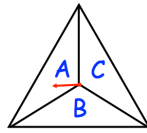

The spinner is spun and the frequency the letter A is recorded every 10 spins. The table below shows this information.

Spins	10	20	30	40
Frequency of an A	5	12	21	26

(a) Complete plot the relative frequencies on the graph below.

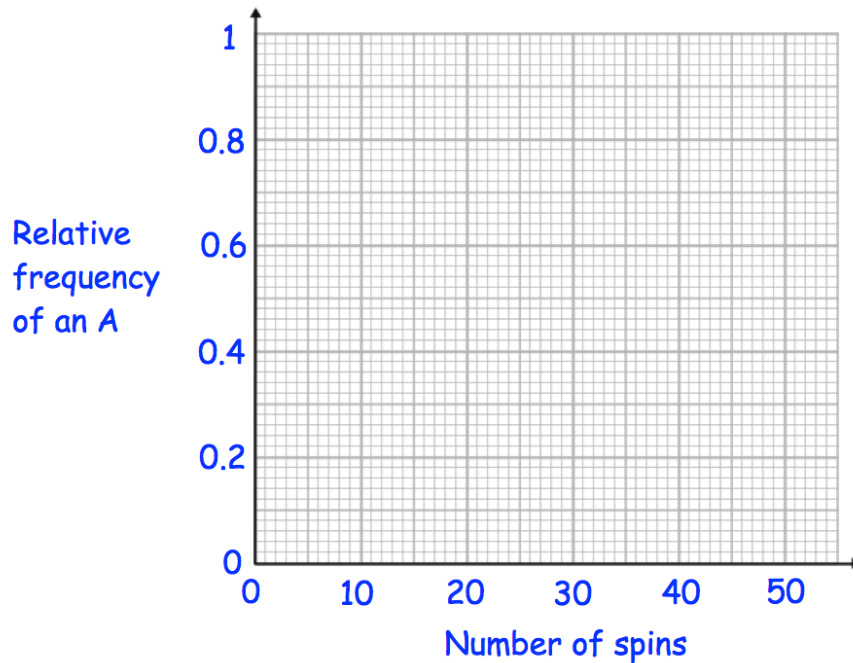

(3)

(b) Neil says the relative frequency after 50 spins is 0.8  
Explain why Neil must be wrong

.....

.....

(2)

101.

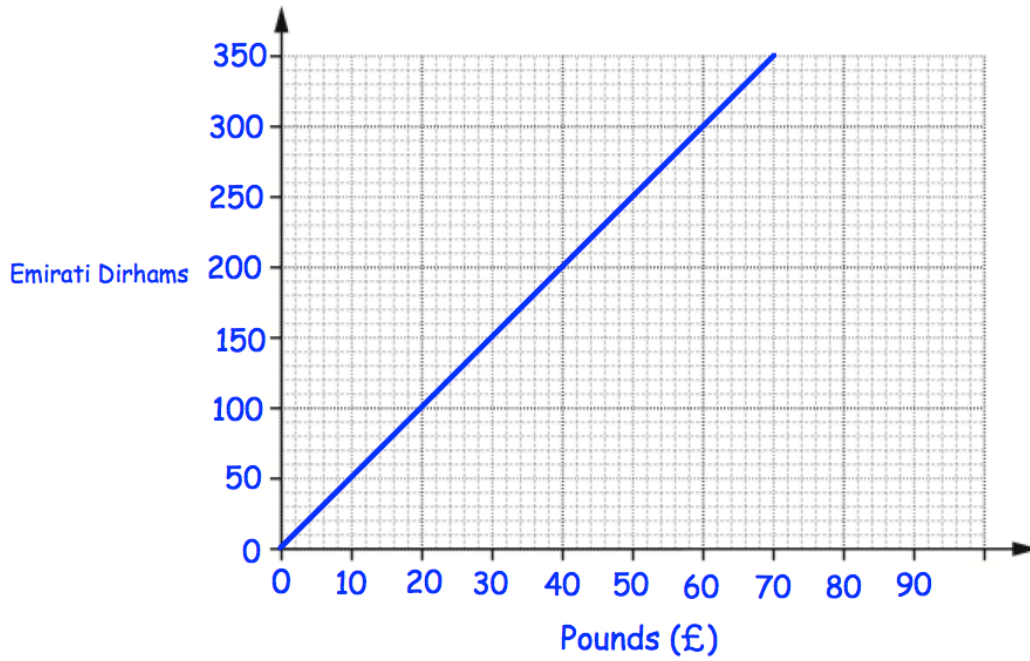

Tom wants to buy a camera.  
In London the camera costs £380.  
In Abu Dhabi the camera costs 2000 Dirhams.

In which city is the camera cheaper and by how much?  
Give your answer in pounds.

City:..... £.....

(1)

102. (a) Complete the table of values for  $y = x^3 - 2x + 3$

$x$	-2	-1	0	1	2
$y$					

(2)

(b) On the grid, draw the graph of  $y = x^3 - 2x + 3$  for the values of  $x$   $-2 \leq x \leq 2$

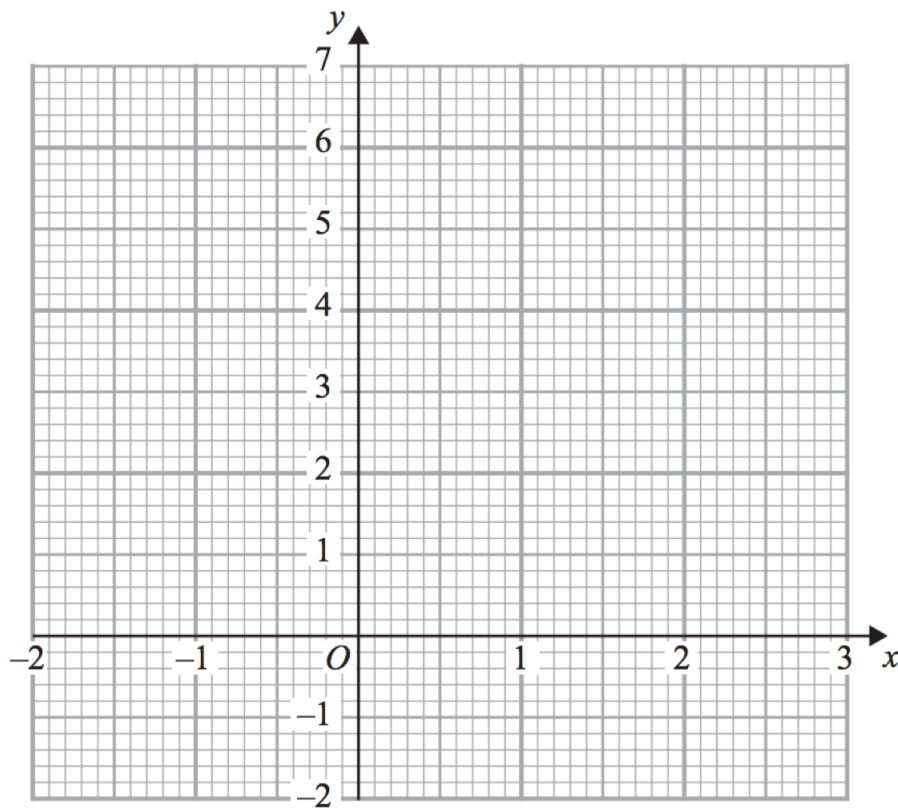

(2)

103. (a) Complete the table of value for  $y = \frac{4}{x}$

$x$	0.5	1	2	4	8	10
$y$						

(2)

(b) On the grid, draw the graph of  $y = \frac{4}{x}$  for  $0.5 \leq x \leq 10$

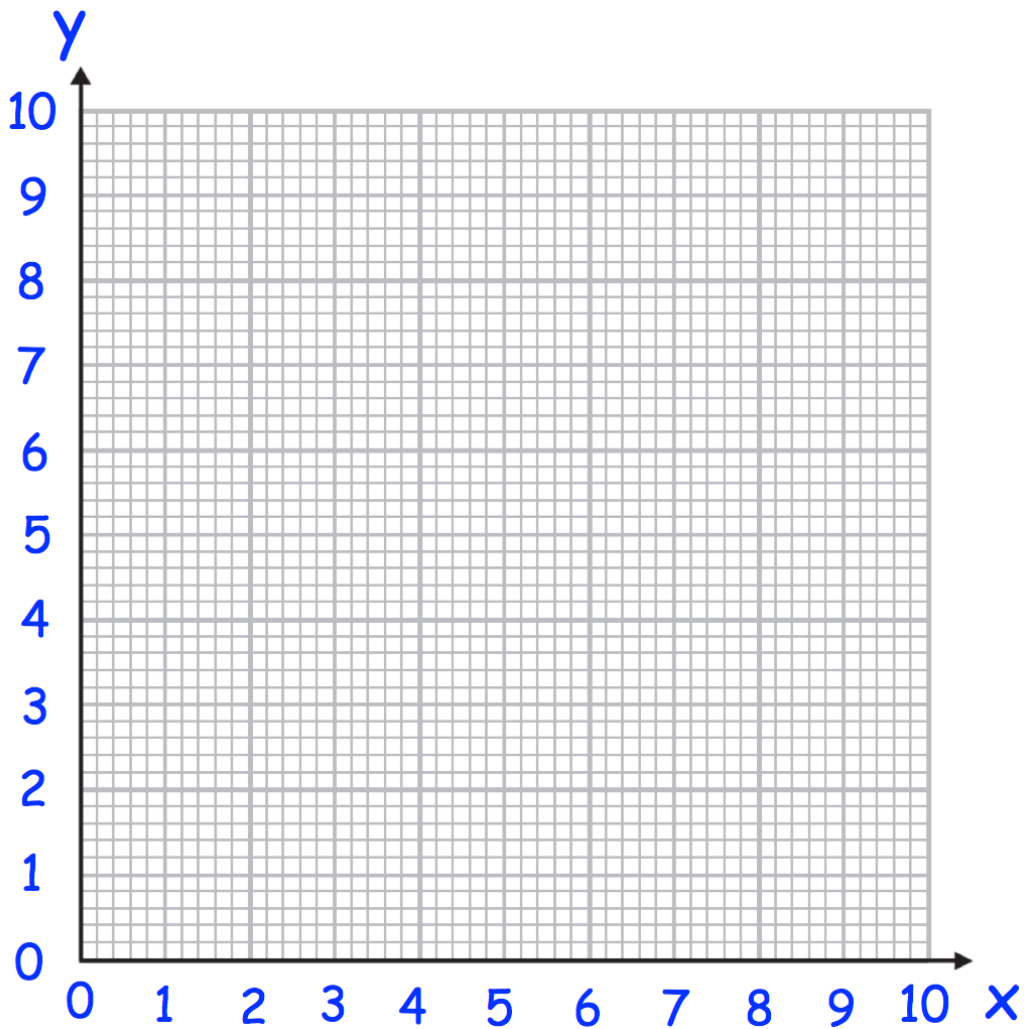

(2)

104. Shown below is a right-angled triangle.

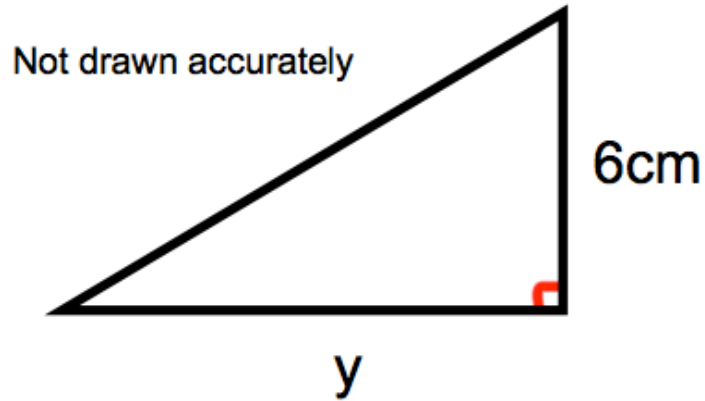

The area of the triangle is  $21\text{cm}^2$   
Calculate  $y$ , the length of the base.

.....cm  
(2)

---

105.

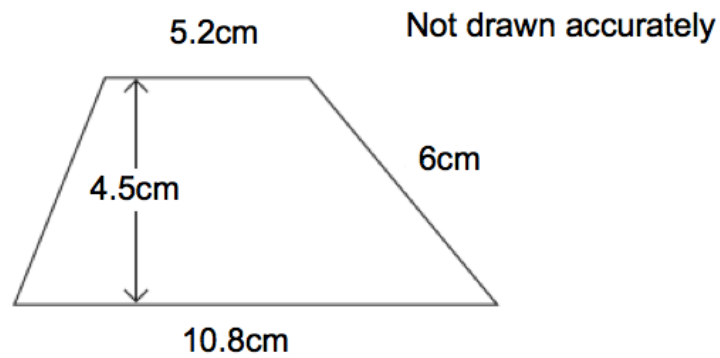

Calculate the area of the trapezium.

..... $\text{cm}^2$   
(2)

106.

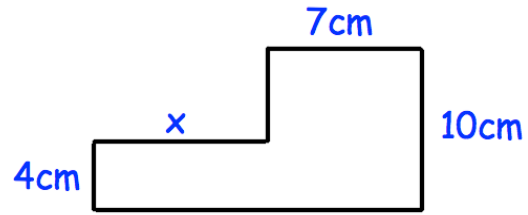

The area of the compound shape is  $106\text{cm}^2$ .  
Work out the size of  $x$ .

.....cm  
(3)

107. The diagram shows two lighthouses.

A boat is within than 8 miles of lighthouse A.

The same boat is within 6 miles of lighthouse B.

Shade the possible area in which the boat could be.



(2)

108. The distance from Leek to Milton is 310 miles.  
A train travels this distance in 4 hours 15 minutes.

Calculate the average speed of the train.

.....mph  
**(3)**

---

109. Bethany drove to a family meal and then back home.  
The meal was at a restaurant that is 70 kilometres from her home.

Bethany left home at 10:00 and arrived at the restaurant at 11:30.  
She stayed at the family meal for 2 hours.  
Bethany then drove home at a speed of 35 kilometres per hour.

Show this information on the distance-time graph.

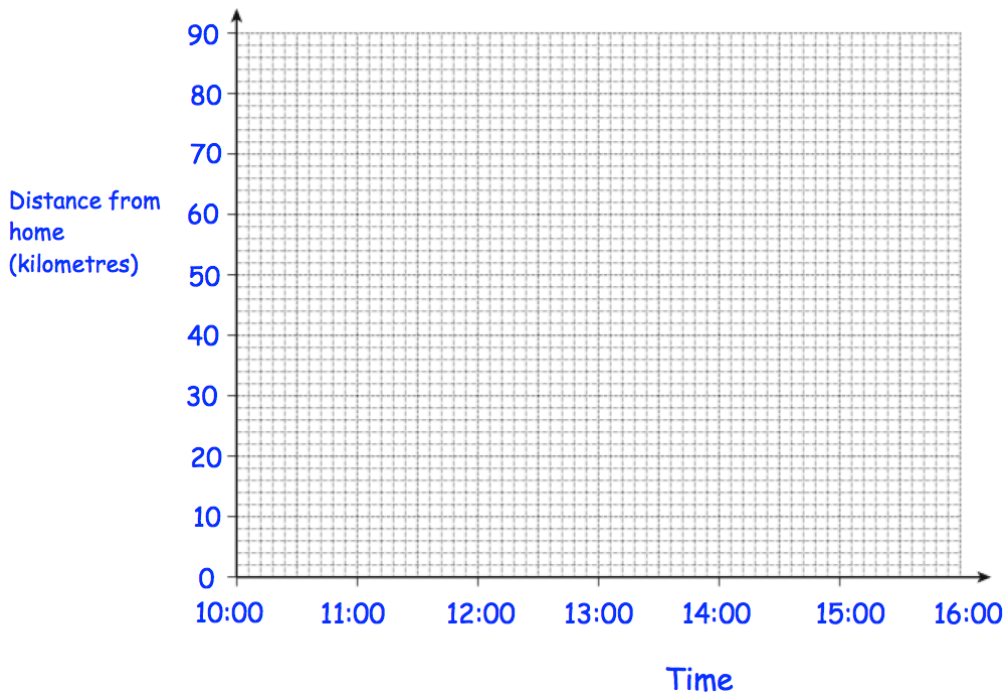

**(3)**

110. Shown below is a trapezoid prism.

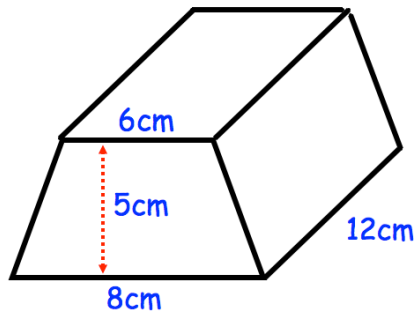

Find the volume of the prism.

.....cm<sup>3</sup>  
(4)

111. Megan says “when you square root a number, the answer is always smaller.”

Show she is wrong.

(2)

112. Shown below are five cards which are arranged in order from smallest to largest

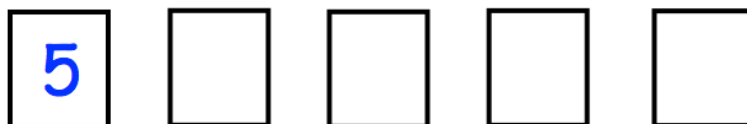

The range of the cards is 4.  
The median of the cards is 8.  
The mean of the cards is 7.

Work out the 4 missing numbers.

....., ....., ..... and .....  
(4)

113. 480 students attend a school.  
 A teacher asks 50 students which colour they would like the new school blazer to be.  
 The table shows the results.

Colour	Number of students
Black	20
Navy	15
Green	9
Maroon	6

Estimate how many of the 480 students would like a black blazer.

.....  
 (2)

114. Here is a pattern of dots



- (a) Continue the pattern to show Pattern 4

(2)

- (b) How many dots will there be in Pattern 6?

.....  
 (1)

115. Factorise

$$15y + 20$$

.....  
(2)

---

116. (a) Factorise  $x^2 + 2x - 24$

.....  
(2)

(b) Factorise  $x^2 - 25$

.....  
(1)

117. The graph below shows the depth of water in a container.

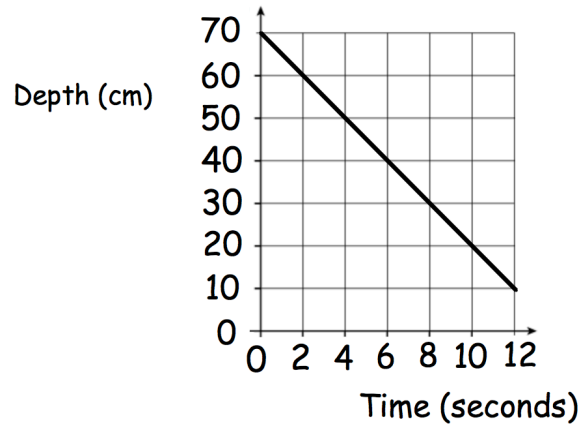

(a) Write down the gradient of the line

.....  
(1)

(b) What does the gradient of the line represent?

.....  
(1)

---

118.  $y = w - 2a^2$

$w = 400$

$a = 5$

Work out the value of  $y$ .

.....  
(2)

119. Here is part of a timetable for a bus.

Southville	09 18	10 38	12 05
Leek	09 28	10 48	-----
Milton	09 41	11 01	-----
Newtown	09 49	11 09	-----
Red Island	09 55	11 15	12 36
Sandville	10 13	11 33	-----
Bakerstown	10 31	11 51	13 00

A bus leaves Southville at 10 38

(a) At what time should the bus arrive at Newtown?

.....  
(1)

(b) How long will the journey take?

.....minutes  
(1)

James arrives at the Milton bus stop at 09 29.  
He waits for the next bus to Red Island.

(c) (i) How many minutes should he wait?

.....minutes  
(1)

(ii) At what time should James arrive at Red Island?

.....  
(1)

Sally wants to travel from Southville to Bakerstown.  
The 12 05 is an 'express' bus.

(d) How many minutes shorter is the journey if she takes the 'express bus'?

.....minutes  
(2)

120. Below is a solid shape.

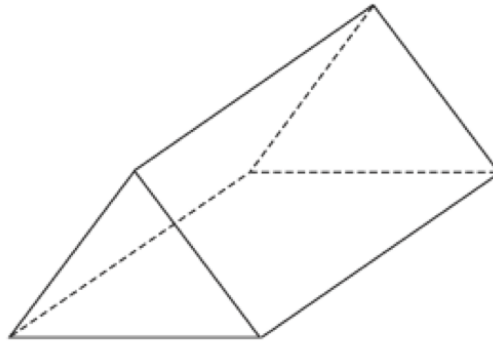

(a) What is the mathematical name for the shape?

.....  
**(1)**

(b) Write down the number of vertices

.....  
**(1)**

(c) Write down the number of faces

.....  
**(1)**

(d) Write down the number of edges

.....  
**(1)**

121. The diagram shows a scale drawing.

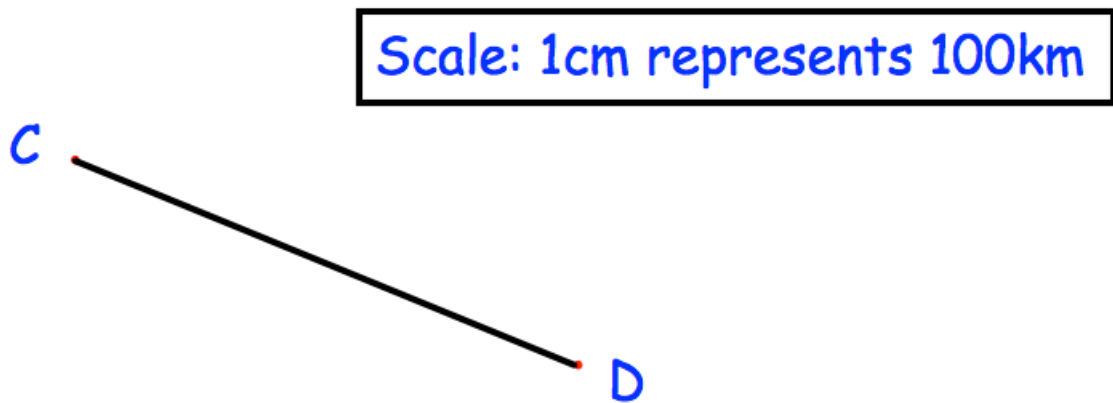

(a) Use the diagram to calculate the actual distance from C to D.

.....km  
(2)

E is 300km due south of C.

(c) Show E on the diagram.

(1)

122. Hannah is baking two cakes.

One cake needs  $1\frac{1}{3}$  cups of milk.

Hannah has  $1\frac{1}{4}$  cups of milk.

How much more milk does Hannah need?

.....cups  
**(3)**

---

123.

Name	Price (£)	Mass (kg)	Thickness (cm)	Battery (minutes)
Epic	£799	1.23	1.89	690
Bell	£1249	1.2	1.52	650
Lemon	£1599	1.37	1.49	720
HB	£799	1.28	1.7	740
Lazer	£1049	1.35	1.66	660

(a) Which laptop is the thickest?

.....  
**(1)**

(b) How much longer does the HB battery last than the Bell battery?

.....  
**(1)**

124. A is the point with coordinates (1, 4).  
B is the point with coordinates (7, 22).

Find the gradient of AB.

.....  
**(2)**